

ENOCH CITY ENGINEERING STANDARDS

April 2023

[Abstract](#)

[Draw your reader in with an engaging abstract. It is typically a short summary of the document.
When you're ready to add your content, just click here and start typing.]

FORWARD

The Enoch City Staff and City Engineer has prepared the following edition of the

ENOCH CITY ENGINEERING STANDARDS

These standards shall be used for all work located within public streets, rights-of-way, and easements within Enoch City.

Nothing in these standards shall be construed to prohibit the construction of higher type improvements, as approved by the City Engineer.

These Standards meet with the full approval of the Enoch City Staff and City Engineer, dated _____.

These Standards were approved by the City Council of Enoch City by Resolution dated _____, with revisions approved as follows:

TABLE OF CONTENTS

GENERAL IMPROVEMENT REQUIREMENTS

2.1	GENERAL.....	1
2.2	DEFINITIONS.....	2-1
2.3	CONSTRUCTION DRAWINGS	2-2
	2.3.1 GENERAL.....	2-2
	2.3.2 TITLE SHEET	2-3
	2.3.3 IMPROVEMENT PLAN SHEET	2-3
	2.3.4 PLAN PROFILE SHEETS	2-4
	2.3.5 DETAIL SHEETS	2-4
	2.3.6 MISCELLANEOUS DRAWING SHEETS	2-5
2.4	INSPECTIONS, TESTING AND QUALITY CONTROL.....	2-5
	2.4.1 REQUESTS FOR INSPECTION	2-5
	2.4.2 CONSTRUCTION COMPLETION INSPECTION.....	2-5
	2.4.3 QUALITY CONTROL TESTING	2-5
	2.4.4 TEST REPORTS	2-5
2.5	AS-BUILT DRAWINGS.....	2-6
2.6	GUARANTEE OF WORK.....	2-6
2.7	BARRICADES AND WARNING SIGNS.....	2-7
2.8	SURVEY MONUMENTS.....	2-7
2.9	IMPROVEMENT SEQUENCE	2-7

SECTION 3 DESIGN STANDARDS

3.1	GENERAL.....	3-1
3.2	STREET DESIGN	3-1
	3.2.1 GEOMETRIC DESIGN.....	3-2
	3.2.2 INTERSECTIONS.....	3-2
	3.2.3 CUL-DE-SACS.....	3-2
	3.2.4 STREET ACCESS.....	3-2
	3.2.5 CURB SIDE MAIL BOXES	3-3
	3.2.6 SIGNS	3-3
	3.2.7 TEMPORARY STREETS	3-3
	3.2.8 ACCESS CONTROL.....	3-3
	3.2.9 ASPHALT TAPERS.....	3-3
3.3	DRAINAGE SYSTEM DESIGN	3-3
	3.3.1 SPRING CONTROL	3-3
	3.3.2 FLOOD CONTROL	3-3
	3.3.3 CURB & GUTTER.....	3-4
	3.3.4 MINIMUM PIPE SIZE.....	3-4

	3.3.5	MINIMUM PIPE SLOPE.....	3-4
	3.3.6	STORM DRAIN MANHOLES.....	3-5
3.4		SANITARY SEWER DESIGN	3-5
	3.4.1	DESIGN FLOWS	3-5
	3.4.2	MINIMUM SIZE AND DEPTH	3-6
	3.4.3	ALIGNMENT.....	3-6
	3.4.4	SERVICE CONNECTIONS.....	3-7
	3.4.5	SEWER MANHOLES & GREASE TRAPS WITH SAMPLING MANHOLES.....	3-8
	3.4.6	SEWER LIFT STATIONS	3-8
	3.4.7	GREASE, OIL & SAND INTERCEPTOR WITH SAMPLING MANHOLE ...	3-9
3.5		CULINARY WATER DESIGN	3-10
	3.5.1	DESIGN FLOW PRESSURE.....	3-10
	3.5.2	PEAK INSTANTANEOUS FLOW	3-10
	3.5.3	MINIMUM SIZE AND DEPTH	3-10
	3.5.4	VALVES AND HYDRANTS	3-11
	3.5.5	PRESSURE REDUCING VALVES	3-11
	3.5.6	FIRE HYDRANT SPACING AND LOCATION	3-11
	3.5.7	FIRE FLOW REQUIREMENTS.....	3-12
	3.5.8	MISCELLANEOUS WATER SYSTEM DESIGN CRITERIA	3-12
3.6		OTHER UTILITIES SYSTEMS DESIGN.....	3-13
	3.6.1	RESPONSIBILITY	3-13
	3.6.2	STREETS LIGHTS	3-13
	3.6.3	BURIAL OF LINES	3-13
	3.6.4	LAYOUT	3-13
	3.6.5	FRONT LOT LINE SYSTEMS.....	3-13
	3.6.6	QUALITY CONTROL.....	3-13

**SECTION 4
CONSTRUCTION STANDARDS**

4.1		EARTHWORK.....	4-1
	4.1.1	DEFINITIONS	4-1
		I. EMBANKMENT.....	4-1
		II. FILL	4-1
		III. BACKFILL.....	4-1
		IV. SUBGRADE.....	4-1
		V. MAXIMUM DRY DENSITY	4-1
	4.1.2	MATERIALS.....	4-1
		I. EXCAVATION	4-1
		II. COARSE GRAVEL.....	4-1
		III. BACKFILLS	4-2
	4.1.3	CONSTRUCTION METHODS	4-2
		I. CONSTRUCTION OF EMBANKMENTS.....	4-2
		II. COMPACTION OF EARTH MATERIALS.....	4-2
		III. SUBGRADE PREPARATION	4-3
		IV. CONSTRUCTION OF NON-STRUCTURAL FILLS.....	4-4
	4.1.4	QUALITY CONTROL.....	4-4

	I.	TESTING.....	4-4
	II.	ACCEPTANCE	4-4
4.1.5		SPECIAL EARTH WORK REQUIREMENTS	4-5
4.2		PIPELINE CONSTRUCTION	4-5
4.2.1		MATERIALS.....	4-5
	I.	SEWER PIPE.....	4-5
	II.	STORM DRAIN PIPES.....	4-7
	III.	SEWER MANHOLES.....	4-7
	IV.	WATER PIPE AND FITTINGS.....	4-9
	V.	FLOWABLE BACKFILL	4-19
	VI.	PIPELINE CASINGS	4-20
4.2.2		CONSTRUCTION METHODS	4-21
	I.	CONTROL OF GROUND WATER	4-21
	II.	EXCAVATION FOR PIPELINES	4-21
	III.	SHEETING, BRACING AND SHORING OF EXCAVATIONS	4-22
	IV.	BLASTING.....	4-22
	V.	PIPE LAYING AND BEDDING	4-23
	VI.	BACKFILLING AND COMPACTION.....	4-27
	VII.	TRENCHES ON HIGHWAYS AND STREETS.....	4-29
	VIII.	CLEANING OF SANITARY SEWER LINES.....	4-30
	IX.	CLEANING AND DISINFECTION OF WATER SYSTEMS.....	4-30
4.2.3		QUALITY CONTROL.....	4-31
	I.	TRENCH BACKFILL MOISTURE/DENSITY TESTING.....	4-31
	II.	SANITARY SEWER LINE TEST AND ACCEPTANCE	4-32
	III.	WATER SYSTEM TESTING AND ACCEPTANCE.....	4-35
4.3		ROADWAY CONSTRUCTION.....	4-36
4.3.1		MATERIALS.....	4-37
	I.	BASE COURSE MATERIAL.....	4-37
	II.	BITUMINOUS PRIME COAT MATERIAL.....	4-39
	III.	BITUMINOUS SURFACE COURSE MATERIAL	4-39
	IV.	BITUMINOUS SEAL COAT MATERIAL (ASPHALT EMULSION/FLUSH COAT).....	4-40
	V.	BITUMINOUS SEAL COAT MATERIALS (CHIP SEAL).....	4-42
	VI.	STREET SIGN MATERIALS.....	4-43
4.3.2		CONSTRUCTION METHODS AND EQUIPMENT.....	4-44
	I.	PIT RUN CONSTRUCTION METHODS AND EQUIPMENT	4-44
	II.	ROAD BASE CONSTRUCTION METHODS AND EQUIPMENT	4-45
	III.	BITUMINOUS PRIME COAT CONSTRUCTION METHODS	4-45
	IV.	BITUMINOUS SURFACE COURSE CONSTRUCTION METHODS AND EQUIPMENT	4-47
	V.	BITUMINOUS FLUSH COAT CONSTRUCTION METHODS.....	4-48
	VI.	BITUMINOUS CHIP SEAL CONSTRUCTION METHODS	4-49
	VII.	STREET SIGN INSTALLATION METHODS	4-51
4.3.3		QUALITY CONTROL.....	4-51
	I.	BASE COURSE QUALITY CONTROL.....	4-51
	II.	BITUMINOUS SURFACE COURSE - QUALITY CONTROL.....	4-52

	III.	BITUMINOUS FLUSH COAT QUALITY CONTROL	4-53	
	IV.	BITUMINOUS CHIP SEAL COAT QUALITY CONTROL.....	4-54	
4.4		CONCRETE WORK	4-54	
	4.4.1	MATERIALS.....	4-54	
		I.	PORTLAND CEMENT CONCRETE MATERIAL	4-54
		II.	CONCRETE REINFORCING MATERIALS.....	4-59
		III.	CONCRETE BASE MATERIALS	4-60
	4.4.2	CONSTRUCTION METHODS AND EQUIPMENT.....	4-60	
		I.	GENERAL CONCRETE PLACEMENT.....	4-60
		II.	CONCRETE REINFORCEMENT INSTALLATION.....	4-63
		III.	CURB & GUTTER CONCRETE PLACEMENT.....	4-64
		IV.	CONCRETE BASE MATERIALS PLACEMENT	4-66
	4.4.3.	QUALITY CONTROL.....	4-67	
		I.	CONCRETE TESTING.....	4-67
		II.	CONCRETE BASE MATERIALS TESTING.....	4-67
		III.	ACCEPTANCE	4-68
4.5		STREET LIGHTS.....	4-71	
	4.5.1	MATERIALS.....	4-71	
		I.	LUMINARIES MATERIALS	4-71
		II.	POLE MATERIALS.....	4-73
	4.5.2	CONSTRUCTION METHODS AND EQUIPMENT.....	4-74	
		I.	ASSEMBLY	4-74
		II.	MOUNTING.....	4-74
		III.	ELECTRICAL CONNECTIONS.....	4-74
		IV	LOCATION AND SPACING	4-74
		STANDARD DETAILS	4-73	

LIST OF TABLES

TABLE 3.1	STREET DESIGN STANDARDS	3-1
TABLE 3.2	SANITARY SEWER DESIGN FLOWS.....	3-5
TABLE 3.3	SANITARY SEWER MINIMUM SLOPES	3-6
TABLE 3.4	SANITARY SEWER LATERALS	3-7
TABLE 4.1	DUCTILE IRON PIPE TOLERANCE.....	4-11
TABLE 4.2	BACKFILL MATERIALS	4-22
TABLE 4.3	ROAD CROSS-SECTION STANDARDS	4-37
TABLE 4.4	PIT RUN GRADATION	4-38
TABLE 4.5	TYPE II (ROAD BASE) GRADATION.....	4-39
TABLE 4.6	BITUMINOUS SURFACE COURSE AGGREGATE GRADATION	4-40
TABLE 4.7	ASPHALT EMULSION TEST SPECIFICATIONS	4-41
TABLE 4.8	GRADATION OF AGGREGATE FOR CHIP SEAL COATS	4-43
TABLE 4.9	BITUMINOUS SURFACE COURSE SPECIFICATION	4-47
TABLE 4.10	CONCRETE MIX SPECIFICATIONS.....	4-58
TABLE 4.11	REINFORCING BAR CLEARANCE	4-64
TABLE 4.12	STREET LIGHT FIXTURES.....	4-72
TABLE 4.13	STREET LIGHT POLES.....	4-74

SECTION 5
STANDARD DETAILS

CONCRETE DETAILS

CURB AND GUTTER	C-1.1
ROLL CURB & GUTTER.....	C-1.2
6'-0" CROSS GUTTER	C-2.0
DRIVEWAYS.....	C-3.0
TYPICAL DRIVEWAY BREAK	C-4.0
ACCESSIBLE RAMP	C-5.0
CONCRETE SIDEWALK.....	C-6.0
CONCRETE PAD FOR MAILBOX	C-7.0
FALSE RADIUS	C-8.0

ROAD/STREET DETAILS

EARTH FILLED TRENCH SECTION	R-1.1A&B
SLURRY FILLED TRENCH SECTION	R-1.2
UTILITY LOCATION	R-2.0
TYPICAL 50'0" ROAD SECTION	R-3.1
TYPICAL 66'0" & 100'0" ROAD SECTIONS.....	R-3.2
SPECIAL ROAD SECTIONS	R-3.3
PLANTER STRIP ROAD SECTIONS	R-3.4
RESIDENTIAL ESTATE ROAD SECTION	R-3.5
TYPICAL 50.0" INDUSTRIAL ROAD SECTION.....	R-3.6
TYPICAL CUL-DE-SAC	R-4.0
TYPICAL KNUCKLE FOR 50'0" WIDE STREET	R-5.0
CENTERLINE MONUMENT	R-6.0
INDIVIDUAL MAILBOX	R-7.0
STREET SIGN	R-8.0A&B
ASPHALT TAPER.....	R-9.0
TYPICAL CONDUIT CROSSING	R-10.0A&B
PUD ACCESS TURN AROUND	R-11.0A&B
LOCAL STREET LIGHT.....	R-12.1
COMMERCIAL STREET LIGHT.....	R-12.2A&B
INDUSTRIAL STREET LIGHT.....	R-12.3A&B
SIDEWALK AT EROSION CONTROL WALL.....	R-13
STREET/TRAIL CROSSING	R-14.1
TRAIL SIGN FACE	R-14.2
ANGLE PARKING STALL PAVEMENT MARKING.....	R-15.0
CENTER LANDSCAPED MEDIAN.....	R-16.0
MEDIAN INTERSECTION W/CORNER ACCESS RAMP	R-17.1
MEDIAN INTERSECTION W/STREET ACCESS RAMP.....	R-17.2
BULB ROAD.....	R-18.0
66' & 100' R.O.W. LEFT TURN MEDIAN	R-19.0

SEWER DETAILS

SEWER LATERAL.....	S-1.0A&B
--------------------	----------

NEW SEWER MANHOLE & EXISTING CONNECTION	S-2.0A&B
DROP MANHOLE	S-3.0
GREASE, OIL & SAND INTERCEPTOR & SAMPLING MANHOLE FOR SANITARY SEWER.....	S-4.0
SELF PRIMING SEWER LIFT STATON.....	S-5.0A-D
SEWER LIFT STATION SITE PLAN.....	S-6.0
PRESSURE SEWER CLEAN OUT, LATERAL & LOCATOR POST.....	S-7.0
SEWER LIFT STATION MANHOLE	S-8.0
TEMPORARY SEWER MAIN CLEAN-OUT (UNPAVED AREA).....	S-9.1
TEMPORARY SEWER MAIN CLEAN-OUT (PAVED AREA).....	S-9.2
RV DUMP STATION DETAIL.....	S-10.0

DRAINAGE DETAILS

CURB INLET BOX	D-1.0
LARGE CURB OUTLET BOX	D-2.0
SMALL CURB OUTLET BOX.....	D-3.0
STORM DRAIN, CULVERT & END SECTIONS	D-4.0
STORM DRAIN MANHOLE	D-5.0A&B
DETENTION BASIN	D-6.0A&B
IRRIGATION DIVERSION BOX.....	D-7.0
SMALL IRRIGATION CULVERT INLET BOX.....	D-8.0
BORROW DITCH DRIVEWAY ACCESS.....	D-9.0

TESTING REQUIREMENTS

MINIMUM TESTING REQUIREMENTS.....	T-1.0
-----------------------------------	-------

WATER DETAILS

WATER VALVE BOX AND COLLAR	W-1.1
WATER VALVE EXTENSION & BLOW-OFF.....	W-1.2
FIRE HYDRANT	W-2.0
THRUST BLOCKS	W-3.0
6" PRESSURE REDUCING VALVE W/ 2" BYPASS	W-4.0A&B
1" WATER METER	W-5.1A&B
1 1/2" WATER METER	W-5.2A&B
2" WATER METER.....	W-5.3A&B
3" - 4" WATER METER	W-5.4A&B
WATER METER WITH FIRE FLOW	W-6.0A&B
FIRE LOOP DETECTOR CHECK VALVE	W-7.0A&B
IRRIGATION METER.....	W-8.0A&B
WATER MAIN TO MAIN CONNECTION	W-9.0
COMBINATION AIR VALVE OUTSIDE ROADWAY.....	W-10.1
COMBINATION AIR VALVE IN ROADWAY.....	W-10.2
WATER SAMPLING STATION.....	W-11.0

MISCELLANEOUS DETAILS

TYPICAL SUBDIVISION PLATX-1
TYPICAL P.U.D. PLAT.....X-2
TESTING SCHEDULEX-3

SECTION 2 GENERAL IMPROVEMENT REQUIREMENTS

2.1 GENERAL: This section defines the general requirements for public improvements within Enoch City.

The improvements shall include all improvements of a public need, including, but not limited to streets, water, sewer, and drainage. Required improvements shall extend from the nearest acceptable point of existing improvements. Layout must provide for future extension to adjacent properties and shall be compatible with appropriate City master plans. All water & sewer lines shall be installed to the boundary lines of the development, unless approved by the City. Required geotechnical investigation recommendations shall be followed.

2.2 DEFINITIONS:

2.2.1 CONTRACTOR shall refer to the person or persons whom are actually performing the construction work and whom hold the proper licenses from the State of Utah.

2.2.2 CUSTOMER shall refer to any individual requiring utility services (power, water or sewer).

2.2.3 DEVELOPER shall refer to the contractor, property owner or agent as applicable.

2.2.4 CITY ENGINEER shall refer to the Enoch City Engineer or an authorized representative.

2.2.5 OWNER shall refer to subdividers, developers, or others responsible for constructing improvements or developments on property within Enoch City.

2.2.6 SEWER LATERAL shall refer to any sanitary sewer pipe which runs from the outside of any building to the sewer main line.

2.2.7 SEWER MAIN shall refer to any sanitary sewer line that is eight-inches in diameter or greater which are owned and maintained by Enoch City.

2.2.8 SEWER OUTFALL LINE shall refer to any sanitary sewer line that is greater than 12" diameter and carries major sectors of the community or region having trunk lines as its tributaries.

2.2.9 WATER LATERAL shall refer to any domestic service water pipe, including meter box or vault, meter setter, valving and lid.

2.2.10 WATER DISTRIBUTION MAIN shall refer to any domestic water line that is 6-inch to 12-inch in diameter which distributes culinary water to the customer.

2.2.11 WATER TRANSMISSION MAIN shall refer to any domestic water line that is larger than 12-inches in diameter.

2.3 CONSTRUCTION DRAWINGS: Complete and detailed construction plans and drawings of improvements shall be submitted to the City Engineer. No construction shall be started until plans have been checked and approved by the City Engineer, and other appropriate City officials.

The following instructions are for the purpose of standardizing the preparation of drawings to obtain uniformity in appearance, clarity, size and style:

One (1) set of construction plans shall be submitted to the City Engineer for checking and returned to the Owner/Contractor for correction. When all corrections have been made and the set approved, one (1) electronic copy and one (1) wet-stamped hardcopy of the approved set shall be provided to the City.

The plans and designs shall meet the standards defined in the Specifications and Drawings hereinafter outlined.

All drawings and/or prints shall be clear and legible and conform to good engineering and professional drafting room practice. Generally, the size of drawings shall be 24"x36".

The developer shall also provide all as-built drawings in an electronic format designated by the City Engineer or other appropriate City official.

2.3.1 GENERAL: The following shall be included on all drawings:

- I. North arrow.
- II. Scale (1" = 100' Minimum).
- III. Consistent letter, stationing and numbering that reads left to right on the page and does not overlap with other text or leaders.
- IV. Title block, located along the right side of each sheet to include:
 - A. Project title;
 - B. Date drawn;
 - C. Engineer/Surveying Company Name, Address, Phone # and Fax #;
 - D. Professional Engineers stamp box (licensed in the State of Utah) with Signature and Date;
 - E. Internal checker's initials box;

- F. The section, township and range location of the project;
- G. Sheet number box.
- V. All drawing features on that drawing shall be labeled using a tag and construction note format.
- VI. All required coordinates on that drawing shall be shown using a tag and table format, using a unique tag # for each different kind of feature- i.e. S.M.H. #1, GV #1 for Sewer Manhole and Gate Valves respectively.
- VII. All coordinates shown on the construction drawings shall be based upon the Cedar City Coordinate System.

2.3.2 TITLE SHEET THAT INCLUDES:

- I. Project Name
- II. Vicinity Map
- III. Project Concept Plan
- IV. Drawing Index
- V. Public Works Approval Certificate
- VI. City Engineers Approval Certificate
- VII. Utility Contacts Per Checklist

2.3.3 AN OVERALL IMPROVEMENT PLAN SHEET OR PRELIMINARY SUBDIVISION PLAN that includes the following and other information as required by the checklist:

- I. Survey control monument locations including sectional tie bearing and lengths, basis of bearing and elevation datum – NAVD 27.
- II. Street layout including name and or numbers, width and fillets.
- III. Water system layout including pipe size, valving, fire hydrants, PRV's and air vacs.
- IV. Sewer system layout including pipe size, and manholes.
- V. Drainage system layout including pipe size, manholes, curb inlets and

outlets, channels, detention basins and irrigation ditches.

VI. Street light layout.

2.3.4 PLAN/PROFILE SHEETS that include the following on the same plan/profile sheets and other information as required by the checklist:

- I. Proposed streets including master planned streets, names and/or numbers, curve data in tag and table format for each curve on the sheet, vertical curve information, existing street transitions, future street transitions, signs, slopes, centerline bearings and lengths, road stations and elevations on NAVD 27 datum, cul-de-sacs, street width, curb-gutter, sidewalk locations & elevations, handicap ramps, cross gutters, driveways, centerline monuments, asphalt tapers, conduit crossings, street lights, typical street cross sections from right-of-way line to right-of-way line, showing type of curb, sidewalk and pavement section.
- II. Proposed water lines including master planned water mains, sizes, material, valves, fire hydrants, blow-offs, PRV stations and water laterals.
- III. Proposed sewer lines, including master planned sewer lines, sizes, material, and slopes: manhole sizes, locations, elevation of rim and invert in and invert out; sewer lateral locations, sizes and material; pressure sewer lines and lift stations.
- IV. Proposed storm drain system including master planned storm drains, culverts, channels, size, slope, material; manhole sizes, locations, elevation on rim and inverts; curb inlets, curb outlets, end sections, detention basins and irrigation ditches.

2.3.5 DETAIL SHEETS: Each set of plans shall be accompanied by separate sheets of details that will be constructed on the project. Detail sheets shall include all current Enoch City Standard Engineering details that apply to the project plus and special details required for the project. A testing schedule will also be required on the detail sheets showing all required quality control tests in the format shown on the standard details

2.3.6 MISCELLANEOUS DRAWING SHEETS: The following miscellaneous drawing sheets shall be required if requested by the City Engineer:

- I. Finished street cross sections from 20' outside each right-of-way line shall be shown at intervals not exceeding 200 feet on all streets.
- II. A grading plan for the project showing finished pad and adjacent TBC elevations.

- III. A Storm Water Pollution Prevention Plan (SWPPP) showing the required BMPs for the site to control the storm water runoff.

2.4 INSPECTION, TESTING AND QUALITY CONTROL. All construction work involving the installation of improvements in Enoch City shall be subject to City inspection and testing as outlined in the quality control section of each specification.

2.4.1 REQUESTS FOR INSPECTION: Requests for inspections shall be made to the City Engineer or Inspector by the person responsible for the construction. Notice shall be given 24-hours in advance of the starting of work. Any work to be backfilled or covered shall not be backfilled or covered prior to inspection.

2.4.2 CONSTRUCTION COMPLETION INSPECTION. A final inspection shall be made by the City Engineer, or a representative upon receipt of a request by the owner after all construction work is completed. Any faulty or defective work shall be corrected by the persons responsible for the work, within a period of thirty (30) days from the date of the City Engineer's Inspection Report defining the faulty or defective work unless otherwise agreed upon with the City.

2.4.3 QUALITY CONTROL TESTING. Material testing shall be conducted by an independent laboratory, approved by the City Engineer, at the owner's expense. All testing shall comply with current ASTM, AASHTO, AWWA or Public Drinking Water Regulation standards and shall meet the minimum testing requirements as outlined in the specifications. Personnel performing tests shall have the appropriate certifications to perform such tests. The cost of any and all re-testing required to bring materials into specification shall be borne by the owner or contractor. The time and locations of all tests shall be approved by the City Engineer's office. If determined necessary by the City Engineer or a representative, additional testing can be required.

2.4.4 TEST REPORTS. Written test results will be required for review by the City Engineer after each portion of the work (i.e. pipeline construction, earthwork, curb, gutter and sidewalk, roadway construction).

A Final Grading Report submitted and stamped by a professional engineer registered in the State of Utah will be required from the developer's testing firm upon completion of the project. This report will include the following:

1. Title Sheet to include:
 - a. Project Name
 - b. Testing Company name, Address, Phone #, Fax #
 - c. Date
2. Certification letter signed/stamped, certifying all testing done per City Standards, materials with failed tests were corrected, opinion that project conforms to the City Standards as far as indicated by testing.
3. Testing summary – patterned after the testing schedule on the approved

Construction Drawings with additional columns for number of tests performed, number of tests passing, number of tests failing, comments.

4. Failed test/retest summary including:
 - a. Original Test ID#
 - b. Retest ID#
 - c. Improvement
 - d. Location
 - e. Retest results
5. All individual tests reports in the order of the testing schedule.

2.5 AS-BUILT DRAWINGS. Before final inspection, the developer shall provide a complete set of as-built drawings that includes all items specified in Section 2.3 Construction Drawings. The as-built drawings shall show all improvement dimensions as they were constructed in the field. The as-built drawings shall be submitted to the City Manager on 24” by 36” paper and in a .pdf format and in AutoCAD .dwg format. Two (2) copies of the hardcopy as-built plan sets are to be provided.

2.6 GUARANTEE OF WORK. The owner shall warrant and guarantee that the improvements provided for hereunder, and every part thereof, will remain in good condition for a period of one (1) year after the date of the acceptance of the project by the City. The owner shall make all repairs to and maintain the improvements and every part thereof in good condition during the specified time at no cost to the City.

The determination for the necessity of repairs and maintenance of the work shall rest with the City Engineer and City Public Works Director or Department Heads. Such decision upon the matter shall be final and binding upon the owner. The guarantee hereby stipulated shall extend to and include, but shall not be limited to, the entire road base, all pipes, joints, valves, manholes, backfill and compaction as well as the working surface, curbs, gutters, sidewalks, and other accessories that shall be constructed by the owner. Whenever, in the judgment of the City Engineer and Public Works Director, said work shall be in need of repairs, maintenance, or rebuilding, written notice shall be served upon the owner and thereupon the owner shall undertake and complete such repairs, maintenance or rebuilding. If the owner fails to do so within thirty (30) days from the date of the service of such notice, the City shall have such repairs made, and the cost of such repairs shall be paid by the owner together with 25 percent of the cost of the repairs in addition thereto, as stipulated damages for such failure on the part of the developer to make the repairs. Any omission on the part of the City to condemn defective work or material at the time of construction shall not be deemed an acceptance. The contractor and/or owner will be required to correct defective work or material at any time before final acceptance and within one (1) year thereafter.

2.7 BARRICADES AND WARNING SIGNS. The Contractor shall provide, erect, and maintain all necessary barricades, suitable and sufficient lights, danger signals, signs, and other traffic control devices. All necessary precautions shall be taken to protect the work and to safeguard the public. Streets closed to traffic shall be protected by effective barricades, and obstructions shall be illuminated during hours of darkness. Suitable warning signs shall be provided to control and direct traffic properly. All traffic control operations and signing shall be performed in accordance with the instructions outlined in the "Manual on Uniform Traffic Control Devices", latest edition. A

traffic control plan will be required for submittal and approval on each project.

2.8 SURVEY MONUMENTS. Standard City survey control monuments (as shown in the standard drawings of these standards) shall be installed in all streets to be dedicated for public use. All survey control monuments shall be installed in strategic locations (as determined by the City Engineer) so as to insure adequate survey control required for subsequent resurvey in the area.

2.9 IMPROVEMENT SEQUENCE. City improvements shall be installed in the following sequence, unless otherwise directed by the City Engineer.

1. Rough grading
2. Sanitary Sewer
3. Culinary Water
4. Storm Drain
5. Private Utilities & Conduits
(In Right-of-Way)
6. Sub Base
7. Curb and Gutter
8. Road Base
9. Asphalt
10. Private Utilities (In Easement)
11. Sidewalks
12. Manholes and Valve Grades
13. Survey Monument
14. Street Signs
15. Street Lights
16. Clean-up

(Private Utilities are Electric, Natural gas, Telephone and Cable T.V. Services)

Contractors and developers shall ensure that all improvement items previous to item #9 (asphalt) are installed before the asphalt. Prior to asphalt installation, developers will provide to the City Engineer a sign-off sheet signed by the electric, telephone, natural gas and cable T.V. utilities verifying their utility or appropriate conduits have been installed. The Development's Engineer and material testing firm shall also sign-off verifying all City required underground improvements (i.e. sewer, water, storm drains, etc.) have been installed and tested according to the approved Construction Drawings. **No road breaking permits will be issued on new City streets for two (2) years from the date the street was accepted by the City.**

SECTION 3 DESIGN STANDARDS

3.1 GENERAL. This section defines design requirements for public improvements within the City of Enoch City. It is not the intent of these standards to restrict professional judgment, but rather to serve as a guide and to establish consistency and the minimum requirements in design.

3.2 STREET DESIGN. All streets within Enoch City shall be designed structurally to conform to Section 4.3, "Roadway Construction", of these standards. Streets shall conform to City standards for location, grades, centerline curve radii, right-of-way, pavement, curb, gutter and sidewalk dimensions, and volumes as shown in Table 3.1.

**TABLE 3.1
STREET DESIGN STANDARDS**

STREET TYPE (Location)	DESIGN VOLUME/ Level of Service (Vehicles per day in each direction)	DESIGN TRAFFIC INDEX	MAX. GRADE (4)	MIN. C.L. RADIUS	MIN. INTER-SECTION RIGHT – OF – WAY RADIUS	RIGHT OF WAY Width (feet) (6)	PAVE-MENT Width (feet)	SIDE-WALK (1) (3) Width (feet)	CURB & GUTTER TYPE (2)
LOCAL	800/D	5.5	15	100	15	50	36	4	A
COLLECTOR	1600/C	5.5	12	200	15	66	51	4	A
MAJOR COLLECTOR (1/4 sec. line)	3200/C	6	12	300	20	66	51	4	A
ARTERIAL (Section line)	>3200/B	6.5	10	500	30	66	51	5	A
MAJOR ARTERIAL (Township/ Range lines)	-	7.5	10	600	35	100	81	6	A

Notes for Table 3.1:

(1) Streets shall not have a longitudinal grade of less than 0.5% unless adequate alternative street drainage is provided.

(2) Areas of high water flow may require larger curb and gutter capacity than shown.

(3) Sidewalk in areas of high pedestrian traffic shall require greater width as determined by the City.

(4) Road grades greater than 12% up to and including 15% shall be no longer than 100 feet. Grades greater than 10% up to and including 12% shall be no longer than 500 feet. Any road grade greater than 10% up to and including 15% shall have at least 200 feet of road length on each end with no grade greater than 10%.

(5) Required street widths to be determined by projected traffic volumes. Minimum street width will be 50-feet in residential areas and 50 feet in Commercial and Industrial areas.

(6) For right-of-way width for Road Section with Trails see Enoch Engineering Details.

3.2.1 GEOMETRIC DESIGN. Streets shall be designed to provide adequate stopping and sight distance, degree of curve, and super-elevation in accordance with The American Association of State Highway and Transportation Officials (AASHTO). Vertical curves shall be provided in all changes in grade where the algebraic difference is 1% or greater.

3.2.2 INTERSECTIONS. Street intersection centerline offsets shall be not less than 150 feet. Street intersection horizontal alignment shall be as near to 90 degrees as possible $\pm 5^\circ$ maximum. The grade of an intersecting street shall not exceed 4% and have a 50-foot long tangent minimum.

3.2.3 CUL-DE-SACS. Cul-de-sac streets shall not exceed 2800 feet in length and must include turnarounds no further apart than seven hundred (700) feet in accordance with Enoch Engineering Standards.

Cul-de-sacs must be terminated in a turn-around in accordance with Enoch City Engineering Standards. If surface water drainage is into the turn-around due to the grade of the streets, necessary catch basins and drainage easements shall be provided. Where a street is designed to remain only temporarily as a dead-end street, an adequate temporary turning area shall be provided at the dead-end thereof to remain and be available for public use so long as the dead-end exists. A fire hydrant will be required at the end of each Cul-de-sac.

3.2.4 STREET ACCESS. The number of access points onto City streets shall be kept to a minimum. The following information shall apply when designing street access for all developments.

- I. Direct access will not be allowed for parking, loading or driveway areas that require backing maneuvers onto major collector or arterial streets.
- II. Residential and commercial developments will be required to provide at least two (2) improved accesses to the development when the combination of dwelling units and commercial lots exceeds 80. The accesses shall be proper widths to accommodate the calculated traffic volumes when the area is fully developed. Design volumes for various street widths are shown in Table 3.1. Projected traffic volumes shall be calculated at the rate of 10 vehicles per day each direction per potential dwelling unit.
- III. No covered driveways will be allowed unless approved by the City.
- IV. Per Enoch Subdivision Ordinance Chapter 3, Section 3.2(2): Every new development, additional development, or redevelopment proposal submitted to Enoch City that generates (100) or more peak hour trips (using ITE Manual), and will have a significant impact on Enoch City's transportation system as determined by the Enoch City Engineer, will include a traffic impact impact

study (TIS). As part of the process on Development, UDOT will be included as a technical resource for any development that will generate (200) or more new peak hour trips (use ITE Manual).

3.2.5 CURB SIDE MAIL BOXES. Curb side mail boxes shall be installed according to the standard drawings and shown on the final subdivision plat.

3.2.6 SIGNS. All signs required in City streets shall be installed by the developer according to the standard drawings.

3.2.7 TEMPORARY STREETS. When streets are installed through undeveloped areas where water and sewer service lateral locations cannot be determined; a temporary street section as shown on standard drawing R5 can be installed.. This temporary street section shall be removed and replaced with the required street section when the area is developed. Temporary street sections shall only be used for the following: (1) master-planned streets that are not part of a development; and (2) the required second access for the development.

3.2.8 ACCESS CONTROL. No driveways or other access points will be allowed within 150 feet of the intersection of two arterial streets or the intersection of an arterial street with a major collector measured from the right-of-way line to the leading edge of the driveway. Driveways and/or other access points along all arterial streets shall be no closer than 100 feet measured between the nearest edges of the driveways.

3.2.9 ASPHALT TAPERS. Where the width of road asphalt narrows, a fifty (50) foot long asphalt taper shall be installed. Asphalt tapers shall be according to the Standard Drawings.

3.3 DRAINAGE SYSTEM DESIGN. All subdivisions in Enoch City shall be designed to accommodate rainfall and underground spring runoff in systems separate and independent from the sanitary sewer system. Hydrology studies shall be required as part of the design.

3.3.1. SPRING CONTROL. When in the determination of the City spring control is necessary, the owner shall provide an adequate pipe system to eliminate the nuisance of overland flow.

3.3.2. FLOOD CONTROL AND DRAINAGE SYSTEM IMPROVEMENTS. Prior to altering the natural terrain, developers shall consult with the City Engineer and perform a drainage study to determine the flood control and storm water drainage measures which are necessary in order to provide for the conveyance of such flood and storm waters through their project area in furtherance of the protection of public safety. A flood control and storm water drainage system shall be designed and approved as part of the Construction Drawings. Floodwater and storm drainage water may be conveyed in pipes, major washes, designated floodway easements, or dedicated city streets. Where open ditches or canals exist within or adjoining a residential or commercial subdivision or residential or commercial project requiring a building permit, the developer/owner may be required to pipe the channel or ditch or make other improvements to property belonging to a third-party, canal or irrigation company. Under such circumstances, developers shall coordinate with the canal or irrigation company to accommodate safety or flood control needs of the

project. Any proposed use or modification of canal or irrigation company property for such purposes will require canal or irrigation company approval. In order to provide for the public safety and protect against flooding, the City Engineer shall review any proposed modifications to or use of irrigation or canal company property. Review and approval of flood control and/or storm water drainage measures which propose the use or modification of irrigation or canal company property or facilities by the City will be limited to protection of public safety. Completion of canal or irrigation channel improvements, and coordination with a canal or irrigation company shall not unreasonably delay acceptance of the project's public improvements, issuance of building permits, or issuance of certificates of occupancy as long as the City Engineer determines that public safety issues have been adequately addressed.

Design of flood control systems shall meet all required improvements shall be designed and installed to City Engineering Standards.

3.3.3. CURB & GUTTER. Minimum curb and gutter grade shall be 0.50% (0.50 foot elevation difference in 100 feet of curb length).

3.3.4. MINIMUM PIPE SIZE. Minimum culvert size shall be 18-inch diameter and up depending on need for location. Minimum storm drain size shall be 18-inch diameter.

3.3.5. MINIMUM PIPE SLOPE: Culverts and storm drain shall be sloped sufficient to maintain 3 feet per second flow velocity flowing half full, or a 0.30% minimum slope whatever is greater.

3.3.6. STORM DRAIN MANHOLES. Manholes shall be installed at all changes in grade, direction, and size. Distances between manholes and/or in-line inlet boxes shall be no greater than 500 feet apart. All manholes shall be accessible to maintenance vehicles, and all easements shall provide at least 20 feet of unobstructed width. Floor troughs shall be furnished for all pipes entering manholes, and shall be at least as deep as the full diameter of the pipe in the manholes.

When pipes join in a manhole, the pipe flow line elevation of the outlet pipe shall be 0.10 feet lower than the inlet pipe.

All manholes shall conform to the detailed dimensions, construction details and materials as shown in the standard drawings. Manholes shall also conform to the conditions as detailed in Section 3, of these standards.

3.4 SANITARY SEWER DESIGN.

3.4.1 DESIGN FLOWS. All sanitary sewers and appurtenances shall be designed to carry the design flows from all contiguous areas that may be tributary thereto. Studies may be required to determine sewer design flow and adequate gravity and pressure sewer infrastructure sizes.

Sanitary sewers shall be designed to carry the peak discharge as specified below; also, all sewers shall be designed to transport suspended material so as to preclude the deposition of any solids in the sewer line.

New sewer systems shall be designed on the basis of an average daily per capita flow. Sanitary sewer systems shall be designed to prohibit infiltration and ex-filtration. To provide for peak loads, sanitary sewers shall be designed to carry, when full, not less than that shown in table 3.2.

**TABLE 3.2
SANITARY SEWER DESIGN FLOWS**

Laterals and Mains (< 15" diameter)	400 gallons/capita/day
Outfall Lines (≥ 15" diameter).	250 gallons/capita/day

All sewers shall be designed and constructed with hydraulic slopes sufficient to give mean velocities (when flowing 2/3 full) of not less than 2.0 feet per second, based on Manning's formula, using a value for "n" of not less than 0.013. The minimum slopes to be provided shall be as shown in table 3.3, unless approved otherwise by the City Engineer.

**TABLE 3.3
SANITARY SEWER MINIMUM SLOPES**

SEWER SIZE (Inches)	MINIMUM SLOPE (ft/100 feet)	MAXIMUM NUMBER OF DWELLINGS
4	1.00	3
6	0.60	10
8	0.50	300
10	0.40	500
12	0.35	750
15	0.30	1200
18	0.25	1900
21	0.20	2600
>24	0.15	3200

NOTE: Maximum dwelling units for four (4") and six inch (6") pipe sized for service laterals, eight inch (8") and above sized for sewer main.

The Engineer must furnish computations for velocities and depth of flow for grades in excess of 10% and for extremely low flow situations. No grades in excess of 15% will be allowed.

3.4.2 MINIMUM SIZE AND DEPTH. No public sanitary sewer shall be less than eight inches in diameter. Minimum size of house connections shall be four-inches (4”) in diameter. Minimum size of restaurant connections shall be six-inches (6”) in diameter. Only one residence, structure, or building in separate ownership shall be served by each lateral connected to the public main. (See Uniform Plumbing Code)

In general, sanitary sewers shall be designed to a depth of 9 feet to the pipe invert to permit sewer laterals from basements to be connected. Exceptions may be granted in subdivisions or areas in which basement-less buildings are to be constructed. In such case a note to that effect shall be made on all plans presented for approval. In no case shall sanitary sewers be designed for a depth of cover less than 36 inches over the top of the sewer pipe. All sewers shall be designed to prevent damage from superimposed loads as well as trench loading conditions.

3.4.3 ALIGNMENT. In general, all sanitary sewers shall be designed for uniform slope and alignment between manholes and shall be laid a distance of at least 10 feet (horizontally) from any existing or proposed water main. In the event that a sewer main cannot be laid at least 10 feet from an existing or proposed water main, then the City Engineer may authorize the implementation of the provisions of the State of Utah Public Drinking Water Regulations. Sewer mains and manholes shall be located in improved dedicated City streets. City owned sewer mains and manholes shall not be permitted on private property or behind homes unless no other alternative exists to provide gravity flow in the sewer main. The inability to provide gravity flow from the home shall not be a justification for the sewer mains not being located in the street. Sewer mains not located in improved dedicated City streets shall have a utility maintenance access. Sewer mains not located in improved dedicated City streets shall require a twenty (20) foot wide minimum easement for access and maintenance.

All Sewer laterals shall intersect the sewer main on the top third of the sewer main pipe as shown in the standard drawings and extend perpendicular from the sewer main pipe to the lot.

3.4.4 SERVICE CONNECTIONS. Service connections to any public sanitary sewer shall be made only to a wye installed at the time of the sewer main installation or by a machine tap and approved saddle wye or “insert-a tee” compatible with existing main line sewer material in accordance with the standard drawings and shall be a minimum of 10 feet, measured horizontally, from any culinary water line or tapping. All connections and service lines must be watertight. All sewer clean-outs shall be made according to the standard drawings. New subdivisions shall install a sewer lateral per the standard drawings on the main sewer for each proposed lot. The lateral shall be located 10 feet from the low lot line.

No service connection shall be made to any sewer outfall line with a diameter greater than 15 inches. A smaller sewer main will need to run to the nearest manhole.

All sewer laterals connected to public sewer mains shall conform to table 3.4.

All restaurants, food service establishments and other buildings that use high amounts of grease or oil shall have grease, oil, and sand interceptors with sampling manhole as specified in Section 3.4.7.

**TABLE 3.4
SANITARY SEWER LATERALS**

TYPE OF UNIT OR RESIDENCE	MINIMUM SEWER LATERAL SIZE (Diameter)	MINIMUM SLOPE
Single Family Residences	4 inches	2%
Town-homes	4 inches/unit	2%
Commercial Establishments	6 inches	1%
Mobile Homes	4 inches	2%
Apartments/Multi-Family Condominium Complexes	See notes below	

NOTES:

- 1) Lateral size and slope shall be based on the number of fixture units in the apartment or multi-family condominium complexes, in accordance with the International Plumbing Code.
- 2) Under no circumstances shall roof drains, foundation drains, storm drains or sub-drains be connected to the sanitary sewer system.

3.4.5 SEWER MANHOLES Manholes shall be installed at all changes in grade, direction, size, or at all intersections; and at distances no greater than 400 feet apart for main lines and 500 feet apart for outfall lines. All manholes shall be accessible to maintenance vehicles, and all sewer easements shall provide at least 20 feet of unobstructed width. Drop manholes shall be provided for a sewer line entering a manhole at an elevation of 18-inches or more above the manhole invert. Floor troughs shall be furnished for all sewers entering manholes, and shall be at least as deep as the full diameter of the sewer main in the manhole.

When a smaller sewer main joins a larger sewer main in a manhole, the top of pipe elevations shall match.

All manholes shall conform to the detailed dimensions, construction details and materials as shown in the standard drawings. Manholes shall also conform to the conditions as

detailed in Section 3, of these standards.

Sewer manholes for all sewer mains of 12 inches or less in diameter shall be a minimum of four feet (4') in inside diameter. For sewer mains larger than 12 inches in diameter or over 12 feet in depth, or for three (3) or more 8" or greater sewer lines flowing into a manhole, the manholes shall be not less than five feet (5') in inside diameter.

3.4.6 SEWER LIFT STATIONS Normally all City sanitary sewer mains shall be gravity flow type. Sewer lift stations shall only be permitted and designed according to the following criteria and design standards:

- I. Lift stations are allowed when a gravity flow sewer main would have a depth in excess of 25 feet for 10 percent or more of the sewer main length or the gravity flow sewer main would be longer than 300 feet multiplied by the potential number of sewer connections served by the sewer main.
- II. Minimum design standards and drawings for sanitary lift stations shall include a system design study report showing the pump and wet well design for the potential area served with a discharge pipe designed for a minimum flow velocity greater than 2 feet per second and a maximum velocity less than 5 feet per second. Duplex self-priming pumps (Gormann-Rupp or equal) shall be used for total system head less than 100 feet. All pumps shall be 480 volt/3-phase with auxiliary power connections and gas driven stand by generators or motors. Self-Priming pumps shall have walk-in pump enclosures with masonry walls, metal roof, interior/exterior lights, heat, vent fans, 15-gallon trash can, storage cabinet, wash down sink, faucet and drain, 120 volt electrical outlets and service water. All lift station designs shall have a site and grading plan per Standard Drawing S7 showing fenced yard with 6-foot chain link fence, 16-foot gate, 3-inch drain rock ground cover, sloped at 2% from wet well to the fence, 20-foot minimum set-back from the fence to the enclosure and/or lift station equipment, a SCADA system with radio communications, antenna, PLC or an auto dialer with wet-well high level, motor run, motor fail and intrusion alarms. Also included in the lift station design package shall be a design for the pressure discharge pipe (green or purple PVC C-900 DR-18) with thrust blocks, restraint joints, clean-outs, blow-offs, and in-line gate valves spaced at 1000 feet maximum, pipe locate wire (12-gage copper with terminal boxes), locate posts, pressure line/manhole connection detail. All installation and testing shall comply with the requirements of the equipment manufacture and City Engineering Standards. Refer to Standard Details for additional requirements and specifications for sewer lift stations. Where lift stations are not on the City's sewer master plan, the lift station shall be designed to ultimately be eliminated and connected to future gravity flow sewer.

3.4.7 GREASE, OIL, AND SAND INTERCEPTOR WITH SAMPLING

MANHOLE. Grease, Oil, and Sand Interceptors, shall mean a device for separating and retaining waterborne fats, oil, and greases before the wastewater exits the interceptor into the city’s wastewater collection system or Publicly Owed Treatment Works (POTW). The interceptor also collects settleable solids generated by or incidental to commercial, industrial and/or food preparation activities. The calculations for future grease interceptor capacity will be based on available tenant space, and/or flow through retention time. The Interceptor shall at a minimum be equipped with a two-cell construction and be constructed of impervious materials capable of withstanding abrupt and extreme changes in temperature. All grease, oil and sand interceptors shall conform to detailed dimensions, construction details and materials as shown in the standard drawings, and the Enoch City Pretreatment Ordinance. A sampling manhole shall also be installed with each grease, oil and sand interceptor. The sampling manhole shall conform to the engineering standards and standard drawings for sewer manholes as contained here-in.

3.5 CULINARY WATER DESIGN. All culinary water mains and appurtenances within Enoch City shall be designed to provide for adequate future service for all contiguous areas that may, within a reasonable period in the future, be tributary thereto.

3.5.1 DESIGN FLOW PRESSURE. Water mains shall be designed to provide a minimum residual pressure of 20 psi under maximum day demand conditions including designed fire flow (as called out in Section 3.5.7 of these Standards). A minimum of 35 psi residual pressure must be maintained under normal peak hour conditions without fire flow.

3.5.2 PEAK INSTANTANEOUS FLOW: Peak instantaneous flow as determined in ~~Section 5.1~~ of the State of Utah Public Drinking Water Regulations, shall be as follows:

Residential (indoor use -- not including fire flow):

$$Q_i = 10.8 N^{0.64}$$

where:

Q_i = Total indoor flow (in gpm) delivered to all connections.

N = Total number of equivalent residential connections.

Peak instantaneous flow shall be assumed for outdoor use as follows:

$$Q_o = 1.85Q_i$$

where:

Q_o = Total outdoor flow (in gpm) delivered to all connections.

$Q_i = Q_i$ as defined above.

Peak instantaneous total flow Q_t shall be: $Q_t = Q_i + Q_o$

Peak instantaneous fire flows shall be added to peak instantaneous domestic flows for distribution system design flow total.

Commercial or industrial areas may require special investigation to determine fire flow requirements. Existing and future static pressure and flow information used in the design must be obtained from or approved by the City Engineer.

3.5.3 MINIMUM SIZE AND DEPTH. The minimum depth of cover (to the top of the pipe) for water mains shall be three feet (3') below the final grade of the street. Where final grades have not been established, mains shall be installed to a depth great enough to insure three feet (3') of cover below future grade based on the best information available. The water mains shall be sized to deliver the peak instantaneous flow rate as determined in Section 3.5.2. The fire flow requirements and pressures shall be as outlined in Section 3.5.7. The minimum size water mains serving any fire hydrant shall be eight-inches (8") in diameter unless hydraulic analysis indicates the required flow and pressures can be maintained by a six-inch (6") diameter line.

3.5.4 VALVES AND HYDRANTS. The water distribution system shall be looped as outlined in Section 3.5.7.II and valves shall generally be spaced such that a break in any one length of main will put no more than 1000 feet of main nor more than three (3) fire hydrants out of service (whichever is less) while maintaining adequate minimum service in the remainder of the water system during repairs. Valves in transmission mains shall be spaced at maximum intervals of one (1) mile. All distribution mains connecting to transmission mains shall be valved at the connection. All fire hydrant runs shall also be valved.

Valves generally shall be located at street intersections where the water mains connect.

Valves 8-inches and smaller shall be Gate Valves and all valves larger than 8-inches shall be Butterfly Valves.

3.5.5 PRESSURE REDUCING VALVES: The Enoch City Water Department recommends that in high-water-pressure zones in the City, secondary pressure reducing devices be installed by the owner on all water connections to buildings. The locations of the high-water-pressure zones within the City can be located and identified upon request from the Enoch City Water Department.

3.5.6 FIRE HYDRANT SPACING AND LOCATION: Generally, fire hydrants shall be spaced and located as follows:

- I. At each intersection, on the end of a cul-de-sac and generally on the same sides of the street.
- II. In residential areas, fire hydrant spacing shall be no greater than 500 feet and no house shall be more than 250 feet from a hydrant via a street access to the property being served.

III. In multiple family areas, P.U.D. zones, industrial, business or commercial areas, fire hydrant spacing shall require special investigation to determine the hydrant spacing per the International Fire Code.

IV. Generally, hydrants shall be located in line with extensions of the property line when located mid-block.

V. Hydrants shall be placed at least one foot (1') from the back of the sidewalk, with a three-foot (3') elliptical radius of clearance to adjacent obstacles and with the lowest water outlet not less than 18 inches nor more than 30 inches from the final ground elevation. (See standard details)

VI. All fire hydrants to be installed on dedicated easements or public rights-of-way will be owned and maintained by the Enoch City Water Department.

3.5.7 FIRE FLOW REQUIREMENTS: Under maximum day demand conditions, fire flow shall be according to the latest International Fire Code. The total system design shall be such that fire flows and normal peak instantaneous flow demand (as called out in Section 3.5.2 of these standards) can be met while still maintaining a minimum pressure of 20 psi at all points in the distribution system.

High-density residential, commercial or industrial areas shall require special investigation to determine fire flow requirements and hydrant spacing per International Fire Code. Existing and future static pressure and flow information used in the design shall be obtained from or approved by the Enoch City Water Department.

3.5.8 MISCELLANEOUS WATER SYSTEM DESIGN CRITERIA.

I. All public water mains shall be installed in an easement at least 10 feet in unobstructed width or in public rights-of-way with adequate access for maintenance vehicles.

II. Permanent dead-end mains shall be avoided wherever possible and if installed, shall not exceed 500 feet. Connections on any dead-end water main shall not exceed 250 equivalent residential units. Hydrants shall be located at the end of dead-end mains for flushing purposes as well as for fire protection. Blow-off valves rather than fire hydrants shall be used for initial line blow-off or blow-out after line repairs have been made. Blow-off valves shall be installed per the standard drawings.

III. Each building shall be served by a separate line and meter except in PUD's as approved by the City Engineer; however, in some situations a common tap and service line from the main to a manifold with two (2) meter setters and boxes may be installed to serve two (2) adjacent properties. All lots shall have a minimum of 1" service line from the main to the meter box.

IV. All service line taps shall be machine tapped at the time of the water main installation. Service lines shall be installed prior to testing and acceptance of the water main.

V. Water mains shall be laid at least 10 feet horizontally from any existing or proposed sewer main. The distance shall be measured edge to edge. If necessary and where approved by the City Engineer, the State of Utah Public Drinking Water Regulations can be implemented.

VI. When a water main crosses over a sewer main, the water main shall be laid at such an elevation that the bottom of the water main is at least 18 inches above the top of the sewer. When the water main cannot be as high as 18 inches above the sewer, the sewer shall be constructed of material with pressure conduit standards for a distance of 20 feet on either side of the crossing.

VII. All tees, bends, plugs and hydrants shall be provided with reaction blocking, tie rods, and joints designed to prevent movement, i.e. "mega lug" or approved equal. Wood blocking of future main extensions are not acceptable. Concrete thrust blocks shall be formed and poured in place and must bear against undisturbed soil, per the thrust block details in the standard drawings.

VIII. Air release-vacuum assemblies and blow-off valves shall be provided on all mains larger than 12 inches where required to prevent damage due to air accumulations.

IX. No access to water meters or fire loop leak detectors shall be placed in driveways, parking stalls or sidewalks.

X. All subdivisions shall install sample station #88-SS per standard drawing. One sample station per 80 homes in a multi-phase subdivision.

3.6 OTHER UTILITIES SYSTEMS DESIGN. All other utility systems within Enoch City shall be designed to meet the following specifications:

3.6.1 RESPONSIBILITY. Other necessary utility installations, (Gas, Electricity, Phone, and T.V.), will be coordinated by the developer.

3.6.2. SAMPLE STATION. Shall be placed within designated utility easements as shown in the standard drawings.

3.6.23 STREET LIGHTS. All developments shall include street lights and necessary wiring installed at the owner's expense in accordance with these standards and the local power company's specifications.

3.6.34 BURIAL OF LINES. All subdivision and planned unit development utility lines

(Gas, Electricity, Phone, and T.V./Internet), shall be underground. Lines shall be buried at a minimum depth of 32". No lines shall be buried in any water or sewer trench.

3.6.45 LAYOUT. Utility lines shall be placed within designated utility easements as shown in the standard drawings.

3.6.56 FRONT LOT LINE SYSTEMS. Where front lot lines are used, they must be complete before installation of street asphalt.

3.6.67 QUALITY CONTROL. All utility trench construction shall conform to the design and testing requirements set forth in Section 4.2 (pipeline construction) of these standards.

SECTION 4

CONSTRUCTION STANDARDS

4.1 EARTHWORK. This section defines the requirements for excavation and backfill for structures; construction requirements for embankments and fills; subgrade preparation for pavements and other surface improvements.

4.1.1 DEFINITIONS:

I. EMBANKMENT shall refer to any raised area of compacted earth to support a roadway, structure, parking lot, etc. The material used for embankment shall be specified, and tests shall be performed to determine the fill material's adequacy for the specific project.

II. FILL shall refer to any material used to fill a depression, and can be any material which can be compacted enough to prevent settlement such as earth, broken-up concrete, old building blocks, crushed stone or material from a riverbank, etc. (Embankment is a type of fill.)

III. BACKFILL shall refer to any earth that has been excavated from a trench or other excavation and then replaced and compacted as specified after the structure has been installed.

IV. SUBGRADE shall refer to the native, prepared original soil or engineered fill under any roadway, fill, embankment, structure, etc.

V. MAXIMUM DRY DENSITY as determined by ASTM D 1557.

4.1.2 MATERIALS. Earthwork materials in City improvements shall conform to the following:

I. EXCAVATION. All structures shall be founded on prepared original soil or engineered fill. All unauthorized excavation below the specified structure subgrade shall be replaced with concrete or untreated base course thoroughly compacted to a minimum of 95% of maximum dry density. Subgrade soil for all concrete structures, regardless of type or location, shall be firm and thoroughly compacted to a minimum of 95% of maximum dry density for granular soils or 90% of maximum dry density for silty/clay soils as classified by AASHTO M-145 soil classification system.

II. COARSE GRAVEL. Coarse gravel or crushed stone may be used for subsoil reinforcement when approved by the City. Such material shall be applied in six-inch (6") layers, each layer being embedded in the subsoil by thorough tamping. All excess soil shall be removed to compensate for the displacement of the gravel or crushed stone, and the finished elevation of any subsoil reinforced in this

manner shall not be above the specified sub-grade.

III. BACKFILLS. Backfill shall be placed to the lines shown on the approved drawings, or as directed by the City Engineer. After completion of construction below the elevation of the final grades, and prior to backfilling, the excavation shall be cleaned and all forms, trash and debris shall be removed. Backfill material shall consist of approved excavated material or clean borrow sand, gravel or other suitable material, and shall be placed in layers compatible with the equipment and not exceeding twelve inches in compacted thickness. Each layer shall be compacted to a minimum density of 95% of maximum dry density for granular soils, or 90% of maximum dry density for silty/clay soils as classified by AASHTO M-145 soil classification system.

4.1.3 CONSTRUCTION METHODS. The methods employed in performing the work shall be the responsibility of the developer. The developer shall make such changes in the methods employed as are necessary to install an acceptable finished product. These methods shall include but are not limited to the following:

I. CONSTRUCTION OF EMBANKMENTS. Unsuitable materials that occur in the foundations for embankments shall be removed by clearing, stripping and/or grubbing. Soils used as roadway embankment material shall be approved by a licensed geotechnical engineer or the City Engineer. All materials in embankments shall be placed, moistened, and compacted as provided in the following paragraphs.

When the embankment exceeds the amount of excavation, sufficient additional material shall be obtained from borrow pits provided by the Contractor. All material proposed to be imported shall be subject to the review and approval of the City Engineer prior to starting of hauling operations. The materials used for embankment construction shall be free from sod, grass, trash, rocks larger than six inches (6") in diameter and all other material unsuitable for construction of embankments. The material shall be a granular material as classified by AASHTO M-145 soil classification system.

Grading of completed embankments and backfills shall bring the surfaces to a smooth, uniform condition with final grades being within 0.1 foot of the design grade. Cut and fill slopes shall be 2:1 (H:V) maximum. Construction of slopes steeper than 2:1 (H:V), or fills in excess of 5 feet, shall be approved by the geotechnical engineer of record for the project or the City Engineer.

II. COMPACTION OF EARTH MATERIALS. The fill material shall be deposited in horizontal layers having a thickness of not more than twelve inches (12") and then compacted to the specified density as herein specified. Moisture content during compaction operations shall be within two % optimum for granular soils and at two to five % above optimum for fine-grained soils. The moisture content shall be uniform throughout the layers.

If the moisture content is greater than specified for compaction, the compaction operations shall be delayed until such time as the material has dried to the optimum moisture content. When the material has been conditioned as herein specified, the backfill or embankment shall be compacted as follows:

Under roadways, curb and gutter, sidewalks, and driveways, and extending one foot beyond the proposed construction, the embankment material shall be compacted to a density equal to not less than 95%. Other fills and embankments not listed above shall be compacted to 90% maximum dry density.

Exposed natural soils within building areas, beneath walkways, slabs and pavement shall be scarified to a depth of eight inches (8”), moisture conditioned, and compacted to the specified density. Where hard, cemented material or rock is exposed, scarification is not necessary.

Foundations for structures shall not be placed partially on undisturbed soil or compacted fill and partially on cemented deposits or rock.

Foundation soils shall not be allowed to become saturated during or after construction.

III. SUBGRADE PREPARATION. The original soils under roadways, curb and gutter, sidewalks, and driveways shall be scarified to a depth of eight inches (8”) prior to compaction operations. All road subgrade shall be compacted to the equivalent of 95% of maximum dry density for granular soils or 90% of maximum dry density for silty/clay soils as classified by AASHTO M-145 Soil Classification System. No organic material, soft clay, spongy material or other deleterious material will be permitted in the subgrade. Subgrades shall be shaped and graded to within a tolerance of 0.10 foot of design grade and drainage shall be maintained at all times. Subgrades shall be stabilized and compacted as directed by the geotechnical engineer or the City Engineer. Any springs or underground water encountered in the construction of the streets shall be properly disposed of in accordance with the instructions of the City Engineer.

When required to demonstrate the stability and compaction of the subgrade, the contractor shall proof-roll the subgrade prior to laying any base gravel. The subgrade shall be proof-rolled with at least one pass coverage with a pneumatic tired roller of at least ten-ton capacity. All proof-rolling shall be accomplished in the presence of the engineer of record. Ground contact pressure for all tires shall be 85 to 90 psi.

When the proof rolling shows an area to be unstable, it shall be brought to satisfactory stability by additional compaction, reworking, or removal of unsuitable material and replacement with acceptable material.

IV. CONSTRUCTION OF NON-STRUCTURAL FILLS. Fills shall be placed to

the lines shown on the drawings and shall be any areas not specifically designated for support of structures or utilities (such as landscape areas, open space areas, etc.). Fill material shall have no specific compaction requirements but shall consist of material that can be compacted to prevent settlement such as rocks, old building blocks, crushed stone, broken-up concrete, boulders, etc. Fill material shall not include deleterious materials such as muck, ash, sod, grass, trash, tree stumps, lumber, dead animals, etc.

4.1.4 QUALITY CONTROL. All earthwork shall be performed in accordance with these standards and shall be tested and accepted as follows:

I. TESTING. Minimum testing of earthwork shall be as follows:

Soil Classification - One per material source. The sieve analysis shall be according to ASTM C136, C117.

Soil Proctor - One determination for each significant change in soil type as necessary to provide required compaction testing. Tests shall be ASTM D1557 (modified proctor).

Earth fill moisture/
density
determination - One test per 500 cubic yards of fill placed in an embankment. Tests shall be ASTM D1556 or D6938.

Subgrade moisture/
density
determination - One test per 1000 square yards of surface area. Moisture density determinations shall be made in accordance with Section 3 of the City Standards. Tests shall be ASTM D1556 or D6938.

II. ACCEPTANCE. Any earthwork determined not to be in compliance with these standards shall be removed and replaced or reworked until compliance is obtained. Any costs for the rework or testing the rework shall be paid for by the developer.

III. EQUIVALENT TESTING METHOD. The equivalent AASHTO testing method may be used in place of the listed ASTM method listed. When the AASHTO testing method is used, note the equivalent test on the test results.

4.1.5 SPECIAL EARTH WORK REQUIREMENTS. In areas of Enoch City where a geotechnical investigation is required before development, the recommendations of the geotechnical report shall be followed. The requirements outlined previously in this section are only a minimum.

4.2 PIPELINE CONSTRUCTION: This section covers the requirements for material trenching, placement, backfilling, cleaning and testing of underground pipelines and incorporates the requirements of the AWWA Standards and Manufacturers Recommended Installation Procedures, whichever is more stringent. Backfill shall include filling of all trenches to the original ground surface or final grading elevation as shown on the drawings, or otherwise directed by the appropriate city departments.

4.2.1 MATERIALS. This section specifies acceptable pipe and accessories for public sanitary sewers, underground culverts, storm drains, and water pipe construction within Enoch City. The materials used for pipe and fittings shall be new and shall conform to the requirements for class, brand, size and material as specified.

I. SEWER PIPE: Only those pipes listed below may be used in the construction of sanitary sewer lines in Enoch City.

A. P.V.C. PLASTIC SEWER PIPE: This Specification covers rigid polyvinyl chloride pipe and fittings, hereinafter called PVC fittings. PVC pipe and fittings from 4 inches to 15 inches in diameter shall meet or exceed all of the requirements of ASTM Specification D3034 with a minimum wall thickness to diameter ratio of SDR-35. PVC pipe and fittings from 18 inches to 27 inches in diameter shall meet or exceed the requirements of ASTM F679.

Each pipe used shall have a manufacturer's stamp on it indicating that it complies with the requirements of the appropriate specification. Any pipe not so stamped shall be rejected.

All pipe shall be homogeneous throughout and free from cracks, holes, foreign inclusions or other defects. All PVC sewer pipe shall be made from clean, virgin, Type 1, Grade 1, Polyvinyl Chloride conforming to ASTM Resin Specification D 1784.

All pipe joints shall be bell and spigot type with rubber ring gasket to permit expansion and contraction. Pipe and fittings shall be assembled with a non-toxic lubricant. Pipes of 4-inch and 6-inch diameter may be the solvent weld type. Pipe shall have the following minimum SDR-35 dimensions:

NOMINAL PIPE SIZE (INCHES)	OUTSIDE DIAMETER (INCHES)	MINIMUM WALL THICKNESS (INCHES)
4	4.215	0.125
6	6.275	0.180
8	8.400	0.240
10	10.500	0.300
12	12.500	0.360

nds shall have a 15° tapered end with a memory mark around the diameter of the pipe to indicate proper insertion depth.

B. A.B.S. COMPOSITE AND SOLID WALL SEWER PIPE: This specification covers Acrylonitrile-Butadiene-Sturine (ABS) gravity sewer pipe. All ABS composite sewer pipe shall conform to the latest revision of ASTM Specification D2680. The ABS material used shall be a virgin rigid plastic conforming to rigid ABS plastics. The other component shall be Portland Cement, Perlite concrete, or other inert filler material exhibiting the same degree of performance.

All solid wall pipe used for laterals shall have a minimum wall thickness to diameter ratio of SDR-35. Fittings not described by these standards shall be shop fabricated or molded from materials listed in Paragraphs 4 and 5 of ASTM D2680 and shall be of equivalent quality to those described.

All field joints shall be chemically welded. Primer, then cement, shall be applied liberally to the outside of the spigot end and the inside of the coupling immediately prior to stabbing the pipe together. The pipe spigot end shall be supplied with home marks to assure proper jointing.

C. RIBBED PVC PIPE: Ribbed PVC sewer pipe (Ultra Rib by Uponor ETI or equal) may be used on all sanitary sewers and storm drains greater than 12-inch diameter when approved by the City Engineer. All ribbed pipe shall be seamless open profile and meet the requirements of ASTM F794 and Uni-Bell Uni-B-0. Pipe shall have a smooth interior with a solid cross-sectional rib exterior. Exterior ribs shall be perpendicular to the axis of the pipe to allow placement of the sealing gasket without additional cutting or machining. The pipe stiffness shall be a minimum of 46 psi when tested at 5% deflection in accordance with D2412. Pipe shall be green or white in color. The filler material used in the pipe (calcium carbonate) shall not exceed 10% by volume.

D. SEWER PIPE FITTING: All sewer and storm drain pipe fittings including service lateral connections, tees, repair couplings, etc., shall be of the same material and thickness class as the main pipe. Flexible couplings (i.e. Fernco Couplings) or cast in place concrete collars will not be allowed.

II. STORM DRAIN PIPES: All pipes listed under section 4.2.1.I "Sewer Pipes" of these standards as well as the following pipes may be used in the construction of storm drain lines and culverts in Enoch City.

A. NON-REINFORCED CONCRETE PIPE: Non-reinforced concrete sewer pipe may be used for storm drains up to and including 24-inch size unless otherwise specifically designated in these Standards or on the approved Drawings. Pipe shall be extra strength pipe manufactured to

comply with the requirements as set forth in ASTM Designation C14, Class 3 unless otherwise approved by the City Engineer. Joints shall be of the bell and spigot with rubber gasket design, and with joints and gaskets. Pipe joints shall be so designed as to provide for self-centering, and when assembled, to compress the gasket to form a watertight seal. The gasket shall be confined in a groove on the spigot so that pipe movement or hydrostatic pressure will not displace the gasket.

B. REINFORCED CONCRETE PIPE: Reinforced Concrete Pipe shall be used for all storm drains using concrete pipe greater than 24 inches in diameter. Reinforced concrete pipe shall comply with the requirements of ASTM C76 (Class II) unless otherwise approved by the City Engineer. Joints shall be of the bell and spigot design with rubber gasket type joints for storm drains, with an alternate option of tongue and groove mortar joints for elliptical pipe when approved by the City Engineer.

C. CORRUGATED POLYETHYLENE PIPE: Corrugated Polyethylene pipe shall be high-density polyethylene corrugated exterior/smooth interior pipe. 12 to 24-inch diameters shall conform to AASHTO M 294 Type S, or ASTM F2306. Materials shall conform to ASTM D3350. All pipe joints, gaskets, and fittings shall be water tight according to ASTM F2306, F477 and D3212 and conform to AASHTO M 294, and shall be approved by the City Engineer. Corrugated Polyethylene pipe shall not be used for any pipes larger than 24- inches. If cover over Corrugated Polyethylene pipe is less than 1 foot use flowable fill for backfill.

III. SEWER MANHOLES: This section covers the requirements for the materials used in sanitary sewer and storm water manholes. Manholes shall be watertight and be furnished complete with cast iron rings and covers as follows:

A. CONCRETE BASES: Manhole bases shall be pre-cast or cast-in-place. The concrete shall conform to the requirements of Section 4.4 of these Standards.

Where sewer lines pass through or enter manholes, the invert channels shall be smooth and semi-circular in cross section. Changes of direction of flow within the manholes shall be made with a smooth curve with the longest radius possible. The depth of the channel in the manhole base shall be the full diameter of the sewer pipe being used at that manhole. The floor of the manhole outside the flow channels shall be smooth and slope toward the channel at not less than one-half inch per foot or more than one-inch per foot.

B. WALL AND CONE SECTIONS: All manholes shall be constructed of either 48-inch or 60-inch inside diameter pre-cast, sectional, reinforced

concrete. Both cylindrical and taper sections shall conform to all requirements of ASTM C478 for pre-cast reinforced concrete manhole sections and shall have ladders according to the standard drawings.

Throat sections of manholes shall be adjustable by use of appropriate diameter pipe sections up to 18 inches in height.

The taper section shall be a maximum of 3 feet in height, shall be of eccentric conical design, and shall taper uniformly from 48 or 60 inches to 30 inches inside diameter. Cones shall be set on the manhole sections so that the top opening of the cone is centered over the centerline of the sewer.

60 inch inside diameter sewer manholes shall be required for all sewers greater than 18 inches in diameter or deeper than 12 feet, or where 3 or more 8-inch or greater lines converge in the manhole.

The base section of the manhole shall be furnished in section lengths of 1, 2, 3, and 4 feet as required.

All joint surfaces of pre-cast sections and the face of the manhole base shall be thoroughly cleaned prior to setting the sections. Joints shall be sealed with a one-inch flexible joint sealant, which shall conform to the requirements of ASTM C923.

C. WATER-TIGHTNESS. Water-tight concrete shall be required in all concrete manholes. Any cracks or imperfections developing at any point in the work shall be satisfactorily repaired. Materials and methods used shall be subject to approval of the City Engineer.

D. IRON CASTINGS. All iron castings shall conform to the requirements of ASTM A48 (Class 30) for gray iron castings. Frames and covers shall have a minimum combined weight of 402 pounds.

The cover and ring seat shall be machined so that the entire area of the seat will be in contact with the cover, in any position of the cover on the seat. Frames and covers shall be so constructed and machined that the parts are interchangeable. The tops of the cover and frames shall be flush, and the clearance between the frame and cover shall be 1/8 of an inch all around. The top surface of each cover shall be cast with a ribbless cross hatch design including the word "Sewer". Letters and design shall be recessed 1/4". Each cover shall be provided with not less than twelve ventilating holes of 3/4-inch diameter each.

All manhole frames shall be carefully set to the finished grade or as directed by the City Engineer. Manhole frames shall be set in place on the manhole

throat and shall be sealed with an approved flexible joint sealant that shall conform to the requirements of ASTM C923. Frames or covers loosened from the manhole throat shall be reset and any frames, covers or throat sections damaged or broken, shall be replaced prior to acceptance by the City.

E. MANHOLE STEPS. Manhole steps shall be constructed in accordance with the drawing "Manhole for Sanitary & Storm Sewer" as shown in the standard drawings of these standards and shall be similar in construction to the manhole step as manufactured by M.A. Industries, Inc., of Peachtree City, Georgia.

The steps shall be constructed of number four (one-half-inch diameter) grade 60 reinforcing steel bars bent and embedded in Copolymer Polypropylene Plastic.

The Copolymer Polypropylene Plastic, used to embed the reinforcing bars in, shall conform to the requirements of ASTM D4101, and the reinforcing bar shall conform to the requirements of ASTM A615.

Manhole steps shall be installed at intervals not to exceed 16 inches between steps, be firmly cast into the concrete wall and taper sections of all manholes to a minimum depth of 3-3/8 inches, as shown in the drawings, and form a solidly anchored step which will not pull out or break under repeated use.

IV. WATER PIPE AND FITTINGS. The materials used for pipe and fittings shall be all new and shall conform to the requirements for class, brand, size and material as specified.

A copy of the manufacturer's installation recommendation for each kind of pipe shall be provided to each foreman prior to construction. These recommendations shall be followed during construction unless instructed otherwise by the City Inspector or Engineer. All pipe materials are as follows:

A. GENERAL PIPE REQUIREMENTS: Pipe materials shall conform to the following:

SIZE	TYPE
1/2" - 3"	Polyethylene (PE) Pressure Pipe AWWA C901 Polyvinyl Chloride (PVC) Rigid Plastic Pipe ASTM D1785
4" - 60"	Polyvinyl Chloride (PVC) Pressure Pipe

	AWWA C900
--	-----------

B. CONNECTION WATER METERS: Only authorized employees of the City Water Department shall be allowed to connect or disconnect water meters. All boxes set in concrete shall comply with Enoch City Engineering Details.

NOTE: Where these Standards refer to AWWA Standards, a copy of these standards is available for review at the Enoch City Water Department or at the Enoch City Office.

C. POLYETHYLENE (PE) PRESSURE PIPE ½”-3”: All Polyethylene (PE) Pressure Pipe shall be Pressure Class 200, SIDR 7 conforming to the latest edition of AWWA Specification C-901. Unless otherwise specified, all PE pipe furnished under these specifications shall be constructed of ASTM PE3408 Materials. The maximum allowable variation to the standard pipe thickness shall not be more than those shown in Table 4.1a:

**TABLE 4.1a
POLYETHYLENE PIPE TOLERANCE**

NOMINAL PIPE SIZE (INCHES)	POSITIVE TOLERANCE (INCHES)
½”-1”	0.020
1¼”	0.024
1½”	0.028
2”	0.035
2½”	0.042
3”	0.053

D. POLYVINYL CHLORIDE (PVC) RIGID PLASTIC PIPE ½”-3”: All Polyvinyl Chloride (PVC) Rigid Plastic Pipe, when required, shall be Schedule 40 conforming to the latest edition of ASTM D1785. Unless otherwise specified, all PVC pipe furnished under these specifications shall be constructed in accordance with ASTM D1784. The maximum allowable variation to the standard pipe thickness shall not be more than those shown in Table 4.1b:

**TABLE 4.1b
POLYETHYLENE PIPE TOLERANCE**

--	--

NOMINAL PIPE SIZE (INCHES)	POSITIVE TOLERANCE (INCHES)
½"-2"	0.020
2½"	0.024
3"	0.026

E. POLYVINYL CHLORIDE (PVC) PRESSURE PIPE 4"-12": All Polyvinyl Chloride (PVC) Pressure Pipe shall conform to the latest edition of AWWA Specification C900. Unless otherwise specified, all PVC pipe furnished under these specifications shall be constructed in accordance with ASTM D1784. The maximum allowable variation to the standard pipe thickness shall not be more than those shown in Table 4.1c:

**TABLE 4.1c
POLYVINYL CHLORIDE PIPE TOLERANCE**

NOMINAL PIPE SIZE (INCHES)	POSITIVE TOLERANCE (INCHES)
4"	0.041
6"	0.059
8"	0.078
10"	0.095
12"	0.113

F. POLYVINYL CHLORIDE (PVC) PRESSURE PIPE 12": All Polyvinyl Chloride (PVC) Pressure Pipe shall be DR-25, conforming to the latest edition of AWWA Specification C-905. Unless otherwise specified, all PVC pipe furnished under these specifications shall be constructed in accordance with ASTM D-1784. The maximum allowable variation to the standard pipe thickness shall not be more than those shown in Table 4.1d:

**TABLE 4.1d
POLYVINYL CHLORIDE PIPE TOLERANCE**

NOMINAL PIPE SIZE (INCHES)	POSITIVE TOLERANCE (INCHES)
14"	0.073
16"	0.084

18"	0.094
20"	0.104
24"	0.124
30"	0.154
36"	0.184

1. Compliance with "National Sanitation Foundation Standard No. 14 for Thermoplastic Materials" is required on all piping materials and the NSF seal of approval shall appear on the pipe.
2. Pipe joints shall be elastomeric gasketed joints, providing a water tight seal.
3. All fittings used on rigid PVC pipe shall be Class 125 grey or ductile iron and conform with AWWA Specification C110.
4. Couplings used on rigid PVC pipe shall be solid sleeve or transition type with mechanical joints complying with AWWA Specification C110.

G. DUCTILE IRON PIPE: All ductile iron pipe shall be Class 50 conforming to the latest edition of AWWA Specifications C-151. Pipe and accessories shall be gauged at sufficiently frequent intervals to insure that dimensions are in accordance with Table 51.3 and 51.4 of AWWA Specifications C-151 for the gauge in accordance with the Standard Dimensions. The inside diameters of the sockets and the outside diameters of the spigot ends shall be tested with circular gauges.

Unless otherwise specified, all Ductile Iron Pipe furnished under these Standards shall be designed in accordance with AWWA Specification C-150-76 "American National Standard for the Thickness Design of Ductile Iron Pipe." The maximum allowable variation with the standard pipe thickness shall not be more than those shown in table 4.1e and note:

**TABLE 4.1e
DUCTILE IRON PIPE TOLERANCE**

PIPE DIAMETER (INCHES)	MINUS TOLERANCE (INCHES)
3-8	0.05
10-12	0.06
14-42	0.07
48	0.08

Note: An additional tolerance of 0.02 inches shall be permitted over areas not exceeding 8

inches in length.

1. PHYSICAL AND MECHANICAL PROPERTIES: The Ductile Cast Iron Pipe shall conform to all requirements of the ANSI Specification A21.51. The physical properties shall not be less than 60-42-10.

Each pipe shall be subjected to a hydrostatic test of not less than 500 psi. The test may be made either before or after the standard outside coating and bituminous inside coating have been applied, but shall be made before the application of a cement lining or of a special lining. The pipe shall be under the full test pressure for at least ten (10) seconds. Any pipe that leaks shall be rejected.

2. MARKING: Each pipe shall be legibly marked "Ductile". The weight, a manufacturer's mark, and the year in which the pipe was produced shall be cast or marked on the pipe.

3. INSPECTION: The manufacturer shall establish the necessary quality control and inspection practice to assure compliance with these standards. The manufacturer shall, if required by the City Engineer, furnish a certified statement that the inspection and all the specified tests have been made and the results thereof comply with the requirements of these standards. When the City Engineer desires to inspect the pipe at the manufacturer's plant, the City Engineer will so specify and state the extent of the inspection. The City's inspector shall have free access to those parts of the manufacturer's plant that are necessary to assure compliance with these standards. The manufacturer shall provide the inspector with assistance to handle pipe as may be necessary.

4. REJECTION OF PIPE: At least one (1) tensile and one (1) impact sample shall be taken during each casting period of approximately three hours. Samples shall be selected to properly represent extremes of pipe diameters and thicknesses. If the results of any physical acceptance test fails to meet the requirements of these standards, all pipe cast in the same sampling period shall be rejected. The manufacturer may determine the extent of rejections by making similar additional tests of pipe until the rejected lot is bracketed (in order of manufacturer) by an acceptable test at each end of the period of question. When pipe of one size is rejected from a sampling period, the acceptability of pipe of different sizes from the same period may be established by making the routine acceptance test for these sizes.

5. JOINTS: Ductile Iron Pipe shall be either Mechanical Joints,

Rubber Gasket Slip-on Joints, Flanged Joints, or a combination of the above as specified on the plans.

a. MECHANICAL JOINTS. Mechanical joints and the rubber gaskets and lubricant for Ductile Iron Pipe shall comply with the requirements and be dimensioned in accordance with the latest edition of AWWA specifications C-104, C-110 and C-111.

Bolts and rubber gaskets shall be furnished with mechanical joint pipe in sufficient quantity for the amount of pipe ordered.

b. RUBBER GASKET SLIP-ON JOINT. Rubber gasket slip-on joints, and the rubber gaskets and lubricant for Ductile Iron Pipe shall comply with the general requirements of AWWA C-151 and C-111.

Rubber gasket slip-on joints shall be designed for assembly by pre-positioning of a single continuous molded rubber ring gasket in an annular recess in the pipe socket to form a positive seal. The plain end of the pipe shall be suitably beveled to facilitate assembly.

The design and shape of the gasket, and the annular recess therefore, shall be such that the gasket is locked in place against displacement as the joint is assembled. The gasket shall provide adequate compressive force between the plain pipe end and the socket after assembly to effect a positive seal under all combinations of joint and gasket tolerances.

Details of the joint and rubber ring gasket design and assembly shall be in accordance with the pipe manufacturer's standard practice. The pipe supplier shall furnish the City Engineer detailed drawings in quadruplicate showing the design of the joint prior to casting said pipe. The design of the joint shall be subject to the approval of the City Engineer.

The recess in the pipe socket for the rubber ring shall be free of all coating materials and sand pits.

Rubber gaskets and lubricant shall be furnished with rubber gasket joint pipe in sufficient quantity for the amount of pipe ordered.

c. FLANGED JOINTS. Cast iron pipe flanges, and bolts and nuts therefore, shall be dimensioned in accordance with ANSI B-16.2 for Class 200. Threads for screw-on flange pipe shall comply with ANSI B-21. Flange bolts, nuts and gaskets shall be furnished with flange joint pipe in sufficient quantity to make each joint for the pipe ordered. Flanged fittings and spools shall conform to AWWA C-104, C-110 and C-115.

6. LINING AND COATING: The waterway surfaces of all Ductile Iron water pipe and fittings shall be completely covered with a uniform thickness of cement-mortar which shall be further covered with a bituminous seal coat, all in accordance with AWWA C-104. The bituminous seal coat may be omitted if the cement lining is given a 7-day water cure during which the lining is kept consistently damp.

Ductile Iron Pipe or Fittings lined in the field will not be accepted as conforming to AWWA C-104.

The outside surface of all Ductile Iron Pipe for general use under all normal conditions shall have a bituminous coating of coal tar primer approximately 1 mil thick, unless otherwise specified. The finished coating shall be continuous and smooth. It shall be neither brittle when cold, not sticky when exposed to the sun, and shall strongly adhere to the pipe.

7. POLYETHYLENE WRAPPING: A polyethylene wrap will be required on all ductile iron pipe laid in corrosive soils or where directed by the City Engineer. The polyethylene wrap tubing shall be cut to provide for a minimum of one (1) foot of lap over both the adjoining pipes. The ends of the tubing shall be wrapped using three (3) circumferential turns of plastic adhesive tape. The loose wrap on the barrel shall be pulled snugly around the barrel of the pipe and the excess folded over at the top. This fold shall be held in place by means of six-inch (6") strips of plastic tape placed at intervals of three feet (3') along the pipe barrel.

Bends, reducers, and offsets shall be wrapped in the same manner as the pipe. Valves shall be wrapped by bringing the tube wrap on the adjacent pipe over the bells of the valve and sealing with adhesive tape. The valve bodies shall then be wrapped with flat sheets passed under the valve bottom and brought up around the body to the stem and fastened with the tape.

H. COPPER PIPE: Copper Pipe may be used for service lines that are two-inch (2") or less in diameter; type K copper pipe shall be used. Pipe that has outside dimensions greater than two-inch (2") in diameter shall not be copper. All copper pipe shall conform to the following specifications:

1. MATERIAL: Pipe shall be used which conforms to the requirements of ASTM B88. The pipe shall be of a Type K only and shall be dimensioned so as to allow the connection to AWWA standard water service taps and fittings. The pipe shall have surfaces smooth and free from bumps and irregularities.
2. PIPE JOINTS: All pipe joints on Copper pipe shall be soldered joints using ASTM B813, water flushable, lead-free alloy solder; and ASTM B828 procedure, or all brass compressive couplings with grip rings Ford C44 Pack Joint Coupling or approved equal unless otherwise specified.
3. SERVICE CONNECTIONS: The installation of service connections shall use only connections, equipment and practices recommended by the manufacturer. The service connection shall conform to the detail drawing shown in the standard drawings.

I. FITTINGS: Fittings shall be K-Copper or Cast Iron and have a pressure rating as may be required by the static pressure along the pipeline. All fittings shall be dimensioned according to ANSI A-21.10 or A-21-53 (AWWA C110 or C153) "American Standard for Cast Iron Fittings, 3 inches through 48 inches, for Water and other Liquids", and shall be equipped with restraining joints (mega-lug or equal).

J. TAPPING/REPAIR CLAMP MATERIAL SPECIFICATION:

1. SMALL TAPS/REPAIR CLAMPS: For small tappings and repair clamps (3/4" through 3") on cast iron, steel or ductile iron pipe, the following materials shall be required:

a. SADDLE CASTINGS: Small saddle tappings shall be similar to "Romac Stainless Steel Saddles" Model 202NS constructed of high tensile ductile (modular) iron, in accordance with ASTM specification 536-71, and shall be covered by a black nylon, plastic or epoxy fused coat, approximately 10-12 mils thick, with an approximate dielectric strength of 1000 volts per mill. The pressure rating of the tapping saddle shall equal the maximum static

pressure along the pipeline.

b. STAINLESS STEEL STRAP: Stainless steel straps shall consist of two two-inch wide straps to spread out the clamping force on the pipe and shall come complete with sufficient bolts, nuts and washers (with five-eighths-inch (5/8") N.C. Teflon coated roll threads) to properly clamp the strap to the pipe. M.I.G. welds shall be passivated for resistance to corrosion. The pressure rating of the tapping saddle shall equal the maximum static pressure along the pipeline.

c. GASKETS: Gaskets shall be made from virgin SBR compounded for water services.

2. LARGE TAPS/REPAIR CLAMPS: For large taps and repair clamps (larger than 3") on Cast Iron, Steel or ductile iron pipe, the following materials shall be required:

a. CUT IN TEE: The preferred method of making large taps or pipe repairs is to cut in a cement lined Ductile Iron tee with couplings and valves as specified in these Standards.

b. SLEEVES: Taps or pipe repairs can be made using sleeves that are either cast iron with an asphalt tar varnish coating or epoxy coated steel with stainless steel bolts Romac fabricated steel tapping sleeve Model FTS 420 or approved equal. No stainless steel sleeves will be allowed. All sleeves shall have a working pressure rating equal to the maximum static water pressure along the pipeline.

Tapping sleeve shall only be used when the tap is smaller than the pipe being tapped.

c. TAPPING VALVES: Tapping valves shall conform to Section 4.2.1.IV.G.1.

K. VALVES AND BOXES: All valves, ten inches (10") and smaller shall be of a resilient-seat-gate-valve type, and all valves over ten inches (10") shall be butterfly valves unless otherwise specified by the City Water Department.

1. GATE VALVES: Valves shall conform to the latest revision of AWWA Resilient Seated gate valve Standard C-509 and be UL listed, FM approved. All internal parts shall be accessible without removing the body from the line. The wedge shall be of cast iron

completely encapsulated with resilient material. The resilient sealing material shall be permanently bonded to the cast iron wedge with a rubber tearing bond to meet ASTM D 429. NRS stems shall be cast bronze or 18-8 Type 304 or 316 stainless steel with internal collars in compliance with AWWA. OS&Y stems shall be bronze. The NRS stuffing box shall have two "O"-Ring seals above the thrust collar. These rings shall be field replaceable without removing the valve from service.

There shall be low friction thrust bearings above and below the stem collar. The stem nut shall be independent of the wedge and of solid bronze. The waterway in the seat area shall be smooth, unobstructed and free of cavities. Stuffing box shall be attached to the bonnet and the bonnet to the body with bolts and nuts. All exposed bolts and nuts on the valve, not including flange bolts and nuts, shall be stainless steel. The body and bonnet shall be coated interior and exterior with corrosion resistant coating. Each valve shall be hydrostatically tested at 400 PSI to the requirements of both AWWA and UL/FM. Valve flange bolts and nuts shall be Zinc Coated Carbon Steel ASTM A307A Grade A.

Valves shall be installed vertically in a horizontal run of pipe, and shall be provided with a two-inch (2") square operating nut for manually operating the valve with a "T" handle wrench. The direction of rotation to open shall be to the left (counter-clockwise).

2. BUTTERFLY VALVES: All butterfly valves shall be of the tight-closing, rubber-seat type with rubber seats that are securely fastened to the valve body. No metal-to-metal seating surfaces shall be permitted. Valves shall be bubble-tight at rated pressures with flow in either direction, and shall be satisfactory for applications involving valve operation after a long period of inactivity. Valve discs shall rotate 90 degrees from the full open position to the tight shut position. Butterfly valves shall meet the full requirements of AWWA Standard C504 for Class 150B for areas with a static water pressures less than 150 psi without the use of pressure reducing valves, and Class 250B for all other areas. The manufacturer shall have manufactured tight-closing, rubber-seat butterfly valves for a period of at least five years. All valves shall be similar to those as manufactured by the Henry Pratt Company or approved equal.

Valve bodies shall be constructed of cast iron ASTM A-126 Class B (for flanged end valves) or ASTM A-48 Class 40 for wafer type valves. Flange drilling shall be in accordance with ANSI B16.1 Standard for cast iron flanges. Two (2) trunnions for shaft bearings shall be integral with each valve body. Body thickness shall be in

strict accordance with AWWA Standard C504. All exposed bolts and nuts on the valve, not including flange bolts and nuts, shall be stainless steel. Valve flange bolts and nuts shall be Zinc Coated Carbon Steel ASTM A307A Grade A.

Valve discs shall be constructed of alloy cast iron ASTM A436 Type I (Ni-Resist).

Shafts of all valves shall be turned, ground and polished. Valve shafts shall be constructed of 18-8 Type 304 or Type 316 stainless steel. Shaft diameters shall meet minimum requirements established by AWWA Standard 75 lbs. pull under test procedure ASTM D-429, Method B.

Valves shall be fitted with sleeve-type bearings. Bearings shall be corrosion resistant and self-lubricating. Bearing load shall not exceed one-fifth of the compressive strength of the bearing of shaft material. Packing shall be self-adjusting Chevron type. Valve operators shall conform to AWWA C504.

Manual operators shall be of the traveling nut, self-locking type and shall be designed to hold the valve in any intermediate position between fully open and fully closed without creeping or fluttering. Operators shall be equipped with mechanical stop-limiting devices to prevent over-travel of the disc in the open and closed positions. Valves shall close with a (clockwise) rotation. Operators shall be fully enclosed and designed to produce the specified torque with a maximum pull of 80 lbs. on the hand-wheel or chain-wheel. Operator components shall withstand an input of 450 Ft. Lbs. at extreme operator position without damage.

3. VALVE BOXES: All valves shall be provided with a Cast Iron valve box of the extension screw type, and the correct adjustable height to bring the top of the valve box flush with the ground surface. The valve box shall not be less than five inches (5") in diameter and shall have a minimum thickness of .375 inch. The box provided also shall be provided with a suitable base and cover. The word "WATER" shall be cast on the cover.

L. WATER SERVICE LATERALS: The material used for water service connections shall comply with the following:

1. SERVICE PIPE: Copper or PE service pipe shall be seamless and suitable for use as underground service connections and shall conform to Section 4.2.1.IV of these Standards.

2. CORPORATION STOPS: Corporation stops shall be similar to those manufactured by the Ford, shall be fitted with the proper adapter to the service line and shall conform to the several designations shown in the table below for the various sizes:

	WATER SERVICE CONNECTION SIZE					
	½"	¾"	1"	1½"	2"	3"
FORD	600	600	600	600	600	600

All services shall have a flare or compression type joint for the service pipe and threaded on the inlet end with an AWWA corporation stop thread. Gate valves with valve box shall be required on all water service connections greater than 1 inch.

3. METER SETTER YOKES: Meter setters or meter yokes shall be 18" high, Ford 70 series copper setter or equal, and shall have an AWWA approval, built-in back-flow device and inlet angle ball valve and grip joint compression couplings for copper tubing on both inlet and outlet. All internal parts shall be accessible without removing the setter from the line. Meters shall only be installed by City Water Department personnel.

4. METER BOX AND LID: The meter boxes shall be white, high density polyethylene ADS N-12 or equal, 18" X 36" (standard size). The meter lids shall be cast iron, auto read as shown in the Enoch City Engineering Details.

5. BUILDING SERVICE CONNECTIONS: At all points designated by the City Engineer, the owner shall install services for building connections, and shall extend such services to the property line, unless otherwise indicated by the City Water Department. Individual water services shall be 1 inch from the water main to the meter setter for normal domestic service, but may be one-and-one-half (1-1/2") or two-inches (2") in diameter as directed by the City Water Department. Services shall have a minimum of three feet (3') of cover and be laid as shown in the standard drawings.

M. FIRE HYDRANTS: Fire Hydrants shall be Mueller, Modern Centurion, Model A-423; Kennedy, Model K81A, or approved equal with 400 PSI test pressure, 200 PSI working pressure, 5 1/4" dia. 3 nozzle, foot valve and 6" mechanical joint connection. Fire hydrants shall conform to the latest edition of AWWA C-502, "Dry Barrel Fire Hydrants." All exposed bolts and nuts, not including flange bolts and nuts, on the fire

hydrant that are underground shall be stainless steel. Valve flange bolts and nuts shall be Zinc Coated Carbon Steel ASTM A307A Grade A. It shall be the responsibility of the Owner to furnish hydrants with a finish paint above the ground line identical to the existing hydrant paint (red). All exposed bolts and nuts that are below ground level on the fire hydrant shall be stainless steel.

V. FLOWABLE BACKFILL: Flowable backfill material shall conform to the following:

- A. Portland Cement - Type I or II Subsection 718.01.
- B. Fly Ash - ASTM C-618, Class F, except loss on ignition shall not exceed three percent (3%) maximum, and shall come from a source approved by the City Engineer.
- C. The coarse and fine aggregate for flowable fill shall be natural and consisting of mineral aggregate particles meeting the following:

<u>Sieve Size</u>	<u>Percent Passing</u>
3/4	100
200	0-10

- D. Mix Design (See Section 4.4 Concrete Work for Mix Design Submittal)- meet the following:

Minimum compressive strength (28 days)	50 PSI
Maximum compressive strength (28 days)	150 PSI
Minimum fly ash per cubic yard	300 lbs.
Maximum cement per cubic yard	50 lbs.
Maximum slump	10 in.

VI. PIPELINE CASINGS: Pipeline casings shall conform to the following:

- A. Casing Material – The casing material shall be smooth, uncoated carbon steel casing pipe with a minimum yield strength of 35,000 PSI and a minimum wall thickness of 0.375 inches.
- B. Casing Size – The casing size shall be sufficient to maintain a 2 inch minimum clearance between the greatest outside diameter of the carrier pipe (including pipe bells) and the minimum interior diameter of the casing pipe. Minimum clearance shall be maintained around the entire pipe circumference.
- C. Casing Chocks or Skids- Casing chocks or skids shall be Power Seal 4810 casing chocks or equal approved by the City Engineer. Casing chocks

or skids shall support the carrier pipe at a maximum of every 7 feet and install according to the manufactures directions.

D. Casing Seals- The annulus between the carrier pipe and casing on both v ends of the pipe casing shall be sealed with a neoprene boot and stainless steel straps provided by Power Seal or equal approved by the City Engineer.

E. Carrier Pipe Joints- The joints of the carrier pipe inside the case shall be joints that resist slipping by using either locking gaskets, glued or other non-slip type joints approved by the City Engineer.

VII. SPARE COMMUNICATION CONDUITS- A minimum of (1) one 2-inch gray, Schedule 40 PVC conduit with a nylon twin pull string with 500 pounds of pull strength shall be installed at least in one of the City sewer, storm drain or water line trenches required for any development.

4.2.2 CONSTRUCTION METHODS This section covers the requirements for trenching, placement, and back filling of all underground pipelines (sewer, water, storm drains, etc.). The methods employed in performing the work shall be the responsibility of the developer. The developer shall make such changes in the methods employed as are necessary to install an acceptable finished product. These methods shall include but are not limited to the following:

I. CONTROL OF GROUND WATER: All trenches shall be kept free from water during excavation, fine grading, pipe laying, jointing, and embedment operations. Where the trench bottom is mucky or otherwise unstable because of the presence of ground water, and in cases where the static ground water elevation is above the bottom of any trench or bell hole excavation, such ground water shall be lowered to the extent necessary to keep the trench free from water and the trench bottom stable when the work within the trench is in progress. Surface water shall be prevented from entering the trenches.

II. EXCAVATION FOR PIPELINES: Trench excavation shall include all operations necessary for excavation of all materials of whatever nature falling within the designated lines of the trenches. Trenches shall be excavated to the lines shown on the drawings or otherwise established by the City Engineer, and to a depth so as to provide a minimum burial of three feet (3') over the pipe unless otherwise specified. The bottom two feet (2') of the trench walls shall be vertical. All finish grade excavation necessary for preparation of the trench bottom shall be made manually. No over-excavating shall be allowed without re-compaction of backfill in accordance with these Standards.

Excavation for trenches in ledge rock, cobble rock, or stones shall extend to a depth of at least four inches (4") below the invert of the pipe. Bedding material as outlined in table 4.2 shall be placed and compacted to 95% of maximum dry density with pneumatic or vibratory tampers in six-inch (6") lifts to provide a

smooth, well compacted and stable foundation for the pipe or appurtenant works.

Trench bottoms shall be hand-shaped as specified and the maximum width of the trench, measured at the top of the pipe, shall be as narrow as possible, but not wider than 12 inches on each side of the pipe.

Where unstable earth, mud or muck is encountered in the excavation at the grade of the pipe, the unsuitable material shall be removed to a minimum of 12-inches below grade and the subsequent hole shall be backfilled with crushed rock or gravel (as called out in table 4.2 under "foundation material") to provide a stable subgrade. The gravel material shall be deposited over the entire trench width in a maximum of six-inch (6") thick layers. Each layer shall be compacted by tamping, rolling, vibrating, spading, slicing, rodding or by a combination of one or more of these methods. In addition, the material shall be graded to produce a uniform and continuous support for the entire length of the installed pipe. Where soil migration may be an issue, a filter fabric barrier may be required.

**TABLE 4.2
BACKFILL MATERIALS**

SIEVE SIZE	PERCENT PASSING FOR:			
	FOUNDATION MATERIAL*	BEDDING MATERIAL	PIPE ZONE MATERIAL	FINAL BACKFILL MATERIAL
2 inch	100	---	---	Native material which contains no sod, vegetation, rocks larger than 8" in diameter, asphalt or concrete chunks, etc.
3/4 inch	0 - 50	100	100	
No. 4	0 - 10	---	40 - 70	
No. 50	0 - 5	---	20 - 50	
No. 200	0 - 3	0 - 15	5 - 30	

*To be used only when the trench bottom is unstable.

(The standard drawings show the typical trench backfill details.)

III. SHEETING, BRACING AND SHORING OF EXCAVATIONS: All excavations shall be sheeted, braced, and shored as required to protect the workers and

existing utilities and improvements from sliding, sloughing or settling of the trench walls while the work is in progress. All such sheeting, bracing and shoring shall comply with the requirements of the Utah State Industrial Commission. All damage resulting from lack of adequate sheeting, bracing and shoring shall be the responsibility of the Contractor, and the Contractor shall effect all necessary repairs or reconstruction resulting from such damage.

IV. BLASTING: Blasting will not be allowed except by written permit from the Enoch City Fire Chief. If the permit is granted, the Contractor shall comply with all laws, ordinances, and applicable safety code requirements and regulations relative to the handling, storage, and use of explosives and protection of life and property.

The contractor shall comply with the provisions outlined in the U.S. Bureau of Mines Bulletin No. 656 "Blasting Vibrations and their Effects on Structures", and other applicable ordinances as specified by the Fire Chief.

The contractor shall be fully responsible for all damage attributable to such blasting operations. Excessive blasting or overshooting will not be permitted and any material outside the authorized cross-section, which may be shattered or loosened by blasting, shall be removed and properly replaced.

V. PIPE LAYING AND BEDDING: Pipe will be carefully inspected in the field by City Inspectors before and after laying. If any cause for rejection is discovered in a pipe after it has been laid, it shall be removed and replaced by the Contractor.

When connections are to be made to any existing pipe, conduit, or other appurtenances, the actual elevation or position of which cannot be determined without excavation, the Contractor shall excavate for, and expose the existing improvement before laying any pipe or conduit. The City Inspector shall be given the opportunity to inspect the existing pipe or conduit before the connection is made. Any adjustments in line or grade that may be necessary to accomplish the intent of the plans will be made.

Pipe shall be laid up grade with the socket or collar ends of the pipe up grade unless otherwise authorized by the City Water Department and/or City Engineer.

Pipe shall be laid true to line and grade, with uniform bearing under the full length of the barrel of the pipe. Suitable excavation shall be made to receive the bell or collar, which shall not bear upon the subgrade or bearing. Any pipe, which is not true to alignment or shows any settlement after laying, shall be removed and re-laid to the proper grade and alignment. Wherever possible, sanitary sewers shall be installed on the down-hill side of the street.

A. REQUIREMENTS FOR LINE AND GRADE: All sewer and drainage pipe shall be installed using a pipe grade and alignment laser system. The

line and grade shall be within the following limits:

1. Variance from established line and grade shall be not greater than one thirty-second ($1/32$) of an inch per inch of pipe diameter.
2. The total variance from line and grade shall not exceed one-half ($1/2$) inch, provided that such variation does not result in a level or reverse sloping invert.
3. The variation in the invert elevation between adjoining ends of pipe, due to non-concentricity of joining surface and pipe interior surfaces, shall not exceed one sixty-fourth ($1/64$) of an inch per inch of pipe diameter.
4. The total non-concentricity variance shall not exceed one-half ($1/2$) inch maximum.

B. INSTALLATION OF PIPE. Bell holes shall be excavated so that only the barrel of the pipe receives bearing from the trench bottom. Large rocks (over 6 inches in least dimension) near the surface shall be removed and the hole refilled with approved backfill in accordance with table 4.2.

Sewer and drain pipe shall be laid up grade. All pipe installation shall proceed with joints closely and accurately fitted. Gaskets shall be fitted properly in place and care shall be taken in joining the units to avoid twisting the gaskets. Joints shall be clean and dry and a joint lubricant, as recommended by the pipe supplier, shall be applied uniformly to the mating joint surfaces to facilitate easy and positive joint closures. If adjustments to the position of a pipe length is required after being laid, the pipe shall be removed and rejoined as for a new pipe. When laying is not in progress, the ends of the pipe shall be closed with a tight-fitting stopper to prevent the entrance of foreign material. In addition to the above requirements, all pipe installation shall comply with the specified requirements of the pipe manufacturer.

C. SETTING OF BENDS, TEES, CROSSES AND REDUCERS: Bends, tees, crosses, and reducers shall be lowered into the trench, inspected, cleaned and joined to the pipe.

Reaction or thrust blocking shall be applied at bends and tees, and at points of reducing or in fittings where changes in pipe diameter occur. The design of concrete thrust blocking shall be as shown in the Standard drawings or as directed by the City Water Department. The material for reaction or thrust blocking shall be Class C in accordance with Table 4.10 and Section

4.4 of these standards. Blocking shall be placed between solid ground and the fitting to be anchored. The area of bearing on the fitting and on the ground shall in each instance be that required in the drawings or by the City Engineer. Unless otherwise directed by the City Engineer, the blocking shall be placed so that the pipe and fitting joints will be accessible for repair in accordance with the Standard Drawings. Restraining joints (mega-lug or equal) shall also be used to prevent movement wherever thrust blocks are required.

D. PLUGGING OF DEAD-ENDS: Standard plugs shall be inserted into the bells of all dead-end fittings. Spigot ends of fittings and plain ends of pipe shall be capped. A concrete reaction or thrust block shall be provided at all plugged outlet fittings in the sizes indicated on the standard drawings or as directed by the City Engineer. They also shall be tied to the pipe with restraining joints.

E. SERVICE LINES:

1. All new water and sewer service lines shall be installed according to the details shown on the Standard Drawings.
2. When a new water or sewer service line is installed all abandoned water and sewer lines shall be cut and capped within 1 foot of the main as directed by the water or sewer collections supervisor.

F. PIPE TO BE KEPT CLEAN: All foreign matter or dirt shall be removed from the interior of the pipe before lowering into position in the trench. Pipe shall be kept clean by means approved by the City Engineer during and after laying.

G. JOINTING PIPE SECTIONS: The sealing surface of the pipe, the bell to be joined, and the elastomeric gaskets shall be cleaned immediately prior to assembly, and assembly shall be made as recommended by the manufacturer. When pipe laying is not in progress, the open ends of installed pipe shall be closed to prevent entrance of trench water into the line. Whenever water is excluded from the interior of the pipe, enough backfill shall be placed on the pipe to prevent floating. Any pipe that has floated shall be removed from the trench and the bedding restored. No pipe shall be laid when the trench conditions or the weather are unsuitable for proper installations as determined by the City Engineer.

H. CUTTING PIPE: The pipe shall be cut in a neat manner without damage to the pipe so as to produce a smooth end at right angles to the axis of the pipe.

I. END PREPARATION: Pipe ends shall be cut square, deburred and

beveled in accordance with the pipe manufacturer's recommendations.

J. PUSH-ON JOINTS: The push-on joint shall be a single elastomeric gasketed joint that shall be assembled by positioning the elastomeric gasket in the annular groove of the bell and inserting the spigot end of the pipe into the bell. The spigot end of the pipe shall compress the gasket radially to form a positive seal. The gasket and annular groove shall be designed, sized and shaped so that the gasket will resist displacement. Care shall be taken so that only the correct elastomeric gasket, compatible with the annular groove of the bell, is used. Insertion of the elastomeric gasket in the annular groove of the bell must be in accordance with the manufacturer's recommendations.

Joint Gap tolerances for concrete pipe shall be as follows:

Inner Diameter of Pipe	Maximum Joint Gap Tolerance	Maximum Joint Gap Tolerance(with Grouting)
12" to 36"	5/8"	3/4"
42" to 48"	7/8"	1-1/8"
54" to 90"	1.0"	1-1/4"
96"	1-5/8"	1-3/4"
Sizes above 96" up to 144"	As recommended by Manufacturer	As recommended by Manufacturer

K. MECHANICAL JOINTS: The mechanical joint shall be a bolted joint of the stuffing box type, and installation recommendations from the manufacturer shall be followed. Each joint shall consist of:

1. A bell provided with an exterior gland having bolt holes or slots and a socket with an annular recess for the sealing gasket and the spigot end of the pipe.
2. A sealing gasket.
3. A follower gland with bolt holes matching those in the fitting.
4. Tee bolts and hexagonal nuts of cor-ten metal.

L. METER BOXES: All meter boxes shall be located behind the sidewalk, in the center of the lot. Any meter box covered or damaged during the construction operations shall be replaced or uncovered and raised to finish grade by the Contractor. The meter box shall be surrounded by a concrete apron as shown in the standard drawings.

M. PIPE BEDDING. Pipe shall be protected from lateral displacement and possible damage resulting from impact or unbalanced loading during backfilling operations by being adequately bedded in accordance with the bedding details in the standard drawings.

Pipe bedding materials shall be deposited and compacted in layers not to exceed six inches in compacted thickness. Deposition and compaction of bedding materials shall be done simultaneously and uniformly on both sides of the pipe. Compaction shall be accomplished with hand or mechanical compactors. All bedding materials shall be placed in the trench with hand tools or other approved methods in such a manner that the bedding materials will be scattered alongside the pipe and not dropped into the trench in compact masses. Bedding materials shall conform to the requirements of table 4.2 of these standards and shall be free from roots, sod, or other vegetation.

In the event trench materials are not satisfactory for pipe bedding, imported bedding will be required. Imported bedding shall consist of placing compacted granular material on each side of and to the level of twelve inches above the top of the pipe. Imported bedding material shall be graded in accordance with table 4.2, under "bedding material".

VI. BACKFILLING AND COMPACTION: Backfill shall be carefully placed around and over pipes and shall not be permitted to fall directly on a pipe from such a height, or in such a manner as to cause damage. Backfill material shall be as required by table 4.2 or as approved by the City Engineer and shall not contain any wood, grass, roots, broken concrete, frozen soil, asphalt chunks, trash or debris of any kind that may cause unequal settlement or improper consolidation.

The backfill in all utility trenches under proposed or existing roadways, curb and gutter, sidewalks and driveways shall be compacted to the equivalent of 95% of maximum dry density for granular soils or 90% of maximum dry density for silty/clay soils as classified by AASHTO M-145 Soil Classification System. In shoulders and other street right-of-way areas, the in-place density shall be a minimum of 90% of the maximum dry density.

A. INITIAL BACKFILL PROCEDURE. Backfill of selected material, which shall conform to the requirements of table 4.2, shall be placed carefully in eight-inch non-compacted horizontal layers and tamped to a depth of 8 to 12 inches over the top of the pipe. During compaction of the initial backfill, special care shall be taken so as to not move the pipe, either vertically or horizontally and that the pipe haunches are properly hand compacted to the required density. All backfill operations shall be performed in such a manner so as to avoid any damage to the pipe, valves, laterals, etc. In the event such damage or displacement occurs, such

damaged or displaced pipe shall be removed and replaced with undamaged pipe on proper grade and alignment.

B. FINAL BACKFILL PROCEDURE. The backfill above a point 8 to 12 inches above the top of the pipe shall be backfilled in horizontal layers 12 inches thick or less with materials containing no brush, perishable or objectionable material, or rocks, stones or boulders larger than 8-inches in the greatest dimension. The material shall be mechanically compacted with appropriate vibrating compaction equipment.

C. MECHANICAL COMPACTION OF BACKFILL. The backfill shall be thoroughly compacted by consolidation or mechanical compaction.

Structural and trench backfill shall be deposited in horizontal layers and compacted by the following method in such manner that the compacted material will be homogeneous and free from lenses, pockets, streaks, and other imperfections.

The materials shall be deposited in horizontal layers (across the length or width of the excavation of not more than six inches compacted thickness. The excavation and placing operations shall be such that the materials when compacted will be blended sufficiently to secure the best practicable degree of compaction, impermeability and stability. Care should be taken that the compaction process does not push the pipe off line or grade.

Prior to and during compaction operations, all backfill material shall have the optimum practicable moisture content and shall be uniform throughout each layer.

Moisturizing of the materials shall be performed at the site of excavation. If the moisture content is not optimum for compaction, the compaction operations shall be delayed until such time that the material has been brought the optimum moisture content. When the material has been properly conditioned, it shall be compacted by using appropriate mechanical compaction equipment as indicated below. The compaction equipment shall not come in contact with the pipe.

1. Vibrating Rollers shall consist of a self-propelled roller with a vibrating steel drum of at least one-ton capacity. The roller shall have an effective rolling width of at least 24 inches and shall deliver a compaction force of at least 700 pounds per square inch when vibrating.

2. Pneumatic rollers shall consist of a self-propelled roller with pneumatic tires arranged in a manner so as to provide a satisfactory

compacting unit. The roller shall have an effective rolling width of at least 30 inches and shall give a compaction force of at least 500 pounds per inch of width of tread when fully loaded. The tires shall be uniformly inflated.

3. Vibrating plates shall consist of a pneumatic vibrating plate attached to the boom of a backhoe and capable of compacting an area of at least three square feet. The plate and backhoe combination shall together be capable of exerting a compactive force of at least 1,000 pounds per square inch.

4. Hand Compactors shall be used when hand-compacted methods are specified or required because the location of the area to be compacted does not permit the use of self-propelled mechanical compactors. Vibrating plates, "pogo-stick" tampers or other approved hand-compacting equipment shall be used.

5. Jetting and Flooding methods are not permitted.

D. FLOWABLE BACKFILLING: In the pavement or sidewalk, curb and gutter sections on all existing City streets and State highways, flowable fill shall be used (unless otherwise approved by the City Engineer) for backfill and shall be in conformance with the standards of "Flowable Fill" as described herein. Flowable fill shall be discharged from the ready mix truck by any reasonable means into the trench to be filled. The fill will be brought up to the bottom of the surface course and shall be finished to provide a uniform surface. Care should be taken to prevent the flotation of any pipe.

VII. TRENCHES ON HIGHWAYS AND STREETS: Wherever trenches will be in, or must cross State highways or streets, the contractor shall obtain such excavation permits as are required for these crossings and shall become familiar with and abide by the rules and directions of the Utah Department of Transportation while working in these streets.

All contractors excavating in any Enoch City public right-of-way shall obtain a Road Breaking Permit in compliance with the Enoch City street ordinance prior to excavating.

All asphalt cuts shall be made with a diamond or carbide-tipped masonry or asphalt cutting saw or with a steel asphalt-cutting wheel attached to a grader or back-hoe. No scarifier-tooth cuts, back-hoe, bucket rips, or jackhammer spade cuts will be allowed.

All backfilled trenches in roadways shall be patched with hot-mix asphalt within fourteen days of initial excavation unless otherwise directed by the City Engineer.

The backfill section shall be according to the typical road sections of these standards.

All concrete or asphalt surfaces damaged or cut in trenching operations shall be restored to an as-good or better condition than prior to excavation in accordance with the provisions outlined in section 4.3 of these standards.

During the entire trenching, backfilling and patching operations, the Contractor will be required to observe all safety and traffic control procedures as outlined in these standards and City Ordinance Chapter 31.

The contractor shall be responsible for maintenance of the trench and patch for a period of 18 months from the date of the completion of the patching operation.

Unless otherwise approved by the City Engineer, not more than 400 feet of trench shall be left unfilled at any time in one continuous run.

All streets and roads trenched shall be kept free from dust and open to through traffic unless permission to close the street is obtained by the Contractor from the City Engineer. Up to one-half the width of any street or road shall be temporarily restored for use before excavation is commenced on the remaining portion of the street or road. All excavation, backfilling and temporary resurfacing on any portion of any street or road shall comply with the City Street Ordinance Chapter 31 and these standards.

VIII. CLEANING OF SANITARY SEWER LINES: After all sewer lines have been laid and the trench backfilled, the sewer lines shall be thoroughly cleaned prior to acceptance by the City.

Cleaning shall be accomplished by introducing sufficient water at the upper end of the trunks and laterals to flush the lines completely clean of all foreign material. No debris shall be permitted to enter any sewer lines in service. All debris shall be removed at the lowest manhole of the extension. Other methods of cleaning may be used, subject to approval by the City Engineer. After the lines have been thoroughly cleaned, they shall be tested between each manhole for displacement.

IX. CLEANING AND DISINFECTION OF WATER SYSTEMS: Each line, after being tested and before being placed in service, shall be disinfected by chlorination in accordance with AWWA standard C651-05. Prior to chlorination the entire line shall be flushed to insure that all dirt or foreign objects have been removed from the line. The line used to flush the line shall be six-inch minimum and no fire hydrants shall be used for flushing.

New water mains and extensions of existing mains shall be disinfected in accordance with AWWA standard C651-99. Sufficient chlorine shall be added to insure a residual of twenty-five parts per million in the water after twenty-four hours standing in the pipe. Chlorine calcium hypochlorite dry chlorinating

chemical solution, containing approximately 65% available chlorine by weight, shall be used for this purpose. Calcium hypochlorite that is intended for swimming pool disinfection will not be allowed. The preferred method of disinfecting new water lines shall be continuous feed. Other methods within this standard may be allowed with permission and supervision of the process by the City.

Following chlorination, all treated water shall be drained and the pipeline thoroughly flushed with clean water. The entire line shall be flushed after the specified contact period, and such flushing shall be continued until the water is free from excess chlorine. The entire line, including hydrant laterals, branch lines, and dead-end mains shall be flushed. Chlorine residual must be tested after final flushing by the City Water Department. The discharge of flushed water shall be accomplished in such a manner that no erosion will occur and with no damage to streets or other property. Procedures for discharge will be subject to the review of the City Engineer and City Water Department.

X. SPARE CONDUIT LAYING, BEDDING AND BACKFILLING: Spare conduits shall be installed according to the typical utility trench detail.

4.2.3 QUALITY CONTROL. All underground pipelines shall be installed in accordance with these standards and tested as outlined below.

I. TRENCH BACKFILL MOISTURE/DENSITY TESTING.

Soil Proctor	One determination for each significant change in soil type as necessary to provide required compaction testing. Tests shall be ASTM D1557 Method A or D (modified proctor).
--------------	---

Trench backfill moisture/ density determination -	Tests are required for trench backfill for every 200 lineal feet of trench including service lateral trenches), or other utility trench or portion thereof, and each manhole, valve or set of valves within a 10-foot diameter that comes to the surface in the street section. Tests shall be run at the following trench elevations:
--	--

One test at top of pipe zone.

One test per 2 feet of depth measured from the bottom of the subgrade to the top of the pipe zone. Tests shall be evenly spaced vertically through the trench with one test at top of trench (bottom of subgrade).

Additional testing may be required by the City Engineer or soils testing lab to verify compaction.

Tests shall be according to ASTM D1556 or D2922 and D3017.

II. SANITARY SEWER LINE TEST AND ACCEPTANCE. This section specifies requirements for determining the acceptability of sewer systems after all sewer lines have been cleaned. The sewer lines, service laterals and manholes shall be tested for leakage and alignment in the presence of the City Engineer as outlined below. Where directed by the City Engineer and prior to acceptance by the City, the Contractor may be required to conduct and successfully pass a TV pipe inspection. Testing shall only be completed after installation of main lines, branch lines, and manholes. When indicated, below parts of this section shall also apply to storm drain systems.

A. DISPLACEMENT TEST. The displacement test shall be conducted by the Contractor in accordance with the following procedure:

A light shall be flashed between manholes or, if the manholes have not as yet been constructed, between the locations of the manholes, by means of a flashlight or by reflecting sunlight with a mirror. If the illuminated interior of the sewer or storm drain pipe shows broken, misaligned or displaced pipe, or other defects, the defects designated by the City Engineer shall be remedied by the Contractor. After cleaning and inspection have been completed, the sewer line shall be tested for leakage.

B. AIR TESTING. Each reach of sewer pipe to be tested shall be isolated by completely blocking all outlets in the section under test. Careful attention shall be given to blocking all plugs. Prior to installing the lower and upper plugs, concrete pipe and manholes shall be wetted to minimize any loss of air through the pipe or manhole walls as a result of permeability in the dry condition. One of the plugs used at the manhole must be equipped to control the air entry rate and to prevent the pressure from exceeding five p.s.i.g., this shall be done by means of a blow-off valve set to operate a five p.s.i.g.

After the concrete pipe has been wetted and plugs installed, the air shall be allowed to slowly fill the pipe until a constant pressure of 4.0 p.s.i.g. is maintained for at least two minutes. During the two-minute stabilization period, all plugs and exposed fittings shall be checked with a soap solution. If a leak is found, the air shall be bled off, the leak repaired and a new two-minute stabilization period begun. When the temperature of the air has reached equilibrium with that of the pipe wall, the air pressure shall be brought to 4 p.s.i.g. and the supply shall then be disconnected. When the

pressure gauge reaches 3.5 p.s.i.g., a stop watch shall be started and then stopped when the pressure reaches 2.5 p.s.i.g. The time required as shown on the watch for a loss of 1 p.s.i.g. at an average pressure of 3.0 p.s.i.g. is used to calculate the rate of air loss. The pipeline may be considered to have passed the air loss test successfully if the loss of air is not greater than a rate of 0.0030 cubic feet per minute per square foot of internal pipe surface. The following table shows the allowable time for the pressure to drop from 3.5 to 2.5 p.s.i.g. for respective pipe diameters.

Pipe Diameter	Time		Pipe Diameter	Time	
	Min.	Sec.		Min.	Sec.
6-inch	3	0	18-inch	8	30
8-inch	3	45	20-inch	9	30
10-inch	4	45	21-inch	10	0
12-inch	5	45	24-inch	11	15
14-inch	6	30	27-inch	12	45
15-inch	7	0	30-inch	14	0
16-inch	7	30	36-inch	17	0

C. EXFILTRATION TEST. In lieu of the standard sanitary sewer air test, the Contractor may make an exfiltration test in accordance with the following procedure:

The test section shall be blocked at both ends and the pipe subjected to a hydrostatic pressure produced by a head of water at a depth of three feet above the invert of the sewer at the upper manhole under test. In areas where ground water exists, the head of water shall be three feet above the existing water table.

For concrete pipe, the three-foot head of water shall be maintained for a period of one hour to obtain full absorption of the pipe body and thereafter for a further period of one hour for the actual test leakage. For all other types of pipe, the three-foot head of water shall be maintained for a period of one hour only. During the one-hour test period the measured maximum allowable rate of ex-filtration for any section of sewer, including service stubs, shall be as listed below:

SEWER MAIN DIAMETER (inches)	MAXIMUM DROP IN HEAD IN A 4-FT. DIAMETER MANHOLE (Non-taper sect.) per 100 ft. of sewer pipe	MAXIMUM ALLOWABLE EXFILTRATION (Gallons/Hour/100 ft.)

6	0.1563 inch	1.2
8	0.2031 inch	1.6
10	0.2500 inch	2.0
12	0.3125 inch	2.4
15	0.3594 inch	2.8
18	0.4063 inch	3.2
21	0.4531 inch	3.6
21 or larger	0.5156 inch	4.0

In case measurements indicate an exfiltration greater than the maximum allowable leakage, additional measurements shall be taken and continued until all leaks are located and the necessary repairs and corrective work have reduced the leakage in the section being tested below the maximum allowable by these standards. For purposes of the test, the line between adjoining manholes will be considered a section and will be tested as such.

The Contractor shall furnish the plugs and other material and labor for placing the plugs in the sewer and shall assist the City Engineer in making all measurements required. The introduction of any substance into the water used for testing with the intent of sealing such leaks as may be indicated will not be permitted.

If results of either the air test or the exfiltration test is not satisfactory, repairs or pipe replacement shall be required until the City Engineer is satisfied that the leakage requirements are being met. All repair methods and materials used must be accepted by the City Engineer.

D. PVC AND HDPE DEFLECTION TEST. All PVC sanitary sewer pipe and when required by the City Engineer, PVC and HDPE storm drain pipe, shall be mandrelled with a rigid device sized to pass through the pipe with five-percent or less deflection of the pipe. These allowances shall include deformations due to all causes (wall thickness variations, shipping, production, backfill, heat, etc.). The mandrel device shall be cylindrical in shape and shall comply with the manufacturer's recommendations.

The mandrel shall be hand pulled by the contractor through all sewer lines. Any sections of sewer not passing the mandrel shall be uncovered and the contractor shall re-round or replace the sewer to the satisfaction of the City Engineer and all repaired sections shall be re-tested.

The deflection test shall be conducted after reaching final trench backfill grade and compaction.

E. INSPECTION AND FLUSHING. Prior to final acceptance of each section of sanitary sewer line, the Contractor shall flush all sewer lines. All lines shall be video inspected immediately following the flushing or when water has been run through the line. A video shall be made of all lines. All dirt and debris shall be prevented from entering the existing sewer system by means of water-tight plugs or other suitable methods.

Upon completion of the project, the City Engineer will carefully inspect all sewers and appurtenances. Any unsatisfactory work shall be removed and replaced in a proper manner. The invert of the sewer and manholes shall be left smooth, clean, and free from any obstructions throughout the entire line. All manhole rings and covers shall be adjusted to finished grade and concrete collars installed prior to acceptance of the sewer system.

F. MANHOLE LEAKAGE TEST: Sewer manholes shall be tested for leakage prior to acceptance if they are located in areas of probable flooding or high water table, or if their tightness is suspect, as determined by the City Engineer. Allowable leakage shall be one gallon per hour per manhole. At least two manholes shall be tested, and based on these test and visual inspection of all manholes, additional tests may be required for other manholes. Any manhole, which tests unsatisfactorily, shall be repaired and retested until satisfactory results are obtained.

G. TELEVISION TESTING: When required by the City Engineer the Contractor or his representative (a qualified firm or individual agreed upon by the City Engineer and the Contractor) shall furnish labor, equipment, and materials, including camera and video tapes, and shall perform, in the presence of a City Representative, an internal television test of the completed sewer or storm drain pipe before it can be placed in service. Prior to the internal television test, the line being tested shall be flushed with clean water and allowed to free drain. The residual water shall not be removed in any way prior to the test. If all of the flushing water is removed, an amount of water shall be introduced into the farthest upstream manhole and will be allowed to flow through the newly installed pipes to expose potential low spots or “bellies”. The contractor shall supply the City with a copy of the video tape. The television test shall be subject to the City Engineer’s approval. Any defects in the pipe or the pipe installation noted on the internal TV inspection shall be corrected by the contractor and the repaired section shall be TV inspected after the repair to verify that the defective section has been corrected.

III. WATER SYSTEM TESTING AND ACCEPTANCE: The Owner and/or Contractor shall disinfect and test all water mains prior to final acceptance by the City. This shall include the owner repairing any existing parts of the City water system that must be included in the test but are not capable of holding test pressures. Or, as an alternative, testing the new water system before connecting it to

the existing water system and having the City visually test the City approved connection of the systems. All concrete reaction blocks shall be in place at least five days before the initial filling of the line, unless high early strength concrete is used which will require three days in place.

A. PRESSURE TEST: After the pipe has been laid, including fittings, valves, corporation stops, services, and hydrants, and the line has been backfilled in accordance with these standards, each valved section, unless otherwise directed by the City Water Department, shall be subjected to hydrostatic pressure of not less than 200 pounds per square inch. The duration of each such test shall be two hours. Water added to maintain the pressure shall not exceed 0.4 gallons per inch diameter per 1000 lineal feet of main being tested during the two-hour test period.

Each valved section of pipe shall be slowly filled with water, and the specified test pressure measured at the lowest point of elevation. This shall be applied by means of a pump connected to the pipe in a satisfactory manner. The pump, pipe connection, gauges, pipe caps and couplings, and all necessary apparatus shall be furnished by the Owner. Gauges and measuring devices must meet with the acceptance of the Water Department and the necessary pipe taps shall be made as directed. Before applying the specified test pressure, all air shall be expelled from the pipe by drilling small holes at points of highest elevations and afterward tightly plugging those holes with brass plugs.

Any cracked or defective pipes, fittings, valves, or hydrants discovered in the pressure test shall be removed and replaced with sound material in the manner provided. The test shall be repeated until the water main passes the pressure test and is accepted by the City Water Department or City Engineer.

B. OPERATIONAL INSPECTION: At the completion of the project and in the presence of the City Engineer, the Owner shall operate all valves, hydrants, and water services to ascertain that the entire facility is in good working order; that all valve boxes are centered and valves are operational; that all hydrants operate and drain properly and that water is available at all meter boxes.

IV. SPARE CONDUIT TESTING AND ACCEPTANCE: Spare conduits shall be accepted if the required nylon twine pull string with 500 pounds of pull strength can be blown through the conduit by attaching a plug to the pull string that fits tightly in the conduit and blowing the plug through the conduit with air pressure.

4.3 ROADWAY CONSTRUCTION This section covers the requirements for construction of roadway pavements including base course, bituminous prime coat, bituminous surface course, bituminous seal coat and street signs. Pavement structure shall comply with Table 4.3 unless required engineering and geotechnical studies

support another preferable design.

**TABLE 4.3
ROAD CROSS-SECTION STANDARDS**

	TYPE OF ROAD	
	LOCAL AND COLLECTOR	MAJOR COLLECTOR AND ARTERIAL
ASPHALTIC CONCRETE	2"	2.5"
GRAVEL (ROADBASE)	8"	10"
TOTAL SECTION THICKNESS	10"	12.5"

4.3.1 MATERIALS: Roadway construction materials in City improvements shall conform to the following:

I. BASE COURSE MATERIAL: Base for all streets shall consist of select material, either pit run or road base. Prior to placing untreated base course, the Contractor shall submit, in writing, a job-mix gradation to the City Engineer for approval. The job-mix gradation shall have definite single values for the percentage of aggregate sizes.

A. PIT RUN: Pit run materials shall be deposited, spread and compacted on the scarified and compacted nature soil. The material used for Pit Run in all streets shall conform to the following:

1. Pit run shall consist of hard tough, and sound mineral aggregates that consist of native gravel free of deleterious and/or organic materials.
2. The gradation for the pit run material shall meet the gradation shown in Table 4.4.

**TABLE 4.4
PIT RUN GRADATION**

SIEVE SIZE	PERCENT PASSING (PIT RUN)
3"	100
2"	90-100

1"	70-90
3/4"	--
1/2"	50-75
3/8"	--
#4	30-65
#16	15-40
#50	--
#200	2-15

B. ROAD BASE MATERIAL: Road base material shall be deposited, spread and compacted on the finished Pit Run or scarified and compacted native soil as required. The supplier shall submit certification from a materials testing firm to the City Engineer for approval prior to the commencement of each construction season showing that the material used for Road Base conforms to the following:

1. Road base for all streets shall consist of clean, hard, tough, durable and sound mineral aggregates that consist of crushed stone, crushed gravel, or crushed slag; free of deleterious and/or organic materials.
2. Dry-rodded unit weight shall be at least 75 pounds per cubic foot.
3. Material shall meet fractured face minimum of 25% under UDOT 8-929, for material retained on the number 4 sieve and above.
4. Material-passing the number 40 sieve shall be non-plastic.
5. Aggregate wear under ASTM-C-131 or AASHTO T-96 shall be less than 50%.
6. The "Job Mix Target" gradation of the aggregate shall fall within the band limits shown on Table 4.5.

**TABLE 4.5
ROAD BASE GRADATION**

SIEVE SIZE	PERCENT PASSING OF TOTAL AGGREGATE (DRY WEIGHT)		
	1-Inch	3/4- Inch	1 ½ - Inch
1 ½ Inch	100	100	100
1 INCH	100	-	81-100
3/4 INCH	-	100	61-94
1/2 INCH	68-99	-	56-89
3/8 INCH	-	68-99	46-84
No. 4	40-70	46-76	33-72
No. 16	20-42	21-45	20-45
No. 200	4-14	4-14	4-14

II. BITUMINOUS PRIME COAT MATERIAL: The bituminous prime coat shall consist of an application of hot bituminous material on a previously prepared surface course. When required, bituminous material for the prime coat shall be MC-70.

III. BITUMINOUS SURFACE COURSE MATERIAL: Over the cured prime coat when required or over the prepared base course, the Contractor shall place and compact a bituminous surface course. The surface course shall consist of a mixture of materials of mineral aggregate and asphaltic cement. The bituminous surface course material supplier shall submit a mix design to the City Engineer for approval prior to the commencement of each construction season or upon selection of new aggregate sources.

A. AGGREGATE: The design mix gradation shall meet the specified gradations shown in Table 4.6 unless other job-mix designs are submitted and approved by the City Engineer prior to laying and conform to Table 4.9 of these Standards. The crushed aggregate shall have a weighted percent of loss not exceeding 10 percent by weight when subjected to five cycles of sodium sulfate and tested in accordance with AASHTO Designation T-104.

**TABLE 4.6
BITUMINOUS SURFACE COURSE
AGGREGATE GRADATION**

SIEVE SIZE	GRADATION LIMITS Percent Passing of Total Aggregate (Dry Weight)		
	¾ inch Material	½ inch Material	3/8 inch Material (skin patches only)
1 Inch	-	-	-
¾ Inch	100	-	-
½ Inch	-	100	-
3/8 Inch	70-95	-	100
No. 4	43-66	55-86	70-90
No. 8	-	-	45-70
No. 16	20-37	25-45	25-50
No. 50	10-25	10-25	10-25
No. 200	4-9	4-10	5-15

B. ASPHALTIC CEMENT MATERIAL: The asphaltic cement material shall be either AC-20 (AR-8000), AC-10 (AR-4000) or a performance grade asphalt binder (PGAB) PG 64-22 or PG 64-28 in accordance with the Asphalt-Institute specifications unless otherwise specified by the City Engineer. The percentage of asphaltic cement material or PGAB for ¾ and ½ inch aggregate material shall be according to the approved design mix. This percentage can deviate by 0.3% from the target. The percentage of Asphaltic Cement material or PGAB for 3/8 inch skin patch aggregate material shall be 6%. This percentage can deviate by 0.5% from the 6%.

C. RECLAIMED ASPHALT PAVEMENT (RAP): A maximum of 15% of RAP as a percent by weight of RAP to the total weight of the mix will be allowed for bituminous surface course material.

IV. BITUMINOUS SEAL COAT MATERIAL: (ASPHALT EMULSION/FLUSH COAT) Bituminous surface treatment (Flush Coat) shall be applied to the road surface of all new streets and other existing streets when required by the City Engineer. The bituminous surface treatment shall consist of an application of asphalt emulsion over the bituminous surface course. The materials used in the application of the bituminous surface treatment shall be asphalt emulsion and blotter sand when required. The materials for this seal coat are as follows:

A. ASPHALT EMULSION: The asphalt emulsion shall conform to the specifications outlined in Table 4.7.

B. BLOTTER SAND shall consist of pit reject sand with no particle larger than 1/8 inch.

TABLE 4.7

ASPHALT EMULSION TEST SPECIFICATIONS

T E S T S O N E M U L S I O N S				
TESTS	TEST METHOD		TYPE OF EMULSION	
	AASHTO	ASTM	ANIONIC	CATIONIC
			QUICK SETTING	QUICK SETTING
			CQS-H	CQS-KH
Dilution Rate: Part Oil: Part Water			2:1	2:1
PARTICLE CHARGE TEST	--	D244, 18-20	NEGATIVE	POSITIVE
FUROL VISCOSITY, 60 ml., @ 77 Deg. f., 5 Seconds	T59, 2b1	D88	15 to 50	
RESIDUE BY EVAPORATION	T59, 2a3	D244, 13-17	60 Percent by weight, minimum	
SETTLEMENT AFTER FIVE DAYS	T59, 2c2	D244, 28-31	3 Percent maximum	
SIEVE TEST	T59, 2c4	D244, 37-40	0.10 Percent maximum	-----
SIEVE TEST	-----	D2397 4.1.2	_____	0.10 % max.
CEMENT MIXING TEST	T59, 203	D244, 32-36	2% Maximum	Not Applicable

V. BITUMINOUS SEAL COAT MATERIALS: (CHIP SEAL)

Bituminous surface treatments (chip seals) shall be applied to the road surface only when required or approved by the City Engineer. The

bituminous surface treatment shall consist of an application of bitumen covered with mineral aggregate and rolled to a smooth surface presenting an even texture, then coated with asphalt emulsion. The materials used in the application of the bituminous surface treatment shall be bituminous mineral, mineral aggregate, and asphalt emulsion specified as follows:

A. BITUMINOUS MATERIAL: The bituminous material shall be cationic emulsified asphalt (type CRS-LM {Latex Modified}), with a Saybolt Furol viscosity (at 122 degrees Fahrenheit) of between 300 and 400 seconds, and shall conform to the requirements as outlined in AASHTO Designation M208. The bituminous material shall also conform to the following requirements:

1. Sieve limit of 0.10 percent.
2. The particle charge shall be positive.
3. The Residue by evaporation shall be 65 percent by weight, minimum.
4. The results of the test on residue from distillation (tested in accordance with ASTM D-244) shall be as follows:

TESTS	MINIMUM	MAXIMUM
Penetration	100 mm.	250 mm.
Ductility	40 cm.	100 cm.
Solubility in Trichloroethylene	97.5%	100%

B. AGGREGATE (CHIPS): Mineral aggregate shall consist of crushed stone or crushed gravel, free from adherent films of clay or dust, and shall be of such nature that a thorough coating of the bituminous material used in the work will not strip off upon contact with water.

The gravel or rock shall have a percent of wear not greater than 30 when tested by the Los Angeles Abrasion Test (AASHTO T-9 ASTM C 131). Aggregate shall be cubical or pyramidal in shape with at least 85% fractured faces.

Stripping tests of the mineral aggregate, which the Contractor proposes to use, shall be furnished to the City Engineer before crushing operations begin. During the crushing of the aggregate, additional stripping tests shall be furnished to the City Engineer upon request. No stripping test shall show

a percent stripping greater than 10 for CRS-2 asphalt. The chip shall be electrically compatible to the asphalt emulsion used.

The crushed aggregate shall conform to the gradation requirements shown in table 4.8.

**TABLE 4.8
GRADATION OF AGGREGATE FOR CHIP SEAL COATS**

SIEVE SIZE	PERCENT BY WEIGHT PASSING (Ideal)	
	TYPE I	TYPE II
1/2 Inch	100	
3/8 Inch	70-100	
No. 4	0-20	100
No. 8	0-5	0-15
No. 200	0-2	0-1

The initial mineral aggregate used for the production of chips shall be retained on a 5/8 inch sieve prior to being crushed to the gradation specified.

C. ASPHALT EMULSION: See Section 4.3.1 IV

VI. STREET SIGN MATERIALS: Street sign materials shall conform to the following standards with the dimensions as indicated in the standard drawings:

A. ALUMINUM SIGN BLANKS: The aluminum sign blanks shall be extrusion aluminum, 0.080 inch thick for 6-inch blanks, ASTM B209 Alloy 6061-T6 or 6063-T5 and 6063-T6.

B. SIGN POSTS: Sign post shall be galvanized, 3/32 inch structural steel, ASTM A36, 2 inch square, perforated with 3/8 inch diameter holes, 1 inch on center on all four sides or pressure treated wood 4"x4".

C. MOUNTING SLEEVES: Mounting sleeves shall be the same as the sign post except 2 inch square.

D. REFLECTIVE SHEETING: Sign reflective sheeting shall be Class 4 for all background, letters, numerals, symbols, borders and accessories.

E. SIGN HARDWARE: All sign hardware shall be galvanized, ASTM A307 steel dimensioned according to the standard drawings.

F. SIGN COLORS AND FORMAT: Sign colors and format shall conform

to ANSI D6.1 and The Manual on Uniform Traffic Control Devices.

4.3.2 CONSTRUCTION METHODS AND EQUIPMENT: The methods employed in performing the work and all equipment, tools and machinery and other appliances used in handling the materials and executing the work shall be the responsibility of the Contractor. The Contractor shall make such changes in the methods employed and in the equipment used as are necessary whenever the road construction materials that are being installed do not meet the specifications herein established.

I. PIT RUN CONSTRUCTION METHODS AND EQUIPMENT: The methods employed in installing Pit Run shall include but not be limited to the following:

- A. When mixing and placing, the moisture content of the pit run shall be maintained at optimum, when tested, plus or minus 2%.
- B. When placing, the layers shall be of equal thickness not to exceed 6" in thickness.
- C. Do not place Pit Run on frozen subgrade or native material.
- D. Do not place additional material on any unacceptable layer.
- E. Material shall be deposited and spread in uniform lifts not to exceed six-inch compacted thickness, without segregation of size. When compacted, the Pit Run shall meet the required thickness.
- F. Each layer shall be compacted for the full width and depth by rolling with a pneumatic roller weighing at least 10 tons. Alternate blading and rolling will be required to provide a smooth, even and uniformly compacted course true to cross-section and grade. Places inaccessible to rolling shall be compacted with mechanically operated hand tampers. The Pit Run shall be compacted to not less than 95% maximum dry density as determined by ASTM D-1557.
- G. Surfaces shall be true to the established grade with thickness varying not more than 1 inch from the required layer thickness. Finish grade shall be established with hubs placed at 50-foot maximum spacing on centerline and shoulders.

II. ROAD BASE CONSTRUCTION METHODS AND EQUIPMENT: The methods employed installing road base shall include but are not limited to the following:

- A. When mixing and placing, the moisture content of the untreated base course shall be maintained at optimum, when tested, plus or minus 2%.

B. When placing, the layers shall be of equal thickness not to exceed 6" in thickness.

C. Do not place road base on frozen subgrade, sub-base or on a frozen layer of road base. No road base shall be installed from November 1st to April 1st unless approved by the City Engineer.

D. Do not place additional material on any unaccepted layer.

E. Material shall be deposited and spread in uniform lifts not to exceed six-inch compacted thickness, without segregation of size. When compacted, the Road Base shall meet the required thickness.

F. Each layer shall be compacted for the full width and depth by rolling with a pneumatic roller weighing at least 10 tons. Alternate blading and rolling will be required to provide a smooth, even and uniformly compacted course true to cross-section and grade. Places inaccessible to rolling shall be compacted with mechanically operated hand tampers. The Road Base shall be compacted to not less than 95% maximum dry density as determined by ASTM D-1557.

G. Surfaces shall be true to the established grade with thickness varying not more than 1/4 inch from the required layer thickness. Finish grade shall be established with hubs placed at 50-foot maximum spacing on centerline and shoulders.

III. BITUMINOUS PRIME COAT CONSTRUCTION METHODS: The methods employed in installing Bituminous Prime Coat shall include but are not limited to the following:

A. PREPARATION: Immediately prior to the application of the prime coat, all loose material, dirt, clay, or other objectionable material, shall be removed from the surface to be primed. After the cleaning operation, and prior to the application of the prime coat, the surface shall be steel rolled and lightly sprinkled with water immediately in advance of the application as directed by the Engineer, to assure a uniform spread of the bituminous material.

B. APPLICATION: Immediately following the preparation of the base course, the bituminous prime material shall be applied at the rate of .25 gallon per square yard of surface course by means of a bituminous distributor at the temperature specified. The asphalt distributor shall be equipped with a calibrated dipstick marked in gallons per inch of length, and an accurate thermometer and speedometer. The distributor shall also be able to maintain the correct pump speed of pressure without either atomizing the asphalt or distorting the spray fan. However, the pump shall

be able to maintain a pressure that shall be sufficient to prevent streaking from a non-uniform discharge of material from the individual nozzles.

The asphalt distributor shall be equipped with a rear mounted spray bar capable of covering widths of 6 to 15 feet in a single pass. The distributor tank shall be well insulated and be equipped with one or more heaters capable to bringing the asphalt material to spray application temperature. The tank shall have a full circulating system with an engine-driven pump. The circulating system shall include the spray bar unit. The truck shall also be equipped with a hand-spray for applying the asphalt material to areas that cannot be reached with the spray bar.

The distributor shall be equipped with charts for determining the discharge for each nozzle's size, the proper truck speeds for various application rates, and the correcting of temperature-viscosity variations. The operator of the asphalt distributor shall be capable of applying the material as specified. If the operator is incapable of performing the work, at the request of the City, he/she shall be removed.

C. CURING: Following the application of prime material, the surface shall be allowed to dry for a period of not less than 48 hours without being disturbed, or of such additional period of time as may be necessary to attain penetration into the foundation course and drying out or evaporation of the volatiles from the prime material, which period shall be determined by the City Engineer. The Contractor shall furnish and spread sufficient approved sand on all areas that show an excess of bituminous material to effectively blot up and cure the excess, as directed by the City Engineer. The primed surface shall be maintained by the Contractor, and he/she shall repair all broken spots.

D. WEATHER LIMITATIONS: Bituminous material for the prime coat shall only be applied when the minimum temperature of the air or road bed is 50 degrees and rising. Application conditions shall be subject to the discretion of the City Engineer.

IV. BITUMINOUS SURFACE COURSE CONSTRUCTION METHODS AND EQUIPMENT: The methods employed in installing Bituminous Surface Course shall include but are not limited to the following:

A. MIXING: The bituminous surface course shall be mixed at a mixing plant and spread and compacted on the prepared base in conformance with the lines and dimensions shown on the plans and in accordance with these Standards.

The combined mineral aggregate plus any specified additives when

mixed with the specified bituminous binder in accordance with ASTM Designations D-6926 and D-6927 shall conform to the requirements shown in Table 4.9.

**TABLE 4.9
BITUMINOUS SURFACE COURSE SPECIFICATION**

Marshall stability	1200 pounds minimum
Flow (0.01 inch)	10-18
Voids Content	2% to 4%
Los Angeles Abrasion Test	30% Max. loss in 500 revolutions
Fractured face	75% min.
Asphalt Content	According to approved design mix ∇ 0.3%.
RAP Content	15% maximum of total mix weight

B. SPREADING: The bituminous mixtures shall be spread with self-propelled mechanical spreading and conditioning equipment capable of distributing at least a 12-foot width. The spreader shall be equipped with an automatic leveling screed. The mixture shall be spread and struck off in such a manner that the finished surface will result in a uniform smooth surface. The longitudinal joints in succeeding courses shall be off-set at least 12 inches vertically to avoid a vertical joint through more than one course. All transverse joints shall be offset from one another at least four feet longitudinally, except as required by the City Engineer. The temperature of the bituminous mix shall be between 250 degrees and 325 degrees F. when placing. When the thickness of the bituminous surface course is four or more inches, it shall be installed in two or more lifts or courses. The top lift of that bituminous surface course shall be at least 2 inches thick. The ½ inch material for aggregate shall be used in the bituminous surface course for the top lift of a multi-lift installation and the one lift for a single lift installation.

C. COMPACTION: After the mixture has been spread, the surface shall be rolled in longitudinal direction commencing at the outside edge or lower side and proceeding to the higher side. Each pass of the roller shall overlap the preceding pass at least one-half the width of the roller. Rolling shall continue until 96% of the laboratory bulk density has been obtained. Rolling operations shall be conducted in such a manner that shoving or distortion will not develop beneath the roller. The surface of the pavement, after compaction, shall be uniform and true to the established crown and grade. All traffic shall be kept off the surface until rolling is completed.

D. TEMPERATURE LIMITATIONS: No bituminous surface course shall be placed when the temperature of the air or road bed is 50 degrees F. or below; during rainy weather; when the base is wet; during the period from November 1st through April 1st or during other unfavorable conditions as determined by the City Engineer. However, minor repairs will be allowed during winter months. The air temperature shall be measured in the shade. The temperature of the bituminous mix shall be between 250 degrees and 325 degrees F. when placing.

V. BITUMINOUS FLUSH COAT CONSTRUCTION METHODS: The methods employed in installing Bituminous Flush Coat shall include but are not limited to the following:

A. SURFACE PREPARATION: The Contractor shall thoroughly remove all dust, dirt, tracked on clay and foreign material from the surfaces to be sealed by sweeping the surface with power brooms, hand brooms, power blowers, or by flushing it with water or a combination of the above. All patching, crack filling and drainage improvements shall be completed prior to the commencement of the surface treatment project.

After the cleaning operation has been completed, and prior to the application of the surface treatment, the area to be treated will be inspected by the City Engineer to determine its fitness for receiving the surface treatment.

B. EMULSION APPLICATION: Anionic emulsion shall be used and shall be applied at the rate of 0.08 to 0.20 gallons per square yard as determined by the City Engineer. The asphalt emulsion shall be diluted at the rate of 1:1 with potable water. An asphalt distributor conforming to Section 4.3.2.III.B shall be used to apply the emulsion at the specified temperature. The emulsion shall not be placed within 3 days after new bituminous surface course has been laid. The emulsion shall all be placed 7 days prior to any striping of the bituminous surface course.

C. BLOTTING: Any excess emulsion that does not cure after 2 hours shall receive a covering of blotter sand.

D. WEATHER LIMITATION: The flush coat shall be placed only when the air temperature in the shade and the road bed temperature are above 50 degrees F. The flush coat shall not be placed when the temperature of the road surface is above 130 degrees F., during rainy weather, when the road is wet or during other unfavorable weather conditions as determined by the City Engineer.

VI. BITUMINOUS CHIP SEAL CONSTRUCTION METHODS: The methods

employed in installing Bituminous Chip Seal shall include but are not limited to the following:

A. SURFACE PREPARATION: The Contractor shall thoroughly remove all dust, dirt, tracked on clay and foreign material from the surfaces to be sealed by sweeping the surface with power brooms, hand brooms, power blowers, or by flushing it with water or a combination of the above. All patching, crack filling and drainage improvements shall be completed prior to the commencement of the surface treatment project. After the cleaning operation has been completed, and prior to the application of the surface treatment, the area to be treated will be inspected by the City Engineer to determine its fitness for receiving the surface treatment.

B ASPHALT APPLICATION: The asphalt material shall be applied at 0.40 to 0.60 gallon per square yard as determined by the City Engineer and at a temperature between 125 degrees to 185 degrees Fahrenheit. The exact temperature used to apply the bituminous material shall be determined by the City Engineer. Application of the asphalt shall not be permitted to begin until the loaded aggregate trucks are in place and ready to apply the cover aggregate. The bituminous material shall be applied by an asphalt distributor as described in Section 4.3.2.III.B so that uniform distribution in the quantities specified is obtained over all points of the surface to be treated.

All lightly-coated areas and spots missed by the distributor shall be properly treated with bituminous material applied by hand. No more asphalt shall be applied than can be covered with aggregate in 30 seconds or less. Distances between the distributor and chip-spreader shall be as close as possible, but in no case shall the chip-spreader be greater than 50 feet behind the distributor during the chipping operations.

C. AGGREGATE SPREADING: Immediately following the application of the bituminous material, the aggregate shall be evenly spread at a uniform quantity of 15 to 20 pounds per square yard of surface area. Upon commencement of the work, and during its progress, the individual quantities of bitumen and aggregate may be varied to meet specific field conditions, as directed by the City Engineer. An adequate supply of aggregate shall be available on the job site to permit continual spreading operations. The aggregate shall be spread by using a self-propelled spreader (Fairly or equal). The aggregate shall be spread evenly by hand on all areas missed by the aggregate spreader. Back-spotting or sprinkling of additional aggregate over the areas having insufficient cover shall be done by hand and shall be continued during the operations whenever necessary.

As the distributor moves forward to spray the asphalt, the aggregate

spreader shall start right behind it, spreading the chips uniformly and at the specified rate. The asphalt distributor shall travel at the same rate of speed as the chip spreader and in no case shall the two machines be separated by more than 50 feet during the sealing process. Operating the chip spreader at speeds that cause the chips to roll over after striking the bituminous-covered surface will not be permitted.

D. AGGREGATE COMPACTION: Excess aggregate deposited in localized areas shall be immediately removed with square-end shovels, and in areas where application is insufficient, additional aggregate shall be added by hand. The treated surface shall be rolled with rubber-tired rollers immediately after the distribution of the cover aggregate, and shall continue until the aggregate is properly seated in the binder. Rollers shall proceed in the longitudinal direction, working across the treated surface until the entire width and length of the treated surface has been rolled at least four times. Rollers and gravel trucks shall not be operated at speeds great enough to kick up chips, and in no case shall rollers be operated above 10 miles per hour. In all places not accessible to the rollers, the aggregate shall be adequately compacted with hand tampers. Any aggregate that becomes coated or mixed with dirt or any other foreign material shall be removed, replaced with clean aggregate over a newly-sprayed surface, and then re-rolled as directed by the City Engineer.

Bituminous material and chips shall not be spread more than 100 feet ahead of completion of initial rolling operations. To eliminate excessive ridging, all joint edges shall be swept prior to the application of the second course of aggregate on double chip seal treatments.

E. LOOSE AGGREGATE REMOVAL: Upon completion of rolling, traffic will be allowed to use the streets at a speed not to exceed 15 miles per hour for a period of not less than 24 hours. After the chips are set in the bituminous binder, but not earlier than the following day, any loose chips forming corrugations shall be distributed over the surface. At the end of seven days, any excess chips shall be removed in such a manner that the aggregate set in the binder will not be displaced. Excessive rolling or brooming will not be permitted.

F. ASPHALT EMULSION APPLICATION: Asphalt emulsion "Flush Coat" shall then be applied to the finished, chipped surface according to Section 4.3.2.V.

G. MISCELLANEOUS CLEAN UP: After the surface has been opened to traffic, any excess bituminous binder that comes to the surface shall be immediately covered with additional chips or clean sand. The completed surface shall present a uniform appearance and shall be thoroughly compacted and free from ruts, humps, depressions or irregularities due to an uneven distribution of bituminous binder or chips.

H. WEATHER LIMITATIONS: The chip seal shall be placed only when the air temperature in the shade and the road bed temperature are above 75 degrees F. The chip seal shall not be placed when the temperature of the road surface is above 130 degrees F., during rainy weather, when the road is wet or during other unfavorable weather conditions as determined by the City Engineer.

VII. STREET SIGN INSTALLATION METHODS: Street signs shall be installed as follows and placed according to the standard drawings:

- A. Posts shall be installed in the post sleeve that is driven plumb into compacted earth.
- B. All joints shall be cut flat and true.
- C. Connections shall be tight.
- D. Sign faces shall be cleaned and in the proper orientation.

4.3.3 QUALITY CONTROL: Roadway Construction in City improvements shall have the minimal testing and acceptance standards as follows and conform to the requirements outlined in Section 1.4 of these standards.

I. BASE COURSE QUALITY CONTROL: All base course (both pit run and road base materials) shall be placed in accordance with these standards, and tested and accepted as follows:

A. TESTING: Minimum testing of the base course shall be as follows:

Gradation Tests: One test per 15,000 sq. feet of roadway surface area or fraction thereof. The sieve analysis shall be according to ASTM C136, C117. Care shall be exercised in sampling where both 1-inch and 3/4-inch base course has been used so blending does not occur.

Soil Proctor: One determination for each source of base course as necessary to provide required compaction testing. Tests shall be according to ASTM D1557, Method A or D (modified proctor).

Moisture/
Density Tests:

One test per 7,000 sq. feet of roadway surface area or fraction thereof. Moisture content shall be at optimum plus or minus 2 percent for test to pass and shall be maintained until prime coat or asphalt is applied. Tests shall be according to ASTM D1556 or D2922 and D3017.

Thickness:

One random boring or test hole per 5,000 sq. feet of surface area or fraction thereof to verify required thickness. If sufficient inspection has been made by a City Engineer to verify required thickness, the City Engineer may waive thickness testing.

No single measured thickness shall be less than the required design thickness.

Testing documentation shall be according to Section 2.4 of these standards.

B. ACCEPTANCE: Any base course determined not to be in compliance with these standards shall either be removed and replaced or re-worked until compliance is obtained. Any costs for testing re-work shall be paid for by the developer.

II. BITUMINOUS SURFACE COURSE QUALITY CONTROL: All bituminous surface course shall be placed in accordance with these standards and tested as follows:

A. TESTING. Minimum testing of the bituminous surface course is as follows:

Material

Certification:

Each project shall submit independent written certification through the material supplier that surface course materials comply with these City standards.

All material certification tests shall be according to ASTM D1559 (modified).

Certification for a material source previously approved for the current construction season will be acceptable provided sources of the individual components of the combined surface course mix have not changed.

Extraction-
Gradation Test: One test per 500 tons of material placed or one per day whichever is more. Tests shall be according to UDOT test procedures 8-946 and 8-947.

Field Density Tests: One test per 7,000 sq. ft. of surface area or fraction thereof. Tests shall be according to ASTM D2950.

Thickness Tests: One core sample from each section of 10,000 sq. ft. or fraction thereof. At the discretion of the City Engineer, thickness testing may be waived for material placed in public roadway construction if sufficient inspection has been made by the City Engineer to verify required thickness.

Testing documentation shall be according to Section 2.4 of these standards.

B. ACCEPTANCE: Any bituminous surface course determined not to be in compliance with these standards shall either be removed and replaced or re-worked until compliance is obtained. Any costs for testing re-work shall be paid for by the developer.

III. BITUMINOUS FLUSH COAT QUALITY CONTROL: All bituminous flush coat material shall be placed in accordance with these Standards and certified as follows:

Material Certification: For each job, the supplier shall submit a report from a certified testing laboratory that the Asphalt Emulsion conforms to these City Standards.

IV. BITUMINOUS CHIP SEAL QUALITY CONTROL: All bituminous chip seal materials (CRS-2 and chips) shall be placed in accordance with these Standards and certified as follows:

Material Certification: Each job shall submit independent written certification through the material supplier that both the bituminous material and aggregate comply with these City Standards.

4.4 CONCRETE WORK: This section of the Standards defines the materials to be used and the requirements for mixing, placing, finishing and curing all Portland cement concrete work on public improvements within Enoch City. The concrete supplier shall submit a mix design for both classes of concrete and flowable fill to the City Engineer for approval prior to the commencement of each construction season or upon a change in the aggregate source or other materials in the mix. The mix design shall include all additives proposed to be used. Material information sheets shall be provided for all additives.

4.4.1. MATERIALS. Concrete construction materials in City improvements shall conform to the following requirements:

I. PORTLAND CEMENT CONCRETE MATERIAL: The concrete shall be composed of coarse aggregate, fine aggregate, Portland Cement and water, and shall conform to the following requirements:

A. PORTLAND CEMENT: ANSI/ASTM C 150, Type I, low alkali, unless otherwise indicated, or acceptable to the City Engineer.

Use Type II or Type V cement for concrete that will be in contact with soil, excluding floor slabs.

Use one brand of cement throughout project, unless otherwise acceptable to City Engineer.

B. AGGREGATES. Except as otherwise specified herein, concrete aggregates shall conform to all applicable provisions of the latest revision of ASTM Standard Specification C 33.

1. Fine Aggregate: Fine aggregate shall consist of natural sand or, subject to approval, other inert materials with similar characteristics, having clean, hard, durable, uncoated grains and shall conform to the requirements of these standards. The amount of deleterious substances shall not exceed the following limits:

MATERIAL	PERCENT (by weight)
Clay Lumps	1.00
Coal and lignite	0.50
Material passing No. 200 sieve	3.00
Other deleterious substances such as shale, alkali, mica, coated grains, soft and flaky particles, etc.	3.00

The sum of the percentage of all deleterious substances shall not exceed five percent by weight.

Fine aggregate shall be well graded and shall range in size from fine to coarse within the following percentages by weight:

SIEVE SIZE	PERCENT PASSING (by weight)
3/8 inch	100
No. 4	95-100
No. 8	80-90
No. 16	50-75
No. 30	30-50
No. 50	10-20
No. 100	2-5

3. Coarse Aggregate: Coarse aggregate shall consist of crushed stone, gravel, slag or other approved inert material with similar characteristics or combination thereof, having clean, hard, durable, uncoated particles free from deleterious matter. Deleterious substances shall not be present in the aggregate in excess of the following limits:

MATERIAL	PERCENT (by weight)
Soft fragments	2.00
Coal and lignite	0.30
Clay Lumps	0.25
Material passing No. 200 sieve	1.00
Other deleterious substances such as shale, alkali, mica, coated grains, soft and flaky particles, etc.	3.00

The sum of the percentages of all deleterious substances in any size or delivered to the mixer, shall not exceed five percent (5%), by weight.

Coarse aggregate may be rejected if it fails to meet the following test requirements:

a. Los Angles Abrasion Test: If the percent of loss by weight exceeds ten percent at 100 revolutions, or forty percent at 500 revolutions.

b. Sodium Sulfate Test for Soundness: If the weighted average loss after five cycles is more than twelve percent by weight.

c. Gradation: Coarse aggregate shall be graded by weight as follows:

SIEVE SIZE	PERCENT PASSING (by weight)
1 inch	100
3/4 inch	90-100
3/8 inch	20-55
No. 4	0-10
No. 8	0-5

The maximum size of the aggregate shall be not larger than one-fifth of the narrowest dimension between forms within which the concrete is to be incased, and in no case larger than three-fourths of the minimum clear spacing between reinforcing bars or between reinforcing bars and forms. For un-reinforced concrete slabs, the maximum size of aggregates shall not be larger than one-fourth the slab thickness.

C. WATER. Sufficient potable water shall be added to the mix to produce concrete with the minimum practical slump, and in no case shall the slump be greater than 4 inches.

The maximum permissible water-cement ratio (including free moisture in the aggregate) shall be 5 gallons per bag of cement (0.44) for Class A and 5 3/4 gallons per bag of cement (0.51) for Class C concrete. If Pozzolan is added to the concrete mix the weight of the pozzolan shall be added to the cement weight to determine the water-cement ratio.

D. ENTRAINING AGENT. An air-entraining agent shall be used in all concrete exposed to the weather. The agent shall conform to ASTM designation C 260. Air content for air-entrained concrete shall be 5% by volume (plus or minus 1%). The air-entraining agent shall be added as a liquid to the mixing water by means of mechanical equipment capable of accurate measurement and control.

E. ADMIXTURES.

1. Pozzolan. 20% maximum of the concrete mix cement weight may be replaced with pozzolan conforming to the requirements of ASTM C 618 Class N and AASHTO M295.

Pozzolans shall be sampled and tested as prescribed in ASTM C 618 and ASTM C 311. The contractor shall obtain and deliver to the City Engineer a certification of compliance signed by the Pozzolan supplier identifying the Pozzolan and stating that the Pozzolan delivered to the batching site complies with applicable specifications.

Pozzolan material shall be handled and stored in the same manner as Portland cement. When facilities for handling bulk Pozzolan are not available, the Pozzolan shall be delivered in original unopened sacks bearing the name and brand of supplier, the type and source of the Pozzolan, and the weight contained in each sack plainly marked thereon.

Different brands or types of pozzolan shall not be mixed together unless written permission has first been obtained from the City Engineer. All Pozzolan used in the manufacture of concrete for any individual structure shall be of the same type, and from the same source unless otherwise approved by the City Engineer.

2. Calcium Chloride. No calcium chloride shall be added to any concrete mix. Non-chloride accelerators may be used with permission of the City Engineer.

F. CONCRETE MIX. For the purpose of practical identification, concrete has been divided into classes. The basic requirements of class A, B and class C and the use for each is defined in Table 4.10.

**TABLE 4.10
CONCRETE MIX SPECIFICATIONS**

CLASS	MINIMUM CEMENT CONTENT		MAXIMUM WATER CONTENT (gal./bag of cement)	MAXIMUM SLUMPS	MINIMUM 28-DAY COMP. STRENGTH (psi)	PRIMARY USE
	(Bags/ C.Y.)	(pounds/ C.Y.)				
A	7	658	4.43	4"	5000	Cross Gutters
B	6	564	5	4" 2"*	4000	Reinforced structural concrete; side-walks; curbs & gutters; cross gutters; pavements; unreinforced footings
C	5	470	5.75	4"	3000	Minor non-structural items such as thrust blocks; anchors, mass concrete, etc.

Unless specifically waived by the City Engineer all concrete placed shall be Class "A", six-bag mix, and the minimum allowable compressive strength of concrete at the age of 28 days shall be 4000 p.s.i.

* For machine placement, sections should not deform.

II. CONCRETE REINFORCING MATERIALS. Concrete reinforcing materials shall conform to the following:

A. STEEL BARS. All bar material used for reinforcement of concrete shall be intermediate or hard grade steel conforming to the requirements of ASTM Designation A 615 and shall be deformed in accordance with ASTM Designation A 615. All reinforcing steel shall be minimum grade 60 unless approved otherwise by the City Engineer.

All bars shall be deformed-round and have a net section equivalent to that of plain bar of equal nominal size. Only intermediate and/or hard grades

will be used and no twisted bars will be accepted.

All reinforcing steel, at the time concrete is placed, shall be free from flaws, cracks, mill scale, rust, oil, dirt, paint, (unless epoxy coated) or other coatings that will destroy or reduce the bond.

B. WIRE OR WIRE MESH REINFORCEMENT. Welded wire fabric for concrete reinforcement shall conform to the requirements of ASTM A 185. Wire for concrete reinforcement shall conform to the requirements of the "Standard Specification for Cold Drawn Steel Wire for Concrete Reinforcement" ASTM A 82. All wire reinforcement, wire mesh, or expanded metal shall be of the type designated unless an alternate type is approved by the City Engineer.

C. STEEL FIBER REINFORCEMENT. Deformed steel fiber for concrete reinforcement shall conform to the requirements of ASTM A 820, type I, deformed fiber, except that the average tensile strength shall be not less than 150,000 psi.

D. ENGINEERED SYNTHETIC REINFORCING FIBERS. Engineered synthetic reinforcing fibers shall be 100% polypropylene collated, fibrillated fibers. Fiber length and amount per manufacturer's recommendations shall correspond with the concrete mixture.

Physical properties of the fibers shall be as follows:

Specific gravity	0.91
Modulus of elasticity	500,000 to 700,000 psi
Tensile strength	70,000 to 110,000 psi
Length	0.25 to 2.50 inches

The fiber manufacturer shall certify that all polypropylene fibers meet the physical properties, and are specifically manufactured for use in concrete from virgin polypropylene, containing no reprocessed olefin materials. If the fiber manufacturer is other than the brand name listed on the literature and packaging, the certification must be from the original manufacturer of the fibers.

III. CONCRETE BASE MATERIALS: Concrete base materials shall conform to the following:

A. SUBGRADE: The subgrade shall be excavated and filled with suitable material as specified in Section 4.1.2 of these standards to within six inches

of the required grades for curbs and gutters, waterways, driveways, and sidewalks. All soft, yielding and otherwise unsuitable material shall be removed and replaced with suitable materials as outlined above. Filled sections shall be compacted and extend to a minimum of one foot outside the form lines according to Section 4.1.3. III of these standards.

B. GRAVEL BASE COURSE. A gravel base course consisting of 3/4" maximum crushed road base gravel six-inches thick shall be placed under all curbs, gutters, driveways, waterways and sidewalks. Where the foundation material is found to be unstable, the Contractor shall furnish and place sufficient extra gravel fill as directed by the City Engineer to firm up the soil upon which the curb, gutter and sidewalk is to be placed.

4.4.2. CONSTRUCTION METHODS & EQUIPMENT: The methods employed in performing the work, all equipment, tools and machinery, and other appliances used in handling the materials and executing the work shall be the responsibility of the Contractor. The Contractor shall make such changes in the methods employed and in the equipment used as are necessary whenever the concrete being installed does not meet the specifications herein established. These methods shall include but not be limited to:

I. GENERAL CONCRETE PLACEMENT: Generally concrete shall be installed as follows:

A. FORMS. Forms shall be substantially built and adequately braced so as to withstand the liquid weight of concrete. All linings, studding, walling and bracing shall be such as to prevent bulging, spreading, or loss of true alignment while pouring and displacement of concrete while setting.

B. PREPARATIONS. Before batching and placing concrete, all equipment for mixing and transporting the concrete shall be cleaned, all debris and ice shall be removed from the places to be occupied by the concrete, forms shall be oiled with a form-release agent, and masonry filler units that will be in contact with concrete shall be well drenched with water (except in freezing weather), and the reinforcement shall be thoroughly cleaned of ice or other coatings. Water shall be removed from spaces to receive concrete.

When placing concrete on earth surfaces, the surfaces shall be free from frost, ice, mud and water. When the subgrade is dry soil or pervious material, it shall be sprayed with water prior to the placing of concrete or shall be covered with water-proof sheathing paper or a plastic membrane. No concrete shall be placed until the surfaces have been inspected and approved by the City Engineer.

C. CONCRETE MIXING. The concrete shall be mixed until there is a uniform distribution of the materials. Sufficient water shall be used in concrete in which reinforcement is to be imbedded, to produce a mixture

which will flow sluggishly when worked and which, at the same time, can be conveyed from the mixer to the forms without separation of the coarse aggregate from the mortar. In no case shall the quantity of water used be sufficient to cause the collection of a surplus in the forms.

Ready-mixed concrete shall be mixed and delivered in accordance with the requirements set forth in Specifications for Ready-Mixed Concrete (ASTM C 94). Concrete shall be delivered and deposited in its final position within 60 minutes after adding the cement and water to the mixture.

D. DEPOSITING. Concrete shall be deposited as nearly as practical in its final position to avoid segregation due to rehandling or flowing. The concrete placing shall be carried on at such a rate that the concrete is at all times plastic and flows readily into the corners of forms and reinforcing bars. No concrete that has partially hardened or been contaminated by foreign material shall be deposited in the work, nor shall re-tempered concrete be used.

All concrete in structures shall be compacted by means of high-frequency internal vibrators of approved type and design during the operation of placing, and shall be thoroughly worked around reinforcement and embedded fixtures and into the corners of the forms. Care must be taken not to over use vibrators causing separation of cement and aggregates.

E. FINISHING. After the concrete for slabs has been brought to the established grade and screeded, it shall be worked with a magnesium float and then given a light "broom" finish. In no case shall dry cement or a mixture of dry cement and sand be sprinkled on the surface to absorb moisture or hasten hardening. Surface edges of all slabs shall be rounded to a radius of 1/4 to 1/2 inch with standard concrete finishing tools.

F. CURING AND PROTECTION. As soon as the concrete has hardened sufficiently to prevent damage, the finished surface shall be kept moist for seven days, or a chemical curing agent may be used to prevent the concrete from premature drying.

The freshly finished surface shall be protected from hot sun and drying winds until it can be sprinkled or covered as above specified. The concrete surface must not be damaged or pitted by rain. The Contractor shall provide and use, when necessary, sufficient tarpaulins to completely cover all sections that have been placed within the preceding 12 hours. The Contractor shall erect and maintain suitable barriers to protect the finished surface. Any section damaged from traffic, weather or other causes occurring prior to its official acceptance, shall be repaired or replaced by the Contractor in a manner satisfactory to the City Engineer.

G. WEATHER LIMITATIONS: No concrete shall be poured where the air temperature is lower than 35 degrees F. or from the period of November 1 to April 1 of each year unless approved by the City Engineer. When there is likelihood of freezing during the curing period, the concrete shall be protected by means of an insulating covering to prevent freezing of the concrete for a period of not less than seven days after placing or optionally to maintain the concrete temperature above 50° F for at least 3 days, with no intermittent days below 32° F. Equipment for protecting the concrete from freezing shall be available at the job site prior to placing concrete. Particular care shall be exercised to protect edges and exposed corners from freezing.

H. CONCRETE REPAIR:

- 1- Minor Cracking. In lieu of removing and replacing concrete with minor cracks, the City Engineer may direct the Contractor to repair the affected sections by sawing, cleaning and sealing the cracks. All cracks repaired shall be sealed with a polyurethane TTS-230 type II crack filler, or an approved silicone type crack filler Sika Flex Construction Sealant or equal approved by the City Engineer. Where modifications are to be made to existing concrete, the edges to be poured against shall be sawed and the new concrete shall be edged with a standard edging tool. Sections of curb and gutter or sidewalk shall be removed and replaced if there are more than one crack per section that is not in a joint or three or more consecutive sections with a crack that is not in a joint. A section is the area between contraction joints and/or expansion joints.
- 2- Minor Spalling. In lieu of removing and replacing concrete with surfaces that have minor spalling on the concrete surface , the City Engineer may direct the Contractor to repair the affected sections by use a two-component, polymer-modified, Portland cement, fast setting, non-sag mortar Sikatop 123 PLUS or equal approved by the City Engineer. The preparation of the concrete surface and the installation of the mortar material shall the done as directed by the mortar manufacturer.

II. CONCRETE REINFORCEMENT INSTALLATION: Concrete reinforcement shall be installed as follows:

A. BENDING. Reinforcing bars shall be accurately formed to the dimensions indicated on the Plans. Bends for stirrups and ties shall be made around a pin having a diameter not less than two times the minimum thickness of the bar. Bends for other bars shall be made around a pin having a diameter not less than six times the minimum thickness of the bar,

except that for bars larger than one inch, the pin shall be not less than eight times the minimum thickness of the bar.

B. SPLICING. Splicing of bars at points other than as shown on the Plans will be permitted only by permission of the City Engineer. Splices of reinforcement at points of maximum stress shall be avoided wherever possible, and shall be staggered when used. The minimum overlap for a lapped splice shall be 24 bar diameters, but not less than 12 inches.

C. PLACING. All reinforcing bars shall be placed accurately in the position shown on the Plans, and shall be securely held in position by annealed iron wire ties of not less than 16 gauge or suitable clips at intersection and supported by metal supports, spacers or hangers, in such a manner that there will not be any displacement while placing concrete. Reinforcing bar dowels shall either be poured or epoxied into concrete.

D. EMBEDMENT AND PROTECTION. All reinforcing steel shall be protected by concrete embedment and protective cover as shown in table 4.11, such cover in each case being the shortest distance between the face of the form or concrete surface, and the nearest edge or face of the reinforcement.

**TABLE 4.11
REINFORCING BAR CLEARANCE**

LOCATION OF REINFORCEMENT	COVER
Bottom bars - where concrete is deposited against ground without use of forms.	Not less than 3"
Main bars - where concrete is exposed to the weather, or exposed to the ground but placed in forms.	Not less than 2"
Bars in slabs and walls not exposed to the ground or weather.	Not less than 1"

E. FIBERMESH INSTALLATION. Fiber-mesh shall be added, according to the manufacturer's recommendations, only at the concrete batch plant to assure uniform and complete dispersion of the collated-fibrillated fiber bundles into single mono-filaments within the concrete.

III. CURB & GUTTER CONCRETE PLACEMENT. The concrete shall be placed either by an approved slip form/extrusion machine, by the formed method, or by a combination of those methods. Curb and gutter shall be placed as follows:

A. MACHINE PLACEMENT. The slip form/extrusion machine approved

shall be so designed as to place, spread, consolidate, screed, and finish the concrete in one complete pass in such a manner that a minimum of hand finishing will be necessary to provide a dense and homogeneous concrete section. The machine shall shape, vibrate, and/or extrude the concrete for the full width and depth of the concrete section being placed. It shall be operated with as nearly a continuous forward movement as possible. All operations of mixing, delivery, and spreading concrete shall be so coordinated as to provide uniform progress, with stopping and starting of the machine held to a minimum.

B. FORMED METHOD. The forms shall be of wood, metal, or other suitable material that is straight and free from warp, having sufficient strength to resist the pressure of the concrete without displacement and sufficient tightness to prevent the leakage of mortar. Flexible or rigid forms of proper curvature may be used for curves having a radius of 100 ft. or less. Division plates shall be metal.

The front and back forms shall extend for the full depth of the concrete. All forms shall be braced and staked so that they remain in both horizontal and vertical alignment until their removal. They shall be cleaned and coated with an approved form-release agent before concrete is placed against them. The concrete shall be deposited into the forms without segregation and then tamped and spaded or mechanically vibrated for thorough consolidation. Front and back forms shall be removed without damage to the concrete after it has set.

C. FINISHING. The plastic concrete shall be finished smooth, if necessary, by means of a wood or magnesium float and then given a final surface texture using a light broom or burlap drag. Concrete that is adjacent to forms and formed joints shall be edged with a standard jointer or edging tool to the dimensions shown on the plans. The top, face, and flow-line of the curb and also the top of the apron on driveway aprons shall be finished true to line and grade and without any irregularities of surface noticeable to the eye.

The gutter shall not pond water when tested by water flow and no portion of the surface of the curb and gutter shall depart more than one-fourth of an inch from a straight edge, ten feet in length, placed on the curb parallel to the center line of the street, nor shall any part of the exposed surface present a wavy appearance.

D. JOINTING.

1. Contraction Joints. Transverse weakened-plane contraction joints shall be constructed at right angles to the curb line at intervals not exceeding 10 ft. for curb and gutter, and not to exceed 5 ft. for

sidewalks. Joint depth shall at least be one-eighth of the cross section of the concrete. Generally, surface areas shall not exceed 100 square feet without contraction joints, AND SPACING BETWEEN CONTRACTION JOINTS SHALL NOT EXCEED TEN FEET. Contraction joints shall be hand formed using a narrow jointing tool or a thin metal blade to impress a plane of weakness into the plastic concrete of the required depth. Other methods of installing contraction joints such as saw cutting or metal strip insertion shall be approved by the City Engineer. Saw cutting shall be done within 24-hours after the concrete has set. Steel strips shall be one eighth-inch thick and inserted into the plastic concrete temporarily and withdrawn before final finishing.

2. Expansion Joints. Expansion joints for curb, gutter and sidewalk shall be constructed at right angles to the curb line, at locations shown in the standard drawings. Spacing for sidewalk expansion joints shall not exceed 40 feet. Filler material for expansion joints shall conform to requirements of ASTM D 994, D 1751, or D 1752 and shall be furnished in a single 1/2-inch thick piece for the full depth and width of the joint.

3. Other Jointing. Construction joints may be either butt or expansion-type joints. Curbs and gutters constructed adjacent to existing concrete shall have the same type of joints as in the existing concrete with similar spacing, however, contraction joint spacing shall not exceed 10 ft. A silicone joint sealer as defined in ASTM C 962 shall be applied to all form-plate expansion joints. The silicone joint sealer shall be applied under pressure to a depth of not less than two inches from the outside surface of the curb and gutter.

E. PROTECTION. At all times during the construction of the project, the Contractor shall have materials available at the site to protect the surface of the plastic concrete against rain. These materials shall consist of waterproof paper or plastic sheeting. For slip-form construction, materials such as wood planks or forms to protect the edges shall also be required.

F. CURING. Concrete shall be cured for at least three days after placement to protect it against loss of moisture, rapid temperature change, and mechanical injury. Moist burlap, waterproof paper, polyethylene sheeting, liquid membrane curing compound, or a combination thereof may be used as the curing material. Membrane curing shall not be permitted in frost-affected areas when the concrete will be exposed to deicing chemicals within 30 days after completion of the curing period.

G. BACKFILLING. After at least three days after placement and the forms have been removed from the concrete, the Contractor shall backfill to

the line and elevation as shown on the drawings or as required by the City Engineer.

H. WEATHER LIMITATIONS: See section 4.4.2.I.G.

I. CONCRETE REPAIR: See section 4.4.2.I.H.

IV. CONCRETE BASE MATERIALS PLACEMENT: The placement of concrete base materials (pit run and road base) under curb, gutter and sidewalk shall conform to Sections 4.3.2.I and 4.3.2.II of these standards.

4.4.3. QUALITY CONTROL. All concrete and base materials shall be placed in accordance with these standards and tested as follows:

I. CONCRETE TESTING. Minimum testing of the concrete shall be as follows:

- Mix Design
Certification: One per calendar year or anytime when mix design changes.
Testing shall be according to the latest ASTM standards.
- Compressive
Strength Tests: One set of (4) cylinders for each 50 cubic yards of concrete placed. Test 1 cylinder at 7 days, 2 cylinders at 28 days and 1 cylinder shall be held by the testing firm for a maximum of 90 days to be broke when directed by the City Engineer. Tests shall be according to ASTM C39.
- Air Entrainment: One test at beginning of load placement or two consecutive passing tests if initial test fails. Others shall be taken as required. Tests shall be according to ASTM C231.
- Slump Tests: One test at beginning of load placement or two consecutive passing tests if initial test fails. Others shall be taken as required. Tests shall be according to ASTM C143.

II. CONCRETE BASE MATERIAL TESTING. Minimum testing of the curb, gutter and sidewalk base materials (both pit run and road base materials) shall be tested as follows:

- Gradation Tests: One test per 2000 lineal feet of curb & gutter and one test per 2000 lineal feet of sidewalk or fraction thereof.
The sieve analysis shall be according to ASTM C136, C117.
- Soil Proctor: One determination of each source of base course as necessary to provide required compaction testing. Test shall be according to ASTM D1557, Method A or D (modified

proctor).

Moisture Density

Tests: One test per 300 lineal feet of curb & gutter and one test per 300 lineal feet of sidewalk or fraction thereof. Moisture content shall be at plus or minus 2 percent for tests to pass and shall be maintained until the concrete is poured. Tests shall be according to ASTM D1556 or D2922 and D3017.

Thickness: One random boring or test hole per 200 lineal feet of curb & gutter and one random boring or test hole per 200 lineal feet of sidewalk or fraction thereof. If sufficient inspection has been made by a City Engineer to verify required thickness, the City Engineer may waive thickness testing. No single measured thickness shall be less than the required thickness.

Testing documentation shall be according to Section 1.4 of these standards.

III ACCEPTANCE. The average of the two cylinders from the same concrete pour that are tested at 28 days shall equal or exceed the minimum specified 28-day compressive strength. If the average compressive strength of first two 28 day cylinder breaks is below specification the hold cylinder can also be broke at 28 days. The average compressive strength of any two of the 28 days breaks from the same concrete pour must then be above the specified compressive strength. If the average 28 day compressive strength from any two cylinders from the same concrete pour is below specification, the concrete will be rejected unless approved retests prove otherwise.

Concrete with a compressive strength below the required strength shall be evaluated by the City Engineer for capabilities necessary to the integrity of the structure. The City Engineer may accept this concrete under a special guarantee from the deliverer, or require that it be replaced with acceptable material. The City Engineer shall make the final decision. If additional tests are required to determine if strength tests are representative they shall be performed by coring in accordance with ASTM C 42 method or other acceptable non-destructive methods. The re-tested strength shall be the average of three cores (or other means). All costs incurred in re-sampling and retesting shall be paid by the developer.

Any curb, gutter or sidewalk base material determined not to be in compliance with these standards shall either be removed and replaced or re-worked until compliance is obtained. Any costs for testing re-work shall be paid for by the developer.

4.5 STREET LIGHTS: This section of the Standard defines the materials to be used and the requirements for installing street lights in City streets within Enoch City.

4.5.1 MATERIALS: Street light materials in Enoch City shall conform to the

following requirements:

I. LUMINARIES MATERIALS

- A. Materials: The fixture base, cage and cap shall be manufactured from cast aluminum. Cast plastics or composites will not be acceptable. All hardware shall be stainless steel with tamper resistant exterior hardware.
- B. Finish: The luminaries' body shall be finished with a premium quality thermoset polyester powder coat for durable finish. Color shall be as shown in Table 4.12.
- C. Pole Mounting: A 3" OD Tenon slip fitter shall allow mounting to pole with (6) 5/16" stainless steel socket set screws for local and commercial luminaries.
- D. Lens: Material shall be as shown in table 4.12.
- E. Performance: Lighting fixture shall meet or exceed IES standards for classification of Cutoff Luminaries. Less than 2.5% of lamp lumens shall be permitted above 90 degrees from nadir, and less than 10% of lamp lumens shall be permitted between 80 degrees and 90 degrees from nadir. Maximum vertical candela shall occur between 65 and 70 degrees with an IES type III distribution minimum.
- F. Reflector: Reflector assembly shall provide IES type III distribution with horizontal lamp configuration with lamp and reflector being completely concealed in top housing of fixture for local, industrial and interchange street lights. Reflector shall be manufactured from specular segmented aluminum sheet. Stamped hydro formed reflectors are not acceptable.
- G. Electrical: The ballast assembly and electrical components shall be accessible from hinged assembly allowing easy access to lamp and ballast replacement. Ballast shall have voltage and wattage ratings as shown in table 4.12. Socket assembly shall be 4KV pulse rated socketed. Quick disconnect clips shall be provided on all line wiring connections. A photo cell control shall be provided for each light, the photo cell shall be a twist-lock type.
- H. Luminaries: Fixtures shall be provided with lamps and as shown in the standard drawings.
- I. Fixture Manufacturer: The recommended manufacturers and model of fixtures shall be as shown in table 4.12 or approved equals.

- J. Options: Banner arms and sign mountings shall be available for local and commercial lights. House side shields shall be available for local lights.

**TABLE 4.12
STREET LIGHT FIXTURES**

Light Type	Type	Material	Color	Lens	Lamps					Model #
					Type	Volts	Maximum Lumens	Lamp Supplier OAE	Fixture Supplier OAE	
Local	Dark Sky	Cast Aluminum	Black	Clear Acrylic UV Protected	LED	120	4000	American Electric Lighting ATB0 Or ATB2 Or American Revolution Full Cutoff	American Electric Lighting ATB0 Or ATB2 Or American Revolution Full Cutoff	ATB0 20BLEDE5 3 MVOLT R3 3K P7 PCLL NL Or ATB0 20BLEDE1 0 MVOLT R3 3K P7 PCLL NL Or ATB0 30BLEDE1 3 MVOLT R3 3K P7 PCLL NL Or ATB2 60BLEDE8 5 MVOLT R3 3K P7 PCLL NL Or 247CL 20LEDE70 MVOLT 3K R3 P7 PCLL SS NL
Comm.	Decorative *	Cast Aluminum	Forest Green	Acrylic Refractor Globe UV Protected	LED	120	6500	Philips HADCO Lumilock GX2 LED (RL52)	Philips HADCO	Drawing # C9005 – DWGO2 cut off IES III or IV FB PCB RAL 6005
Industrial	Cobra	Cast Aluminum	Aluminum		LED	120	12,500	Halophane	Halophane	ATB2 60BLEDE7 0 MVOLT R4 PCLL

* Single fixture unless doubles are requested by City

II. POLE MATERIALS:

- A. Pole: Pole shafts shall be constructed as shown in table 4.13 and shall be full length heat treated and wind tunnel tested for appropriate wind load. Pole shafts shall be free of longitudinal welds. Pole dimensions shall be as shown in the standard drawings.
- B. Hand hole: The hand holes shall be a reinforced 2” X 4” per A87200 with lap-type cover and two stainless steel screw connections.
- C. Finish: The finish shall be Premium Thermoset Powder coat finish applied to the exposed pole shaft, electro-statically applied, oven cured and bonded at approximately 400 degrees to a minimum dry film thickness of 1 1/2 mils. Color shall be as shown in table 4.13. Cold tar epoxy, properly prepared and primed shall be applied to pole areas installed below grade.
- D. Cable Entry: Local street light poles shall have a 1 1/2” grommeted cable entry located 18” below grade, in line with the hand hole.
- E. Anti-Rotation: An anti-rotational device shall be provided on local street light poles by means of partial flattening the butt of the pole into an oval cross-section or other approved means.
- F. Grounding: An internal ground lug with 3/8” hole for attaching a grounding connector shall be provided opposite the hand hole on all poles.
- G. Pole Manufacturer: The recommended pole manufacturer and model of poles shall be as shown in table 4.13 or an approved equal.

**TABLE 4.13
STREET LIGHT POLES**

Location	Type	Material	Maximum Spacing	Color	Recommended Manufacturer O.A.E.	Model/ Drawing #
Local	Pedestal	Tapered Aluminum 0.125” Wall 6063-T6 Alloy	450 Feet	Black	Hapco Or Halophane	B88178 Or 1 800 3050 4TEA Special RFD 143538
Commercial	Decorative	Aluminum 0.250 Wall A319 & 6005-	450 Feet	Forest Green	Mountain States Lighting	15 EFA- Wash/L6- Cedar 5/12

		TS Alloys				
Industrial	Cobra	Round Tapered Steel 7 Gauge 55 KSI	450 Feet	Galvan- ized	Valmont Or Halophane	DS30-800 E 300-8S-GV (Breakaway Base) or RTS 30 GALV 8 Mast Slip Base

4.5.2 CONSTRUCTION METHODS AND EQUIPMENT

I. ASSEMBLY: All street lights, including pole and luminaire shall be assembled according to the manufacturer's instructions before raising the assembly to its final vertical position.

II. MOUNTING: All street lights, including pole and laminar shall be raised to its final vertical position with nylon slings without damage. Once vertical, the pole shall be direct buried or mounted to base according to the manufacturer's instructions and standard drawings. The final position of the street light shall have the pole in a plumb position with the luminaire lens facing the street being parallel to the curb. All photo cells shall face north.

III. ELECTRICAL CONNECTIONS: All electrical connections for street lights shall be accessible after the street light is in its final position with the connections conforming to the International Electrical Code.

IV. LOCATION AND SPACING: Unless designed to be installed on both sides of street, street lights should, when practical, be installed on the same side of the street and as close as possible to lot lines and street intersections while optimizing spacing and considering location of power source. The maximum spacing for streetlights shall be as shown in table 4.13. Unless otherwise approved, the base of the streetlight shall be at the back of sidewalk.

STANDARD
DETAILS

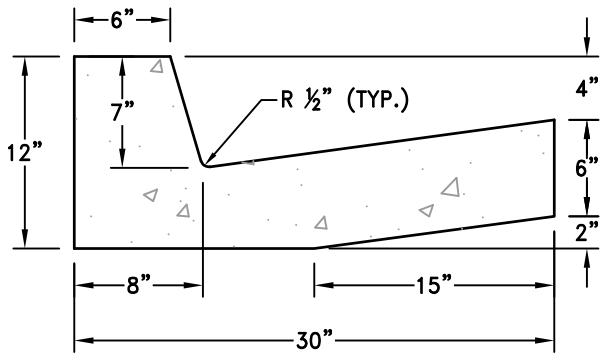

30" CURB & GUTTER – TYPE A
 0.57 YD.³ /10 LINEAR FT.
 N.T.S.

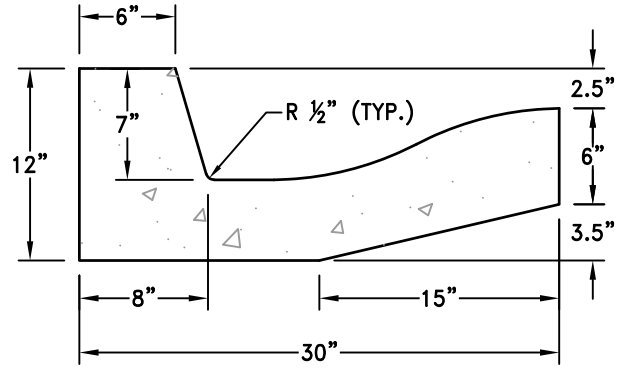

30" IRRIGATION CURB & GUTTER – TYPE B
 0.57 YD.³ /10 LINEAR FT.
 N.T.S.

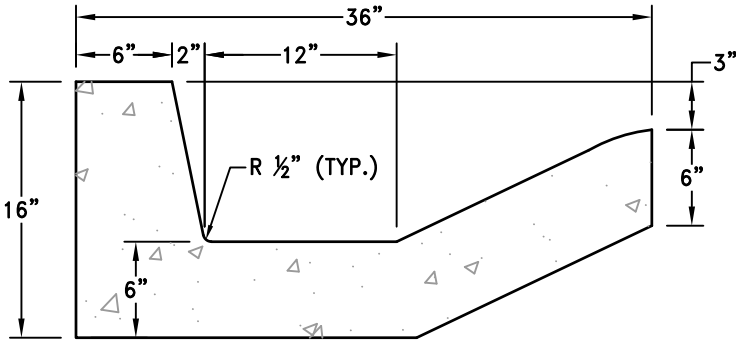

36" CURB & GUTTER – TYPE C
 0.81 YD.³ /10 LINEAR FT.
 N.T.S.

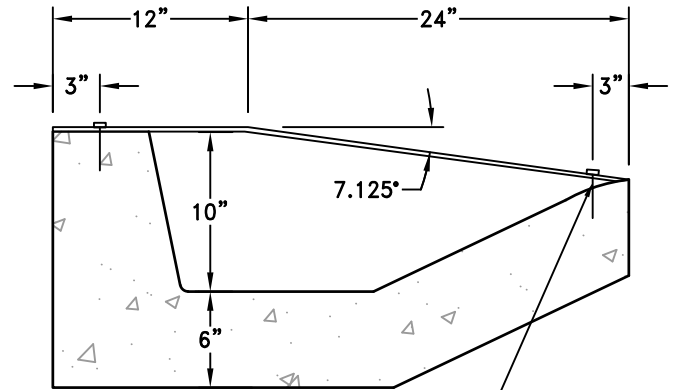

**1/2" x 4" ANCHOR BOLT (GALVANIZED)
 w/ 5/8" HOLE (SPACED 2' O/C & ON
 ALL CORNERS)**

COVERED DRIVE or SIDEWALK ACCESS RAMP*

USING 1/2" LARGE PATTERN INLAND 4-WAY PLATE (GALVANIZED
 PAINTED or HOT DIPPED) LENGTHS TO BE SAME AS DRIVEWAY or
 SIDEWALK WIDTHS

* USE ONLY WHEN APPROVED BY THE CITY ENGINEER.

NOTES:

ALL CURB AND GUTTER TYPES SHALL HAVE:

1. CONTRACTION JOINTS EVERY 10'0" O.C. 1/2" DEEP.
2. EXPANSION JOINTS AT THE P.C. AND P.T. OF A STREET INTERSECTION CURB RADIUS RETURN.



ENOCH CITY
 900 E MIDVALLEY RD
 Enoch, UT 84721
 Tel. (435) 586-1119

CURB & GUTTER

SCALE:
 N.T.S.
 DATE:
 DEC. 2022

DETAIL No.:

C1.1

SHEET:
 1 of 1

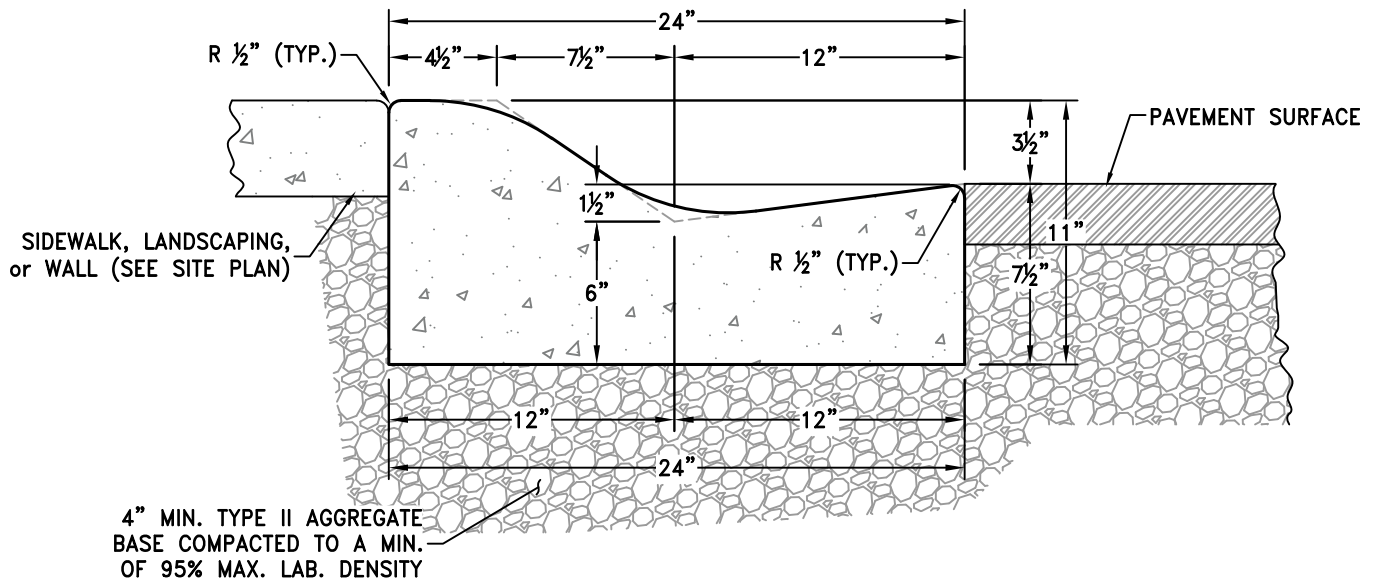

24" ROLL CURB & GUTTER – DETAIL A
N.T.S.

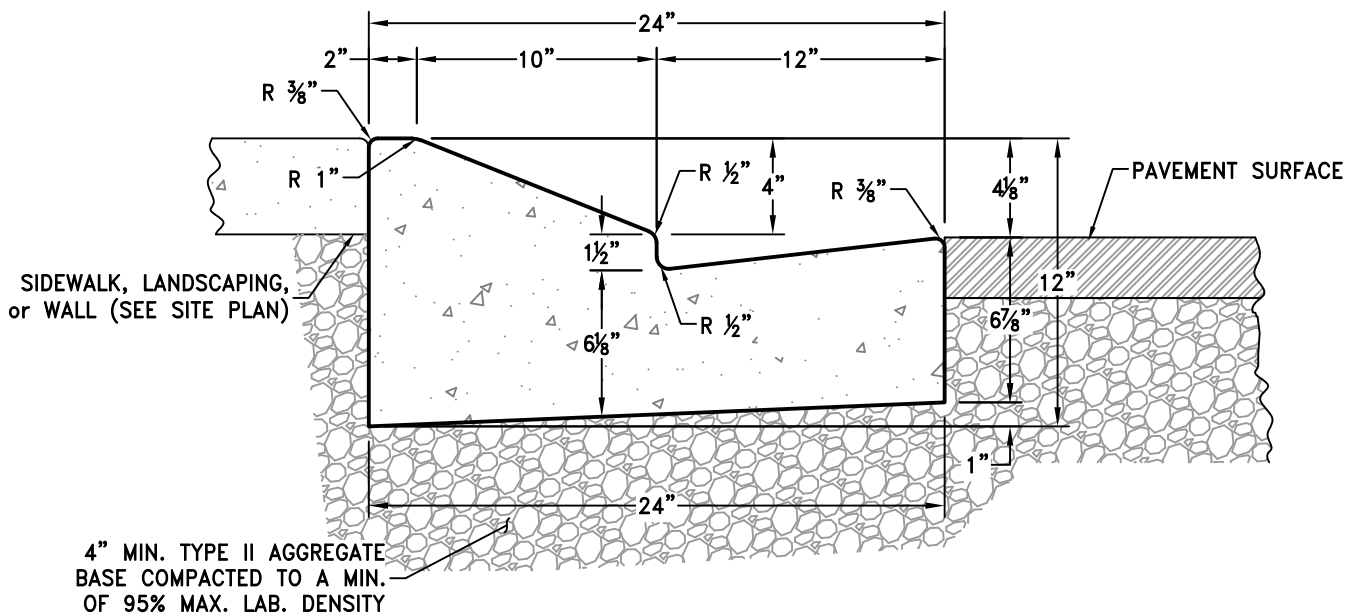

24" ROLL CURB & GUTTER – DETAIL B
N.T.S.

NOTES:

ALL CURB AND GUTTER TYPES SHALL HAVE:

1. CONTRACTION JOINTS EVERY 10'0" O.C. 1/2" DEEP.
2. EXPANSION JOINTS AT THE P.C. AND P.T. OF A STREET INTERSECTION CURB RADIUS RETURN.



ENOCH CITY
900 E MIDVALLEY RD
Enoch, UT 84721
Tel. (435) 586-1119

**ROLL CURB &
GUTTER**

SCALE:
N.T.S.
DATE:
DEC. 2022

DETAIL No.:

C1.2

SHEET:
1 of 1

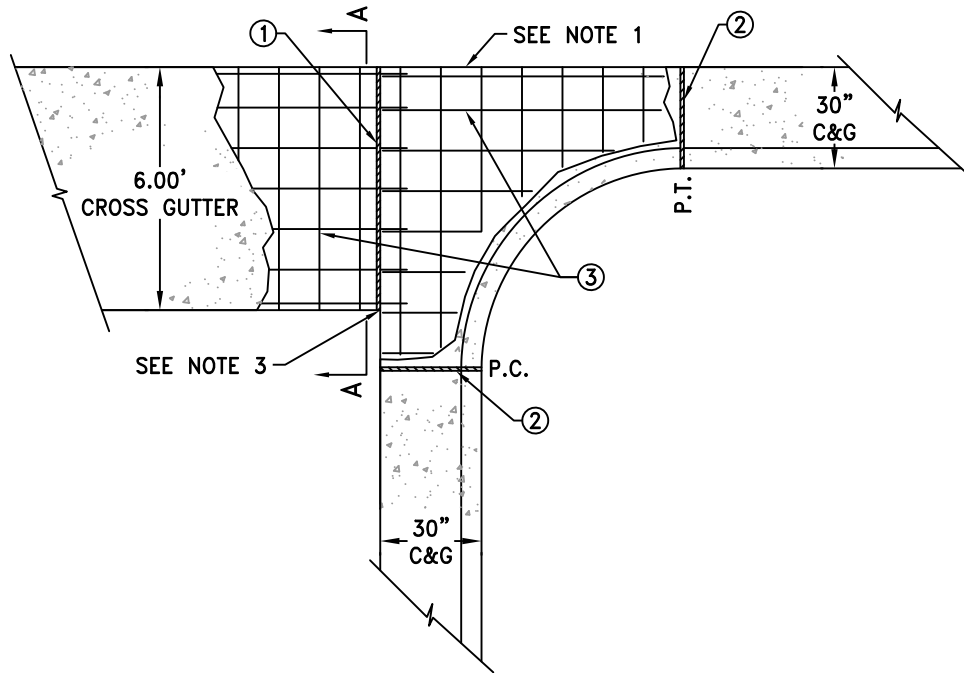

PLAN VIEW
N.T.S.

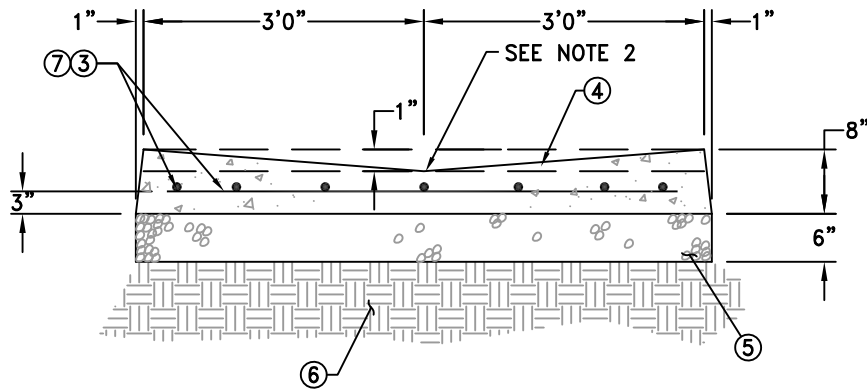

SECTION B-B
N.T.S.

NOTES:

1. TRANSITION LIP OF CURB THROUGH APRON TO ACHIEVE 1" CROSS GUTTER DEPTH.
2. CROSS GUTTER FLOW LINE GRADE TO BE CONSTANT FROM CURB AND GUTTER ELEVATIONS AT EACH END.
3. ONLY 90° CORNERS WILL BE ALLOWED WHERE ASPHALT CONNECTS TO CROSS GUTTER. CONCRETE APRONS MAY BE REQUIRED.

CONSTRUCTION NOTES:

- ① CONTRACTION JOINT SPACED AT 10'0" MAX. O.C. THRU CROSS GUTTER
- 1/2" EXPANSION JOINT.
- ② #4 BARS @ 12" O.C. BOTH WAYS
- ③ STANDARD.
- CLASS A CONCRETE.
- ④ AGGREGATE BASE.
- ⑤ COMPACTED SUBGRADE.
- ⑥ REBAR MATS TO BE SUPPORTED ON DOBIE BLOCKS or REBAR CHAIRS. SPACE EVERY 4'0" O.C. BOTH WAYS.
- ⑦



ENOCH CITY
900 E MIDVALLEY RD
Enoch, UT 84721
Tel. (435) 586-1119

6'0" CROSS GUTTER

SCALE:
N.T.S.
DATE:
DEC. 2022

DETAIL No.:

C2.0

SHEET:
1 of 1

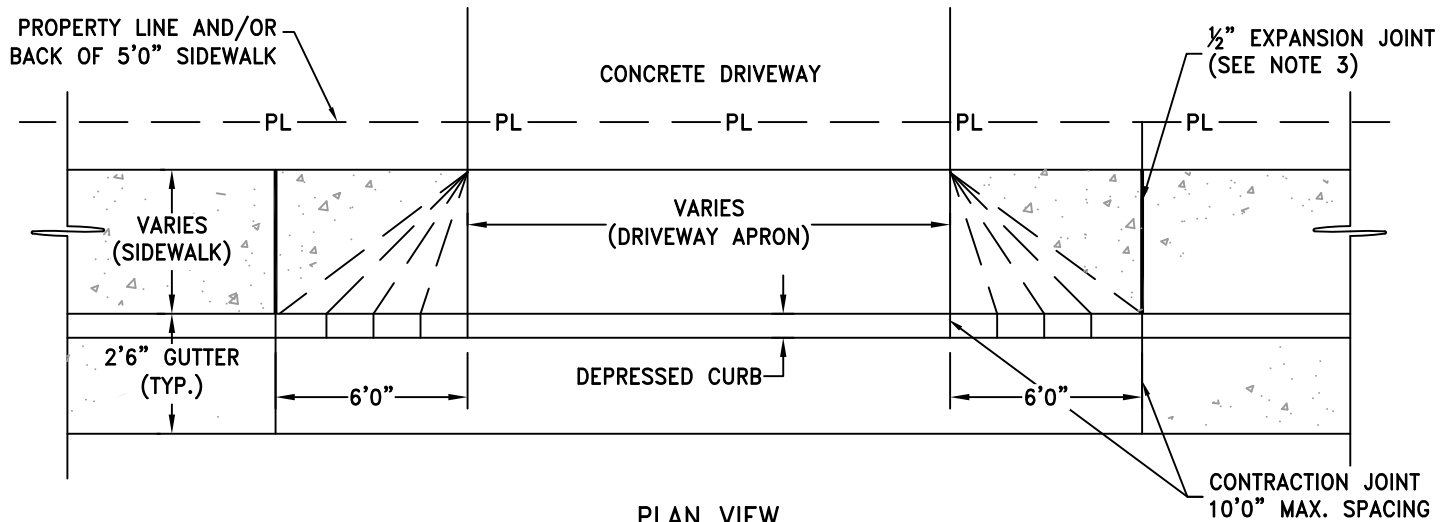

PLAN VIEW
N.T.S.

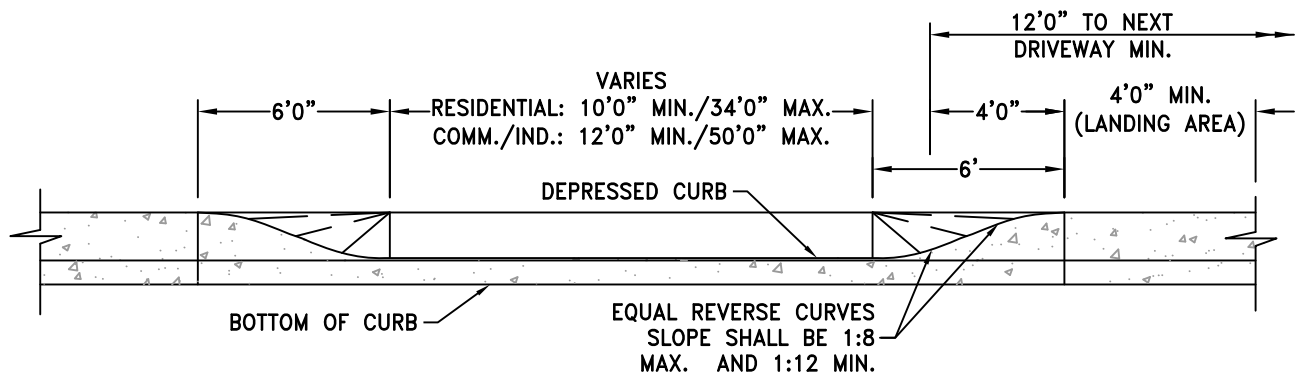

ELEVATION
N.T.S.

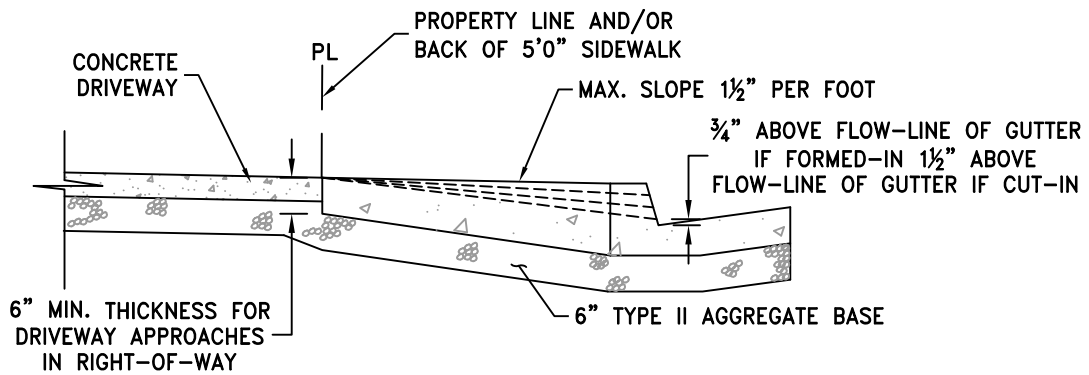

SECTION
N.T.S.

NOTES:

1. #4 BARS @ 16" O.C. BOTH WAYS REQUIRED ON COMMERCIAL & INDUSTRIAL DRIVEWAYS.
2. DRIVEWAY CUTS IN EXISTING CURBS SHALL BE SAW CUT TO DIMENSIONS SHOWN, BREAKING-OFF OF CURB BACKS WILL NOT BE PERMITTED.
3. 40' EXPANSION JOINT SPACING IN SIDEWALKS TO CONTINUE THROUGH DRIVEWAYS.
4. ALL CONCRETE TO BE CLASS B (4000 PSI).



ENOCH CITY
900 E MIDVALLEY RD
Enoch, UT 84721
Tel. (435) 586-1119

DRIVEWAYS

SCALE:
N.T.S.
DATE:
DEC. 2022

DETAIL No.:

C3.0

SHEET:
1 of 1

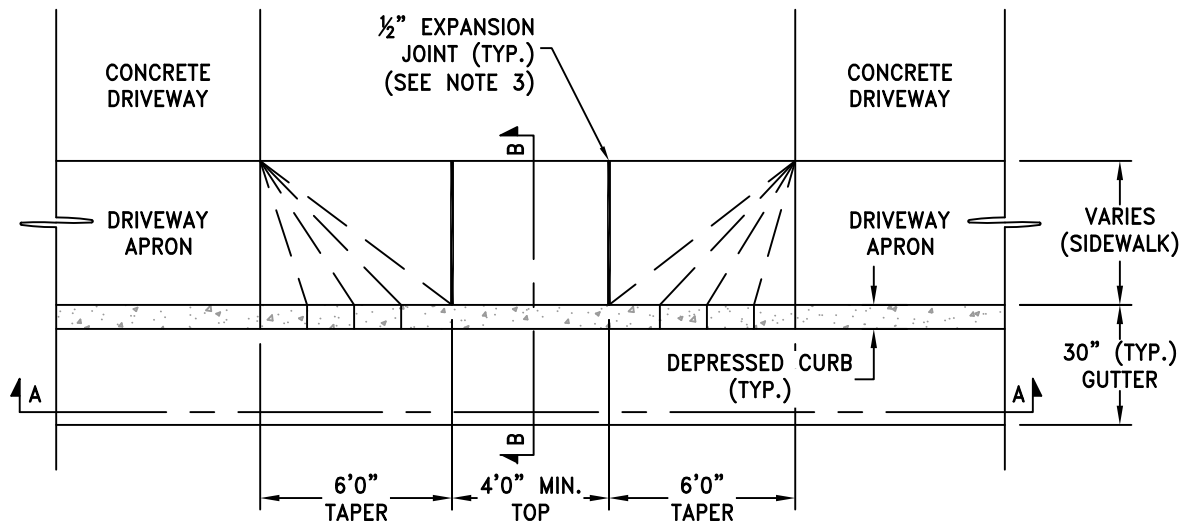

PLAN VIEW
N.T.S.

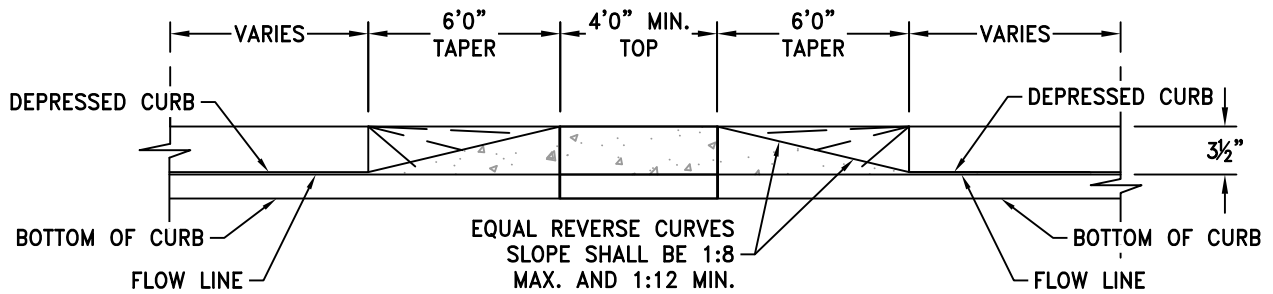

SECTION A-A
N.T.S.

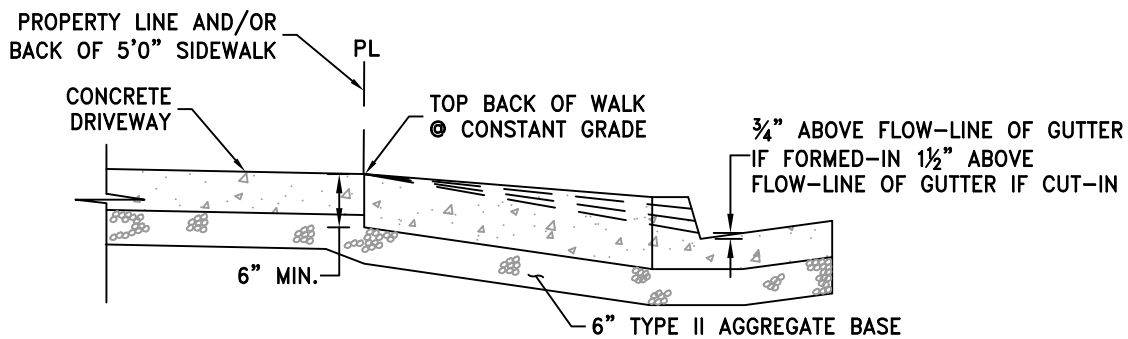

SECTION B-B
N.T.S.

NOTES:

1. #4 BARS @ 16" O.C. BOTH WAYS REQUIRED ON COMMERCIAL & INDUSTRIAL DRIVEWAYS.
2. DRIVEWAY CUTS IN EXISTING CURBS SHALL BE SAW CUT TO DIMENSIONS SHOWN, BREAKING-OFF OF CURB BACKS WILL NOT BE PERMITTED.
3. 40' EXPANSION JOINT SPACING IN SIDEWALKS TO CONTINUE THROUGH DRIVEWAYS.
4. ALL CONCRETE TO BE CLASS B (4000 PSI).

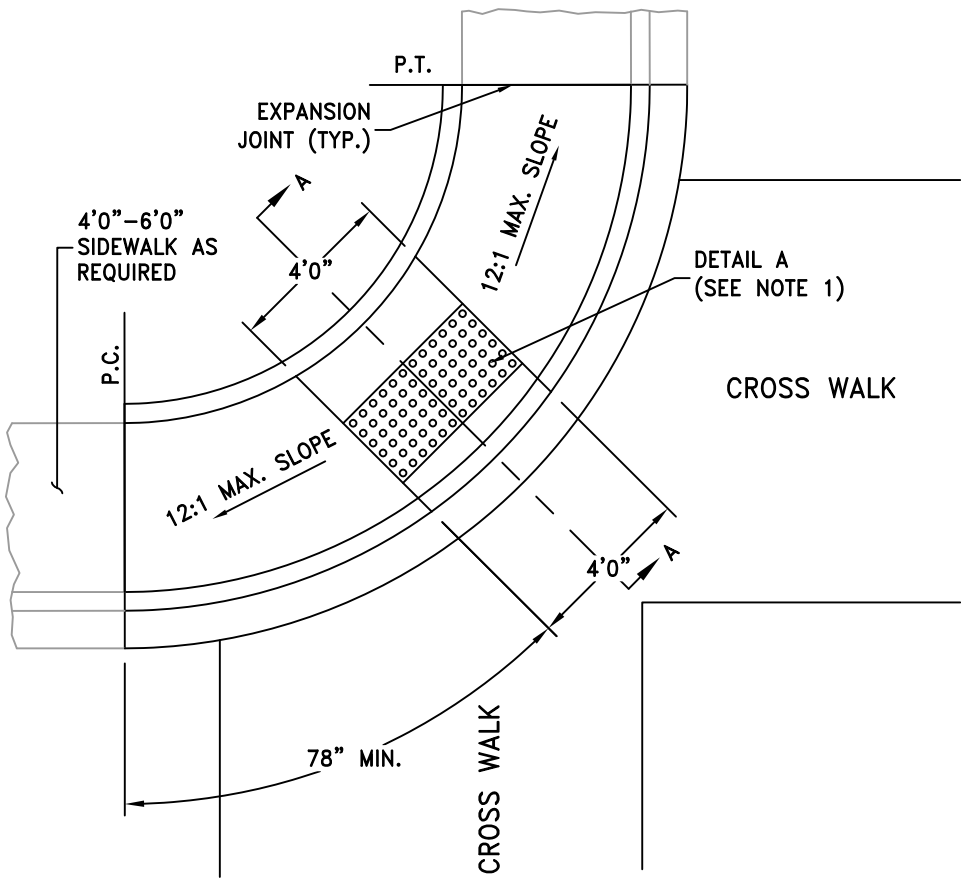

PLAN VIEW
N.T.S.

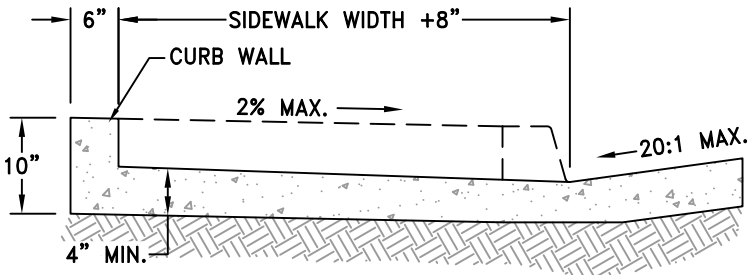

SECTION A-A
N.T.S.

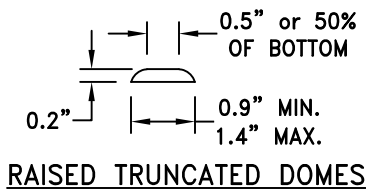

RAISED TRUNCATED DOMES

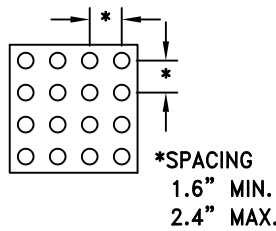

DETAIL A
N.T.S.

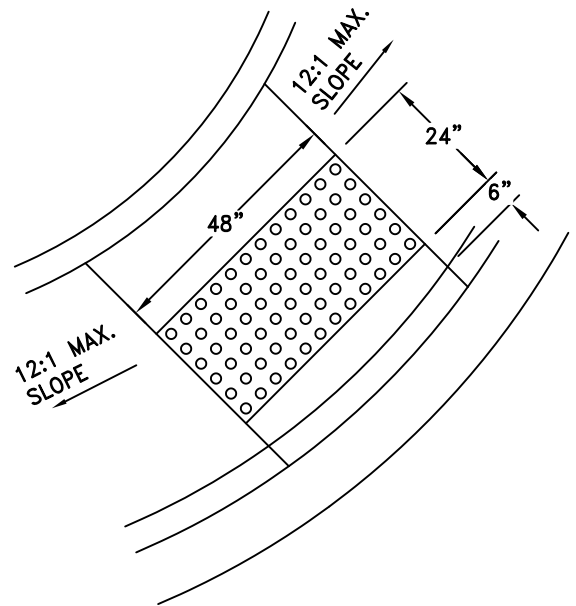

NOTES:

1. DETECTABLE WARNING CAST-IN-PLACE SYSTEM WITH TRUNCATED DOMES BY AMOR-TILE O.A.E. 24"x48" SIZE, BRICK RED COLOR O.A.E.
2. WHEELCHAIR RAMPS SHALL BE LOCATED AT THE MIDPOINT OF CURB RADIUS UNLESS OTHERWISE INDICATED ON PLAN.
3. RAMPS SHALL BE CONSTRUCTED WITH A ROUGH BROOM FINISH TRANSVERSE TO THE SLOPE.
4. ALL CONCRETE TO BE CLASS A.



ENOCH CITY
900 E MIDVALLEY RD
Enoch, UT 84721
Tel. (435) 586-1119

ACCESSIBLE RAMP

SCALE:
N.T.S.
DATE:
DEC. 2022

DETAIL No.:

C5.0

SHEET:
1 of 1

NOTES:

1. ON ALL CURB RETURNS EXPANSION JOINTS SHALL BE PLACED AT P.C. AND P.T. OF THE SIDEWALK.
2. ANY REPLACED SECTIONS OF SIDEWALK SHALL HAVE AN EXPANSION JOINT INSTALLED TO MAINTAIN THE 40'0" MAX. SPACING.

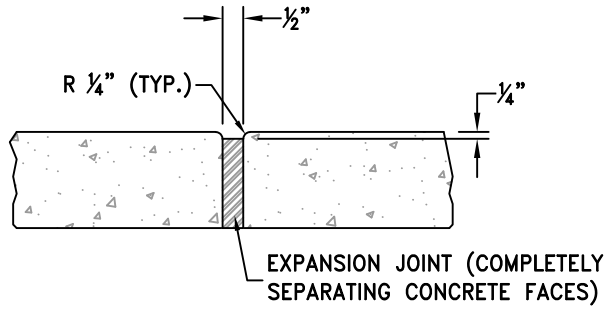

EXPANSION JOINT
N.T.S.

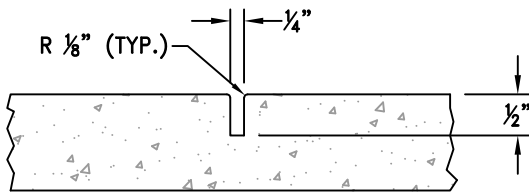

CONNECTION JOINT
N.T.S.

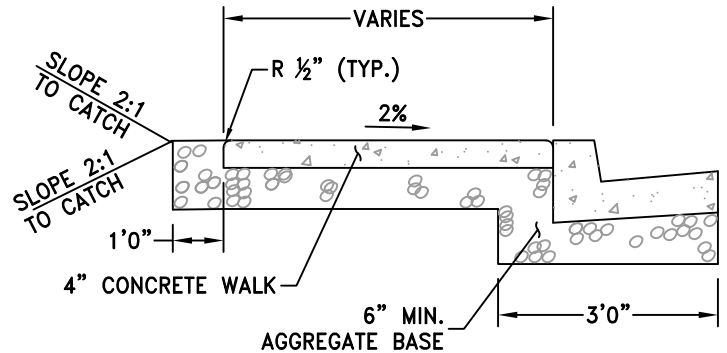

TYPICAL SECTION
N.T.S.

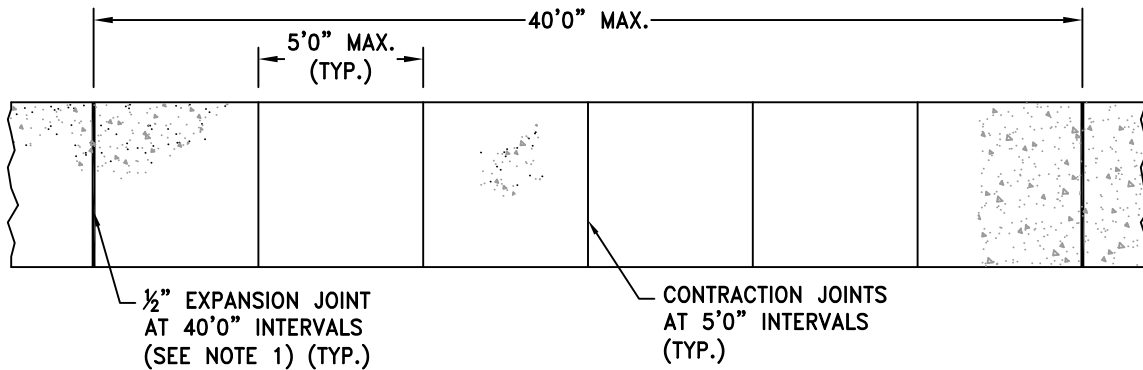

PLAN VIEW
N.T.S.

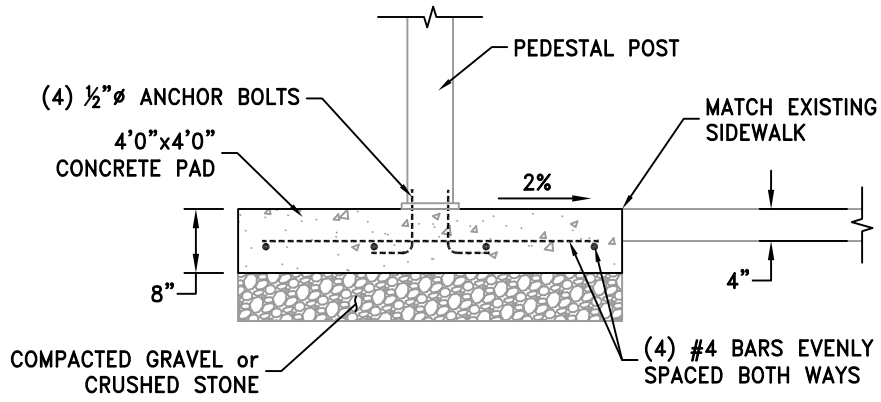

PROFILE VIEW
N.T.S.

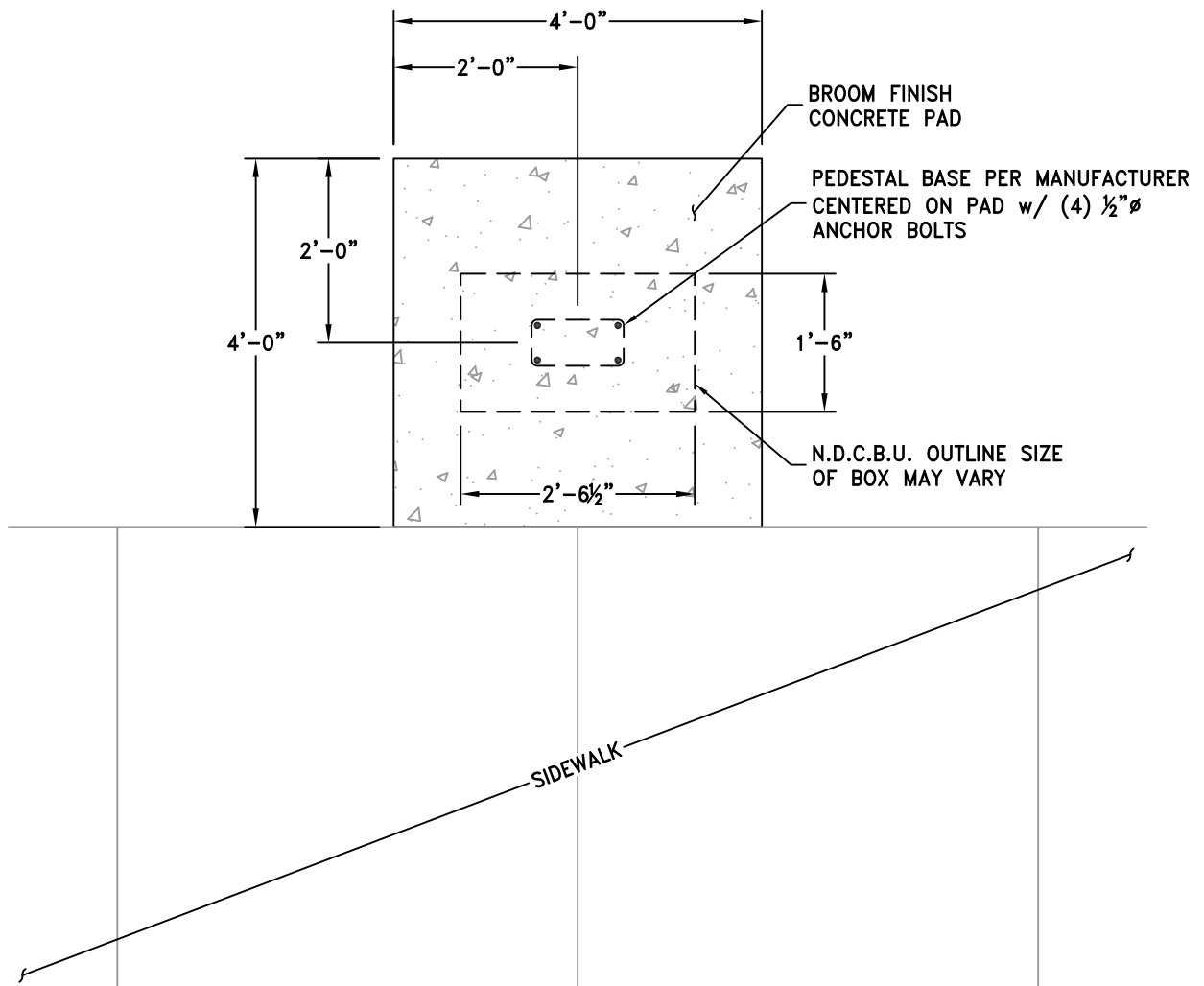

PLAN VIEW
N.T.S.



ENOCH CITY
900 E MIDVALLEY RD
Enoch, UT 84721
Tel. (435) 586-1119

**CONCRETE PAD FOR
MAILBOX
DETAIL**

SCALE:
N.T.S.
DATE:
DEC. 2022

DETAIL No.:

C7.0

SHEET:
1 of 1

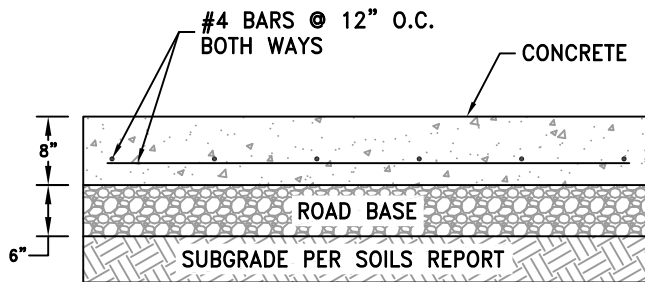
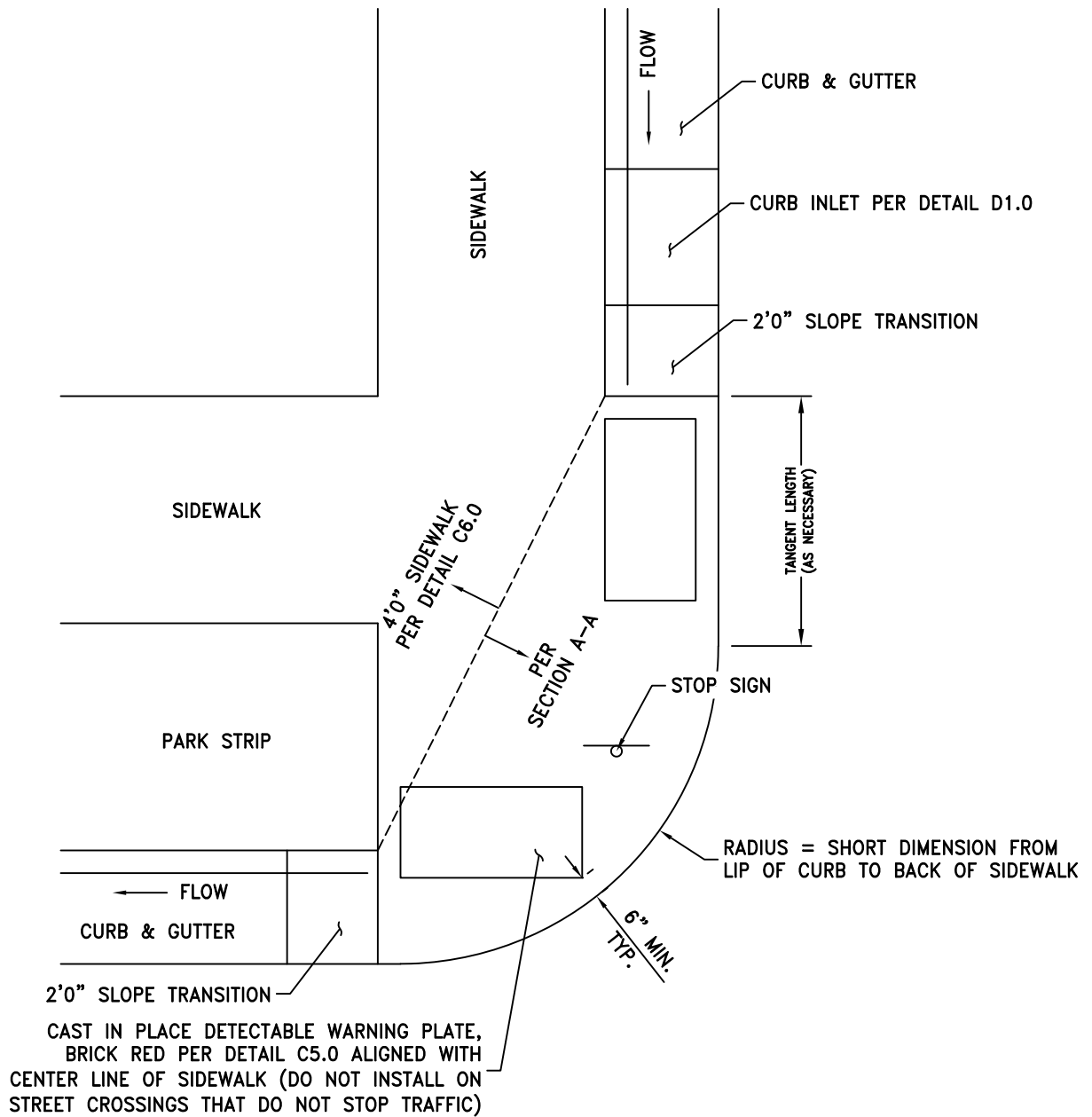

NOTES:

1. FALSE RADIUS ONLY ALLOWED WHERE APPROVED BY CITY ENGINEER.
2. CURB & GUTTER TO FLOW AWAY FROM FALSE RADIUS UNLESS STORM WATER FLOW IS ROUTED INTO A STORM DRAIN VIA A CURB INLET BOX AS SHOWN.
3. FALSE RADIUS TO BE ADAPTED TO CONDITION IN FIELD AS APPROVED BY CITY ENGINEER.

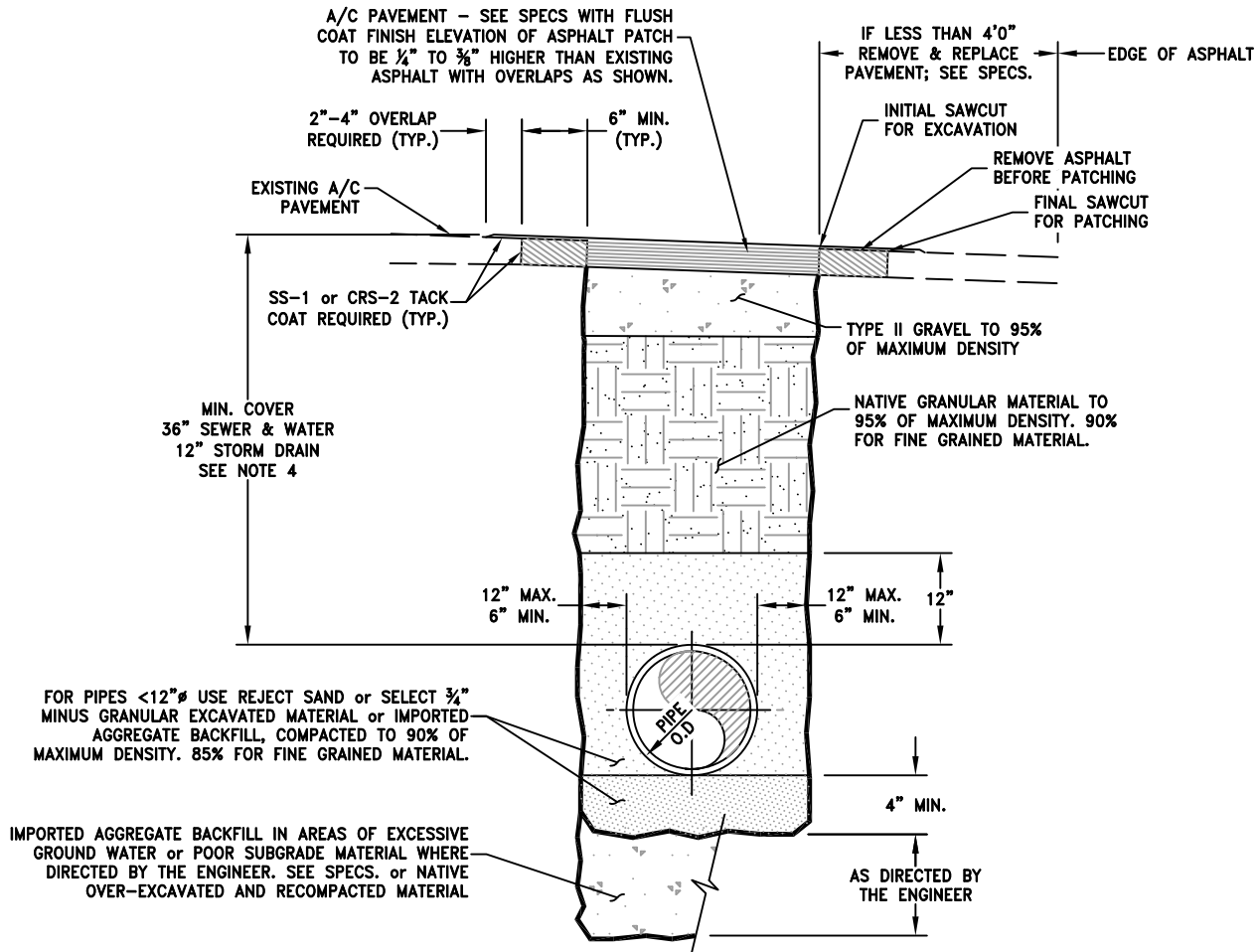





TYPICAL PAVED TRENCH DETAIL
N.T.S.

NOTES:

1. THIS DETAIL APPLIES TO THE INSTALLATION OF ALL SERVICE LATERALS. TRENCH WIDTH MINIMUMS DO NOT APPLY TO LATERALS LESS THAN 4".
2. IF PROFILE DRAWING OF THE PIPE IS PROVIDED, THE COVER SHALL BE AS SHOWN ON PROFILE SHEET.
3. TRENCH SIDE SLOPES AND/OR SHORING SHALL COMPLY w/ OSHA STANDARDS.
4. FOR HDPE PIPE WITH LESS THAN 12" COVER USE FLOWABLE FILL TO BOTTOM OF ASPHALT FROM BOTTOM OF PIPE.
5. MINIMUM DEPTH OF SEWER MANHOLE IS 48" OF COVER OVER TOP OF THE PIPE UNLESS OTHERWISE APPROVED BY ENOCH CITY.

LEGEND

-  FINAL BACKFILL (MATERIAL AS SHOWN)
-  PIPE ZONE
-  BEDDING
-  FOUNDATION



ENOCH CITY
900 E MIDVALLEY RD
Enoch, UT 84721
Tel. (435) 586-1119

**EARTH FILLED
TRENCH SECTION**

SCALE:
N.T.S.
DATE:
DEC. 2022

DETAIL No.:



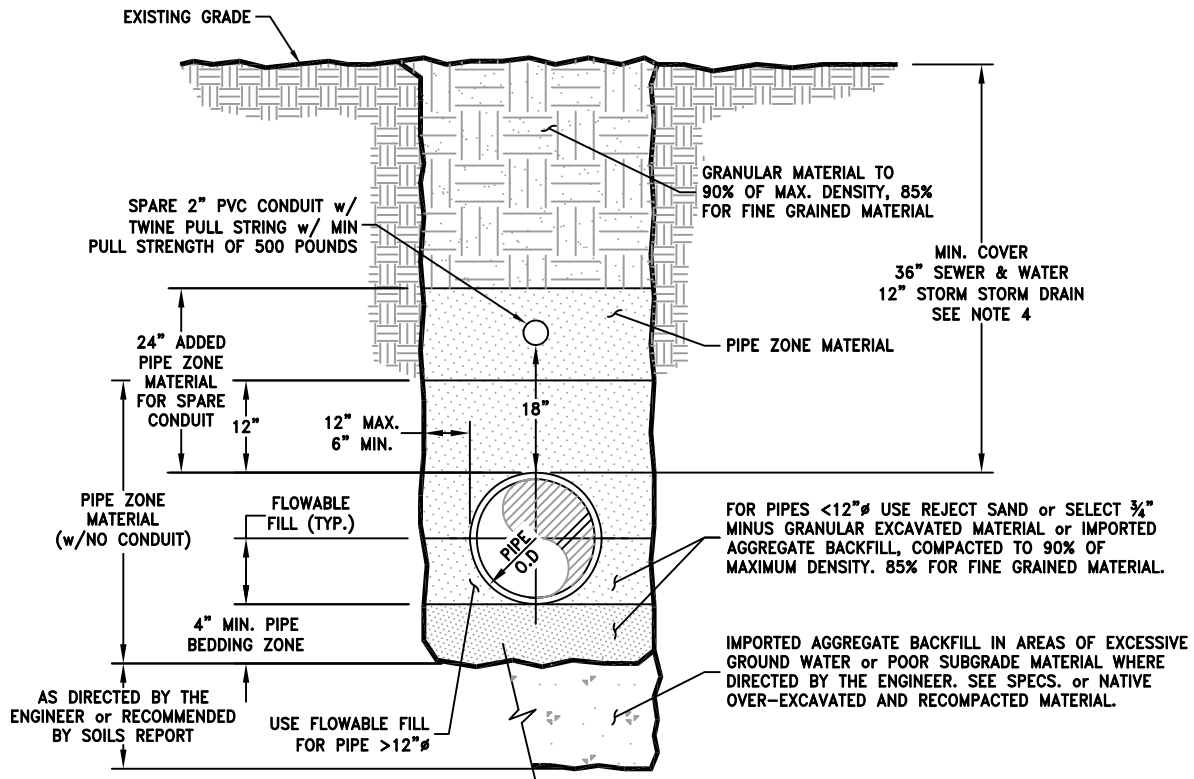

R1.1A

SHEET:
1 of 2



TYPICAL UNPAVED TRENCH DETAIL
N.T.S.

LEGEND

-  FINAL BACKFILL (MATERIAL AS SHOWN)
-  PIPE ZONE
-  BEDDING
-  FOUNDATION

NOTES:

1. THIS DETAIL APPLIES TO THE INSTALLATION OF ALL SERVICE LATERALS. TRENCH WIDTH MINIMUMS DO NOT APPLY TO LATERALS LESS THAN 4".
2. IF PROFILE DRAWING OF THE PIPE IS PROVIDED, THE COVER SHALL BE AS SHOWN ON PROFILE SHEET.
3. TRENCH SIDE SLOPES AND/OR SHORING SHALL COMPLY W/ OSHA STANDARDS.
4. FOR HDPE PIPE WITH LESS THAN 12" COVER USE FLOWABLE FILL TO BOTTOM OF ASPHALT FROM BOTTOM OF PIPE.
5. MINIMUM DEPTH OF SEWER MANHOLE IS 48" OF COVER OVER TOP OF THE PIPE UNLESS OTHERWISE APPROVED BY ENOCH CITY.



ENOCH CITY
900 E MIDVALLEY RD
Enoch, UT 84721
Tel. (435) 586-1119

**EARTH FILLED
TRENCH SECTION**

SCALE:
N.T.S.
DATE:
DEC. 2022

DETAIL No.:

R1.1B

SHEET:
2 of 2

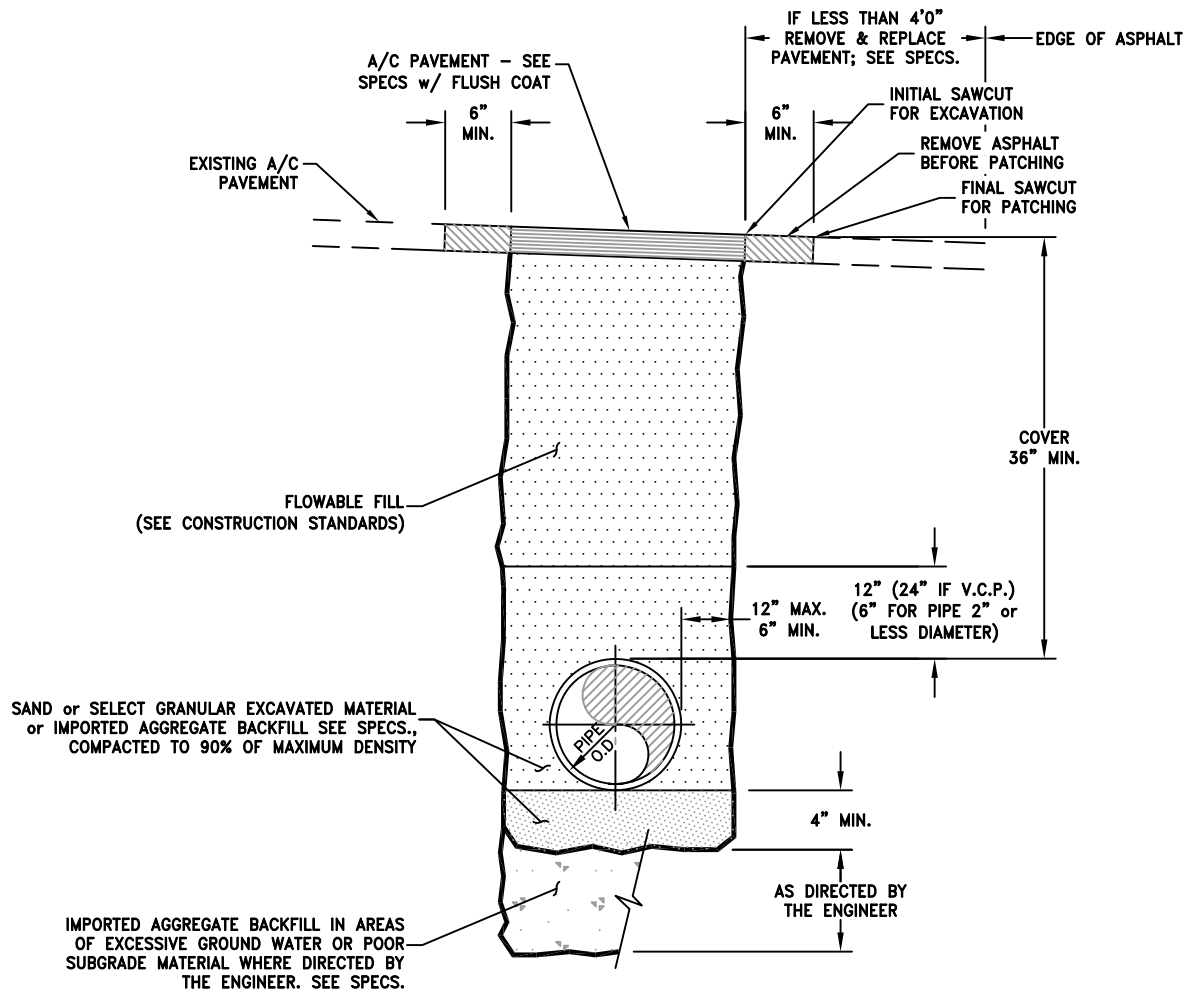

TYPICAL TRENCH DETAIL
N.T.S.

NOTES:

1. TRENCH WIDTH, BEDDING, AND PIPE ZONE REQUIREMENTS FOR UTILITY INSTALLATIONS SHALL CONFORM TO THE RESPECTIVE AGENCY REQUIREMENTS.
2. TRENCH SIDE SLOPES AND/OR SHORING SHALL COMPLY WITH OSHA STANDARDS.

 <p>ENOCH CITY 900 E MIDVALLEY RD Enoch, UT 84721 Tel. (435) 586-1119</p> <p>Copyright © 2023</p>	<p>SLURRY FILLED TRENCH SECTION</p>	<p>SCALE: N.T.S.</p> <p>DATE: DEC. 2022</p> <p>DETAIL No.: R1.2</p> <p>SHEET: 1 of 1</p>
---	--	---

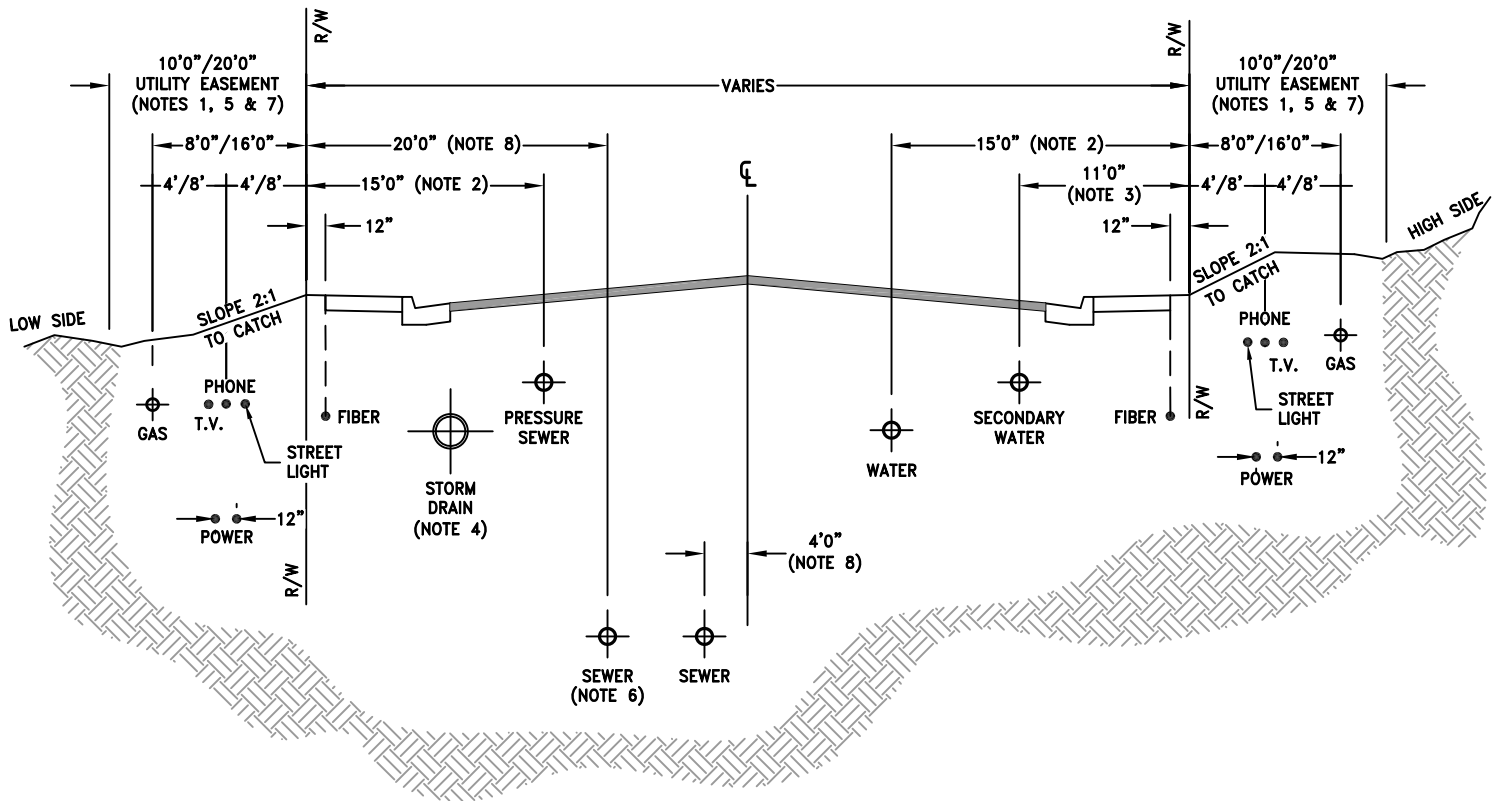

NOTES:

1. UTILITY EASEMENTS MUST BE PREPARED BY DEVELOPER TO RECEIVE UTILITIES.
2. 21'0" IF TRAIL EXISTS.
3. 17'0" IF TRAIL EXISTS.
4. LOCATE STORM DRAIN UNDER LIP OF CURB.
5. 10'0" IN RESIDENTIAL AREAS / 20'0" IN INDUSTRIAL & COMMERCIAL AREAS.
6. OPTIONAL FOR ARTERIALS AND MAJOR COLLECTORS ONLY.
7. ALL UTILITIES HAVE THE OPTION OF USING THE REAR LOT EASEMENT.
8. MEASURED AT CENTER OF MANHOLES.
9. MINIMUM REQUIRED SEPARATION BETWEEN WATER AND SEWER IS 10 FEET.

MINIMUM DEPTHS	
WATER	36"
TELEPHONE	30"
POWER	40"
GAS	30"
SEC. WATER	24"
SAN. SEWER	9'0"
STORM DRAIN	-
TELEVISION	30"
FIBER	30"



ENOCH CITY
 900 E MIDVALLEY RD
 Enoch, UT 84721
 Tel. (435) 586-1119

UTILITY LOCATION

SCALE:
 N.T.S.
 DATE:
 DEC. 2022

DETAIL No.:

R2.0

SHEET:
 1 of 1

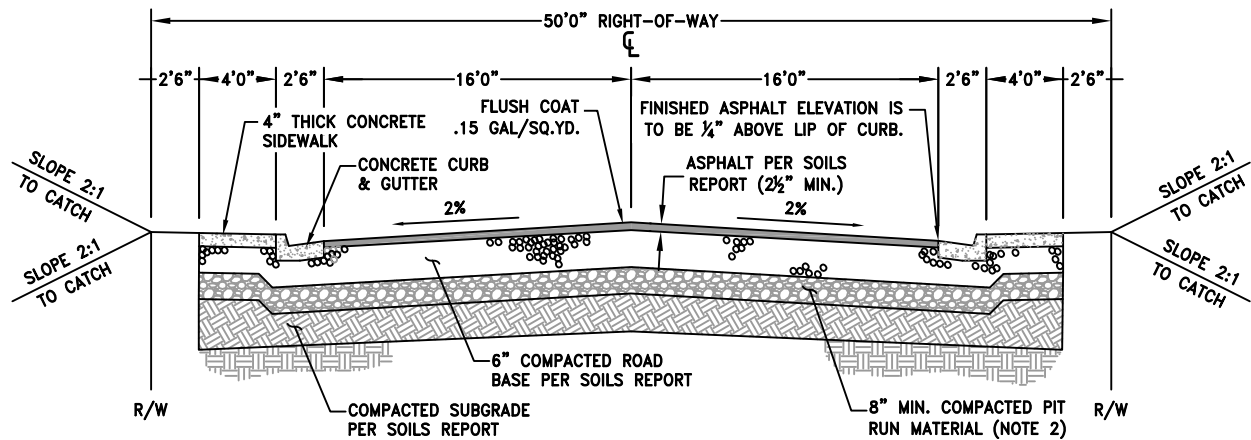

TYPICAL ROAD SECTION – 50'0" RIGHT-OF-WAY
N.T.S.

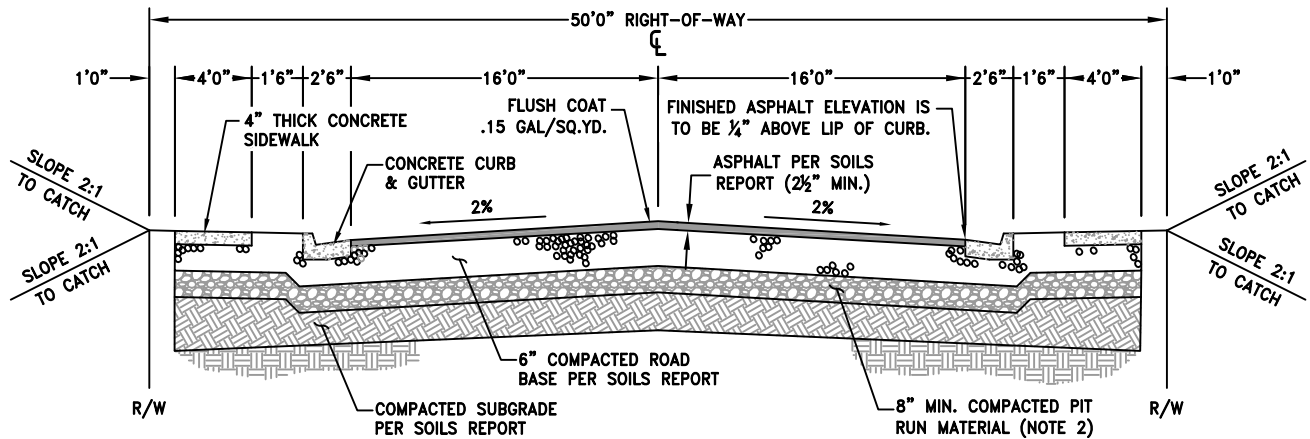

TYPICAL ROAD SECTION – 50'0" RIGHT-OF-WAY
N.T.S.

NOTES:

1. BACK OF SIDEWALK TO BE BACKFILLED TO TOP OF CONCRETE.
2. PIT RUN MATERIAL CAN BE ELIMINATED IF NATIVE MATERIAL MEETS OR EXCEEDS PIT RUN MATERIAL STANDARD GRADATION.



ENOCH CITY
900 E MIDVALLEY RD
Enoch, UT 84721
Tel. (435) 586-1119

TYPICAL 50'0" ROAD SECTION

SCALE:
N.T.S.
DATE:
APR. 2024

DETAIL No.:

R3.1

SHEET:
1 of 1

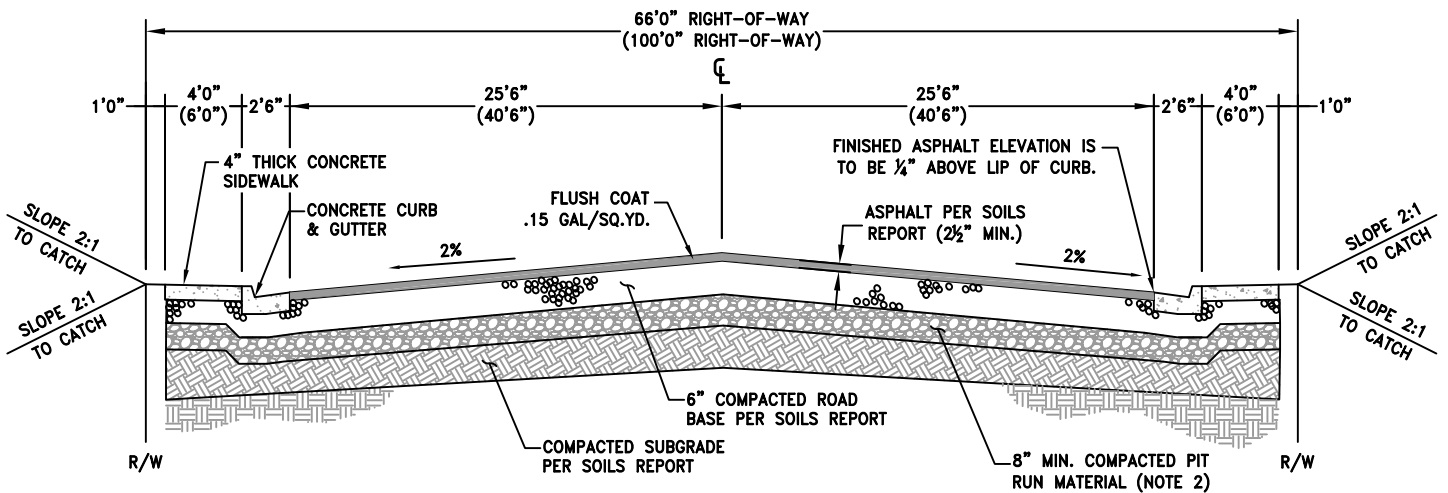

TYPICAL ROAD SECTION - 66'0" & 100'0" RIGHT-OF-WAYS
N.T.S.

NOTES:

1. BACK OF SIDEWALK TO BE BACKFILLED TO TOP OF CONCRETE.
2. PIT RUN MATERIAL CAN BE ELIMINATED IF NATIVE MATERIAL MEETS OR EXCEEDS PIT RUN MATERIAL STANDARD GRADATION.



ENOCH CITY
900 E MIDVALLEY RD
Enoch, UT 84721
Tel. (435) 586-1119

TYPICAL 66'0" &
100'0" ROAD
SECTIONS

SCALE:
N.T.S.
DATE:
DEC. 2022

DETAIL No.:

R3.2

SHEET:
1 of 1

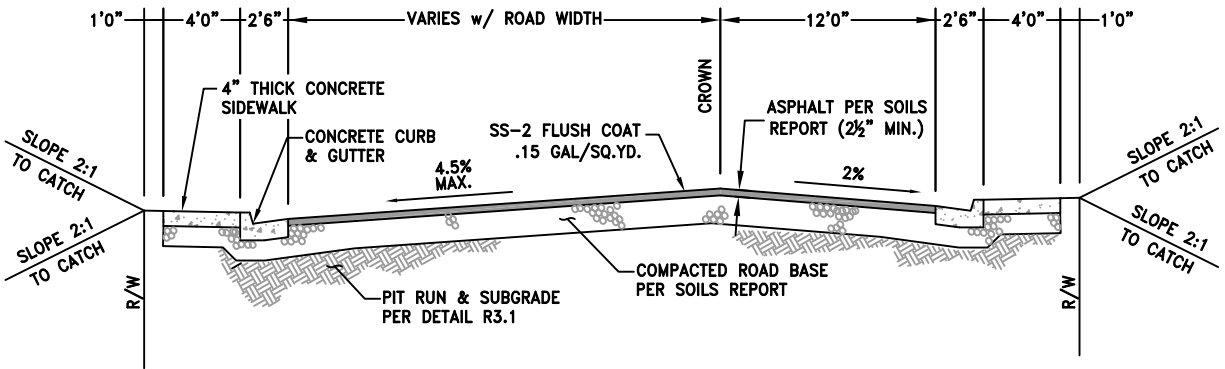

TYPICAL ROAD SECTION w/ CROSS SLOPE
N.T.S.

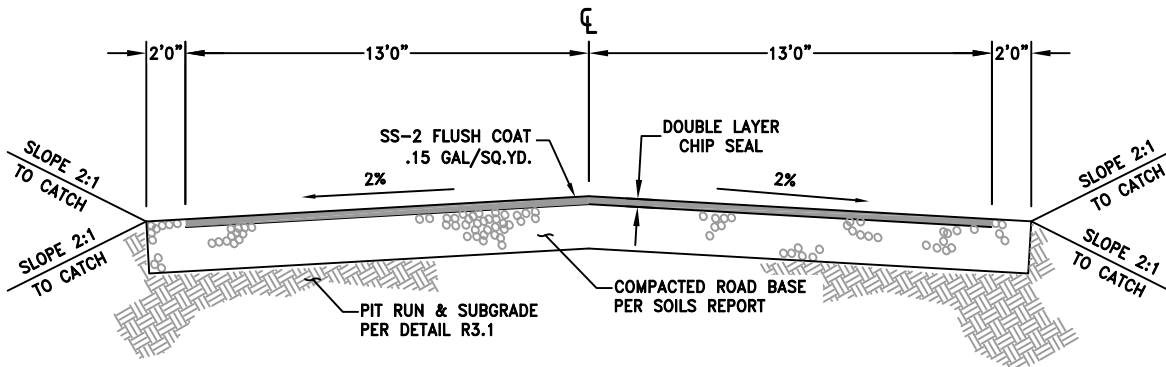

TYPICAL ROAD SECTION FOR TEMPORARY SECONDARY ACCESS
N.T.S.

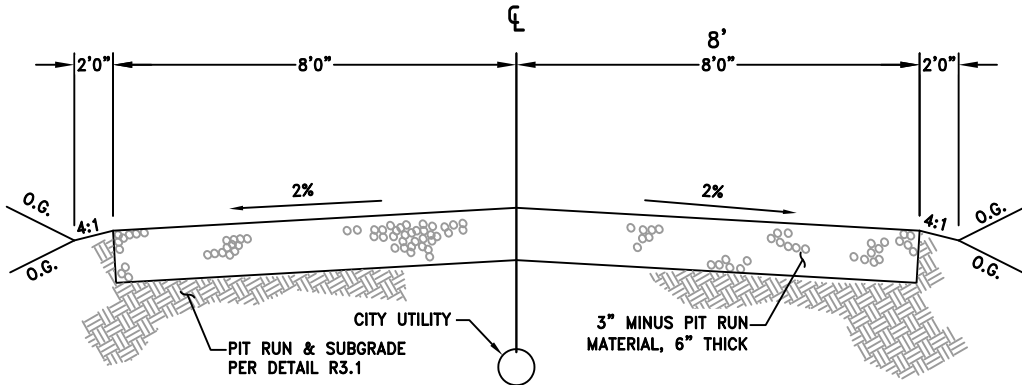

TYPICAL ROAD SECTION FOR TEMPORARY CITY MAINTENANCE ACCESS
N.T.S.

NOTES:

1. BACK OF SIDEWALK TO BE BACKFILLED TO TOP OF CONCRETE.
2. PIT RUN MATERIAL CAN BE ELIMINATED IF NATIVE MATERIAL MEETS OR EXCEEDS PIT RUN MATERIAL STANDARD GRADATION.



ENOCH CITY
900 E MIDVALLEY RD
Enoch, UT 84721
Tel. (435) 586-1119

SPECIAL ROAD SECTIONS

SCALE:
N.T.S.
DATE:
DEC. 2022

DETAIL No.:

R3.3

SHEET:
1 of 1

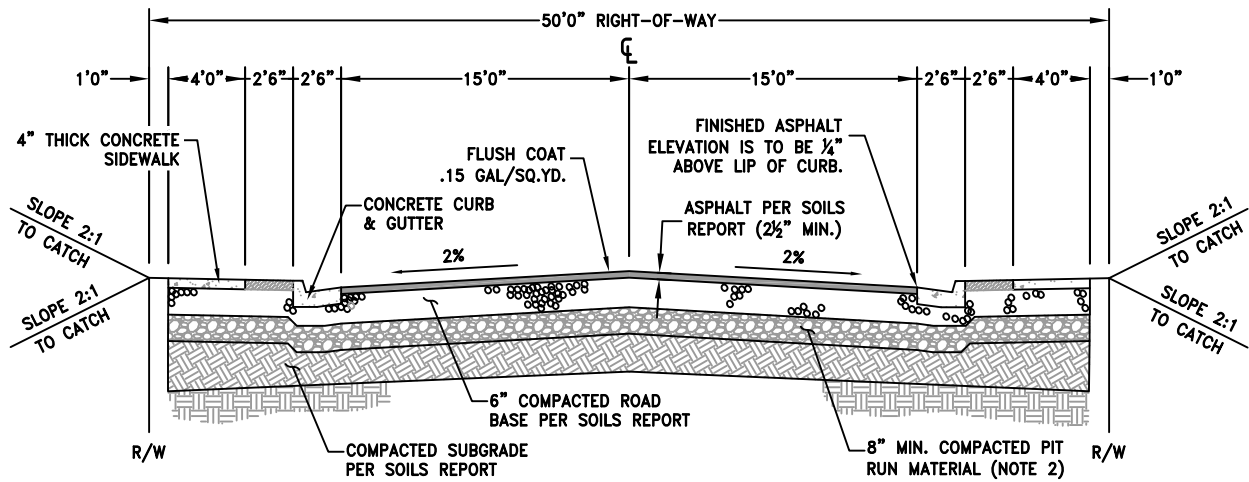

TYPICAL ROAD SECTION - 50'0" RIGHT-OF-WAY
N.T.S.

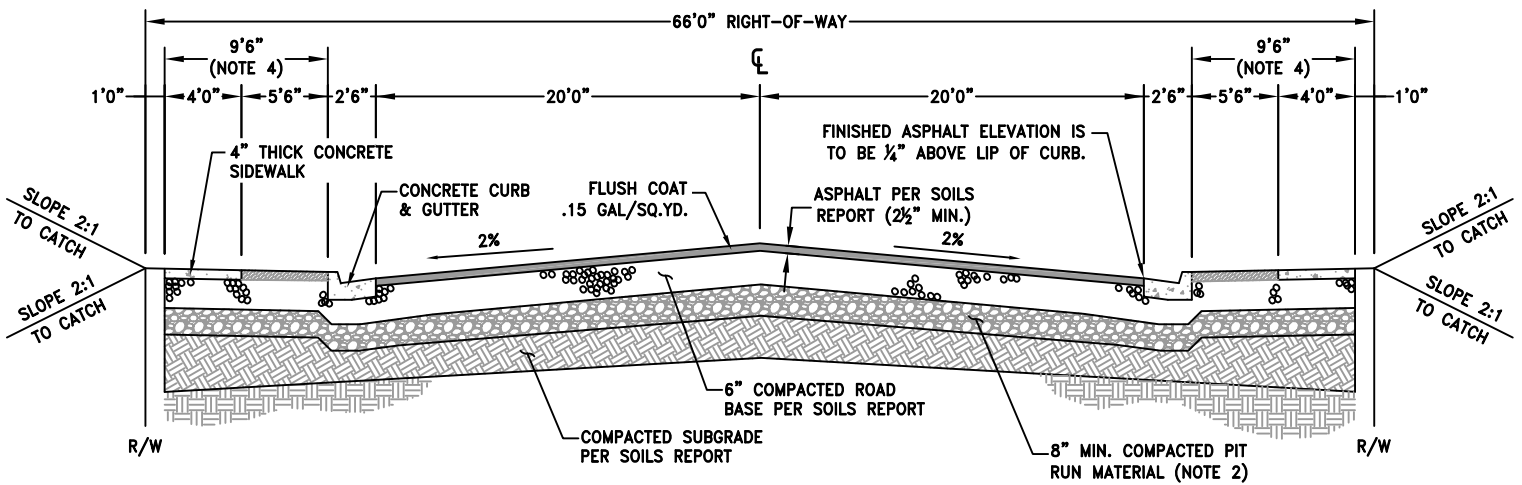

PLANTER STRIP ROAD SECTION - 66'0" RIGHT-OF-WAY
N.T.S.

NOTES:

1. BACK OF SIDEWALK TO BE BACKFILLED TO TOP OF CONCRETE.
2. PIT RUN MATERIAL CAN BE ELIMINATED IF NATIVE MATERIAL MEETS OR EXCEEDS PIT RUN MATERIAL STANDARD GRADATION.
3. VEGETATION FOR PLANTER STRIP LANDSCAPING TO FOLLOW APPROVED ENOCH CITY VEGETATION ORDINANCE.
4. SIDEWALK MAY MEANDER WITHIN THE ALLOWABLE SPACE PROVIDED. A MINIMUM 4'0" SIDEWALK WIDTH MUST BE MAINTAINED.
5. PLANTER STRIP TO BE MAINTAINED BY PROPERTY OWNER.
6. 24" DEEP ROOT BARRIER IS REQUIRED FOR ALL TREES PLANTED IN THE PLANTER STRIP. THE ROOT BARRIER MUST BE AT LEAST 20 FEET LONG, CENTERED ON THE TREE TRUNK AND BE INSTALLED ADJACENT TO THE SIDEWALK AND BACK OF CURB.
7. MAXIMUM TREE CANOPY (AT MATURITY) CAN BE 10-12 FEET MAXIMUM WIDTH.
8. TREE LIMB HEIGHT MUST BE AT LEAST 20 FEET HIGH ABOVE THE STREET ASPHALT.
9. NO TREES CAN BE PLANTED CLOSER THAN 5 FEET FROM WATER AND SEWER LATERALS.
10. NO TREE SHALL BE PLANTED CLOSER THAN 30 FEET OF ANY STREET CORNER, MEASURED FROM THE POINT OF NEAREST INTERSECTING CURBS or CURB LINES.
11. NO TREE SHALL BE PLANTED CLOSER THAN 10 FEET OF ANY FIREPLUG.
12. NO TREES OTHER THAN THOSE SPECIES LISTED AS SMALL TREES IN THE ENOCH CITY VEGETATION ORDINANCE MAY BE PLANTED UNDER or WITHIN 15 LATERAL FEET OF ANY OVERHEAD UTILITY WIRE.



ENOCH CITY
900 E MIDVALLEY RD
Enoch, UT 84721
Tel. (435) 586-1119

PLANTER STRIP
ROAD SECTIONS

SCALE:
N.T.S.
DATE:
DEC. 2022

DETAIL No.:

R3.4

SHEET:
1 of 1

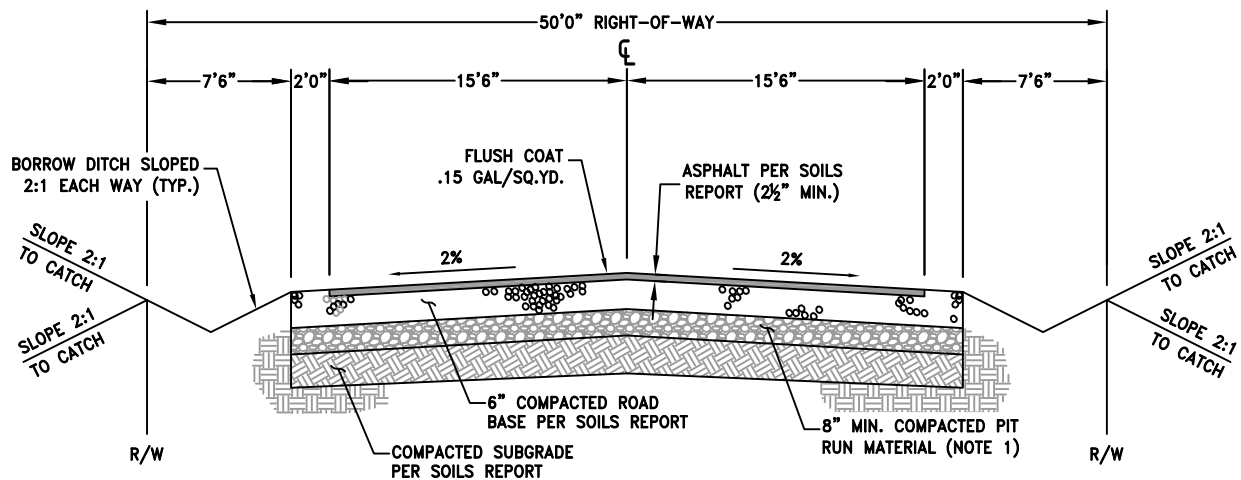

TYPICAL ROAD SECTION – UNIMPROVED ROAD w/ BORROW DITCH
N.T.S.

NOTES:

1. PIT RUN MATERIAL CAN BE ELIMINATED IF NATIVE MATERIAL MEETS OR EXCEEDS PIT RUN MATERIAL STANDARD GRADATION.



ENOCH CITY
900 E MIDVALLEY RD
Enoch, UT 84721
Tel. (435) 586-1119

RESIDENTIAL ESTATE
ROAD SECTION

SCALE:
N.T.S.
DATE:
DEC. 2022

DETAIL No.:

R3.5

SHEET:
1 of 1

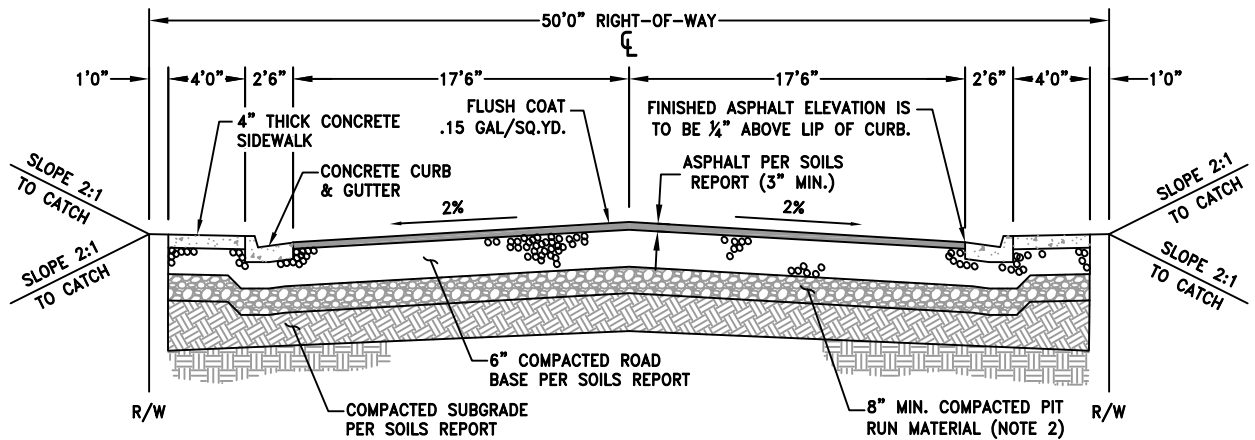

TYPICAL INDUSTRIAL ROAD SECTION - 50'0" RIGHT-OF-WAY
N.T.S.

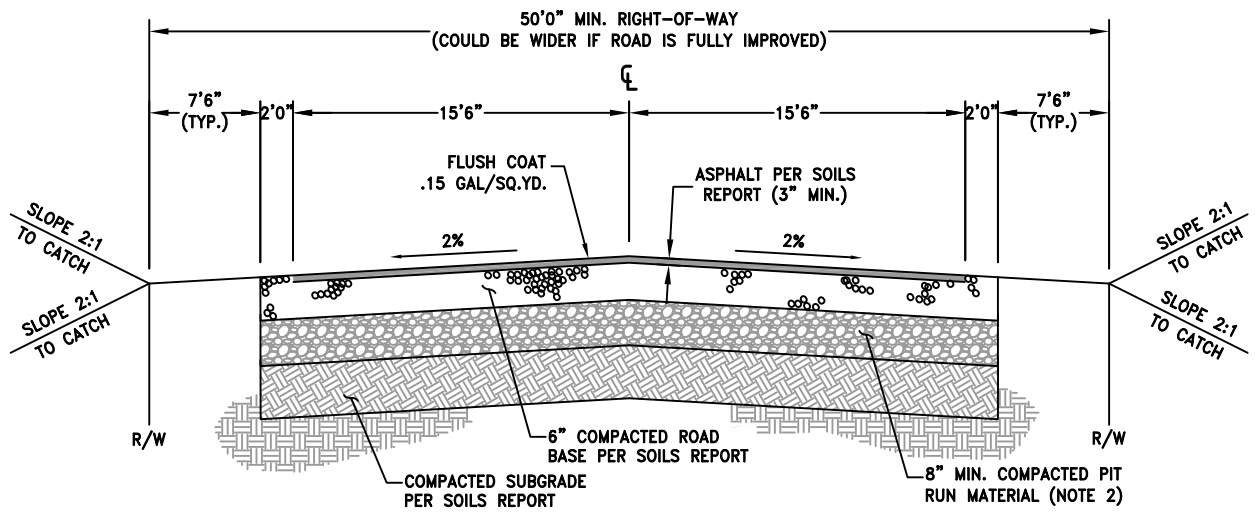

TYPICAL INDUSTRIAL ROAD SECTION - UNIMPROVED ROAD
N.T.S.

NOTES:

1. BACK OF SIDEWALK TO BE BACKFILLED TO TOP OF CONCRETE.
2. PIT RUN MATERIAL CAN BE ELIMINATED IF NATIVE MATERIAL MEETS OR EXCEEDS PIT RUN MATERIAL STANDARD GRADATION.



ENOCH CITY
900 E MIDVALLEY RD
Enoch, UT 84721
Tel. (435) 586-1119

TYPICAL 50'0"
INDUSTRIAL ROAD
SECTION

SCALE:
N.T.S.
DATE:
DEC. 2022

DETAIL No.:

R3.6

SHEET:
1 of 1

NOTES:

1. ROAD SECTIONS FOR PERMANENT CUL-DE-SACS SHALL BE THE SAME ROAD SECTION AS RECOMMENDED BY THE GEOTECHNICAL ENGINEER.
2. TEMPORARY CUL-DE-SAC ROAD SECTIONS SHALL BE 6" COMPACTED ROAD BASE ON 12" SCARIFIED AND RECOMPACTED SUBGRADE.
3. TEMPORARY CUL-DE-SACS SHALL BE INSTALLED ON ANY TEMPORARY DEAD END STREET LONGER THAN 140 FEET.

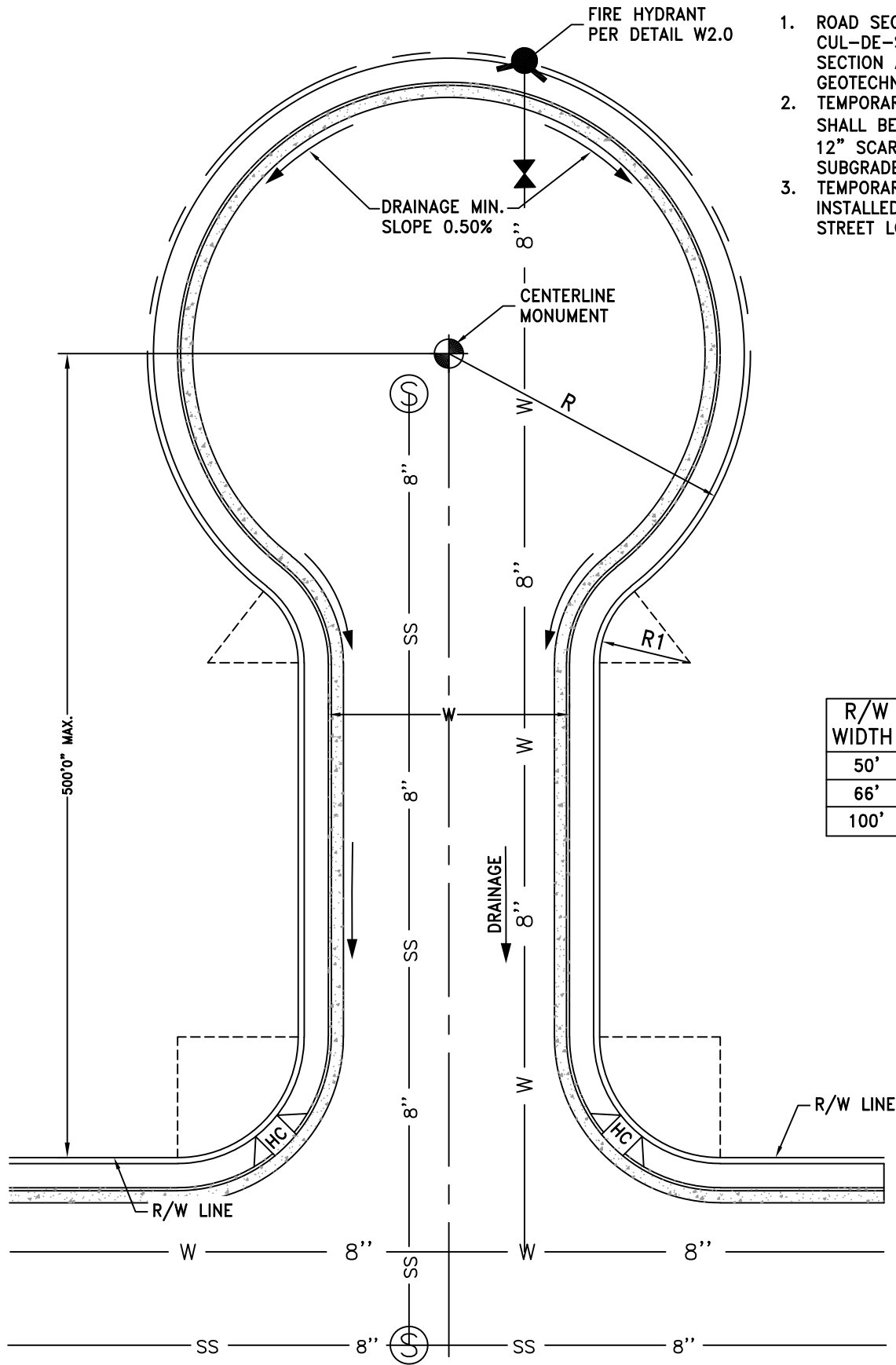

ENOCH CITY
 900 E MIDVALLEY RD
 Enoch, UT 84721
 Tel. (435) 586-1119

TYPICAL
 CUL-DE-SAC

SCALE:
 N.T.S.
 DATE:
 DEC. 2022

DETAIL No.:
 R4.0
 SHEET:
 1 of 1

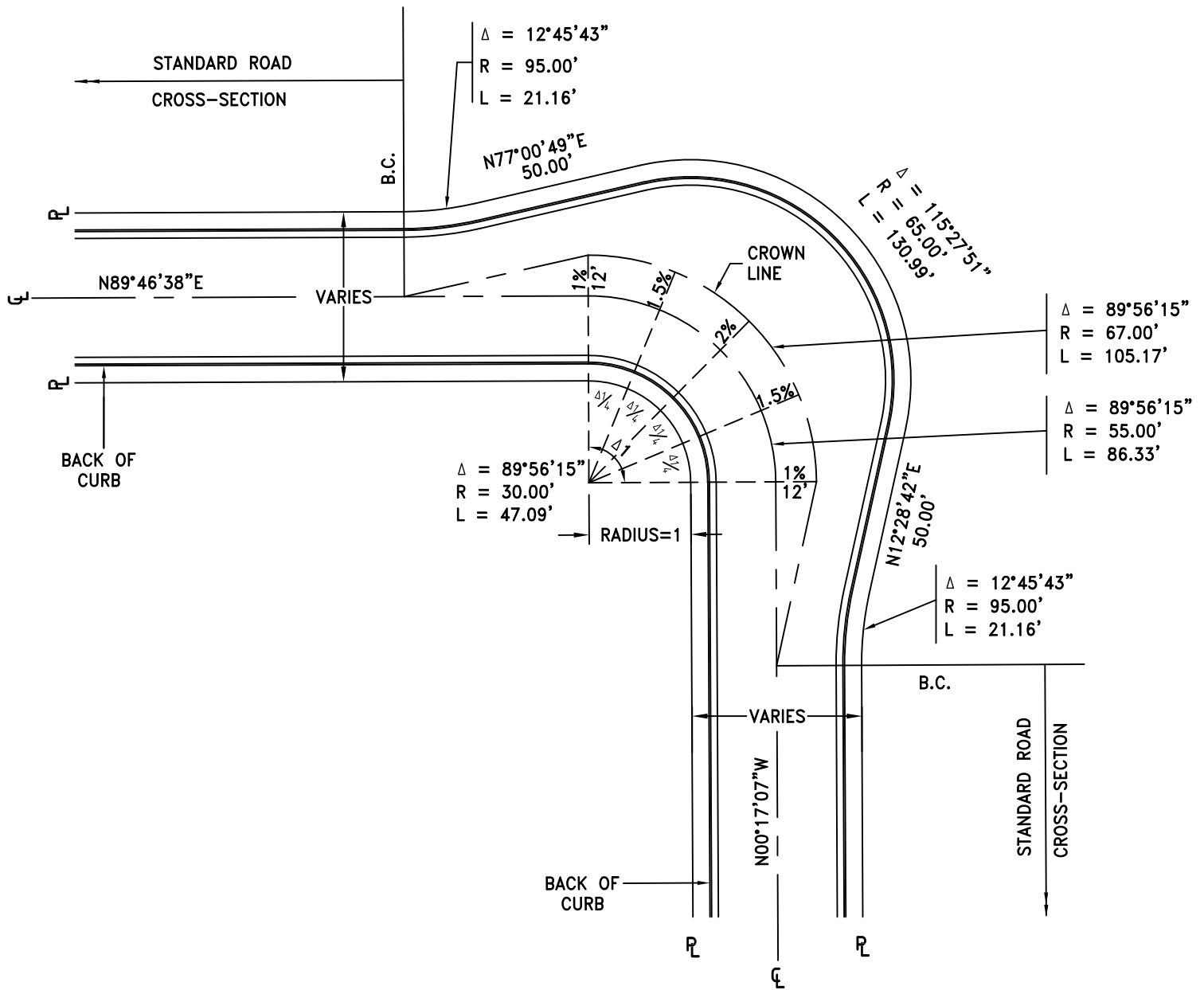

NOTES:

1. USE NORMAL SECTION FROM INNER CURB TO CENTER LINE.
2. FROM CROWN LINE TO OUTER CURB, THE STANDARD SLOPE IS 2%.
3. SUPER ELEVATION PERCENTAGES SHOWN ARE A STRAIGHT GRADE FROM CENTER LINE TO CROWN.
4. ELEVATIONS ARE REQUIRED AT EACH B.C.
5. KNUCKLES ARE ALLOWED ON 50'0" STREETS ONLY.
6. $\Delta 1 > 75^\circ$ USE RADIUS 1=30' MIN.
 65° TO 75° USE RADIUS 1=35' MIN.
 55° TO 65° USE RADIUS 1=45' MIN.



ENOCH CITY
 900 E MIDVALLEY RD
 Enoch, UT 84721
 Tel. (435) 586-1119

TYPICAL KNUCKLE FOR 50'0" WIDE STREET

SCALE:
 N.T.S.
 DATE:
 DEC. 2022

DETAIL No.:

R5.0

SHEET:
 1 of 1

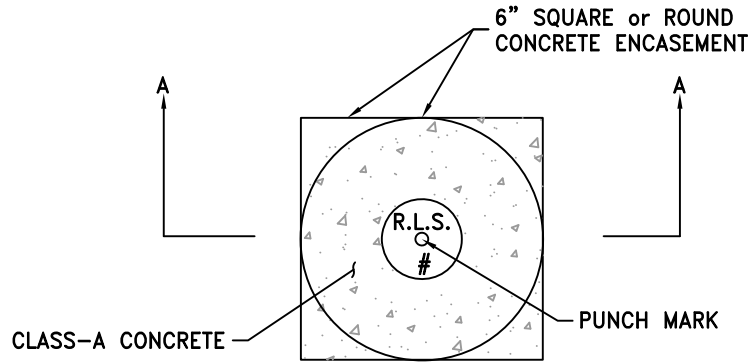

PLAN VIEW
N.T.S.

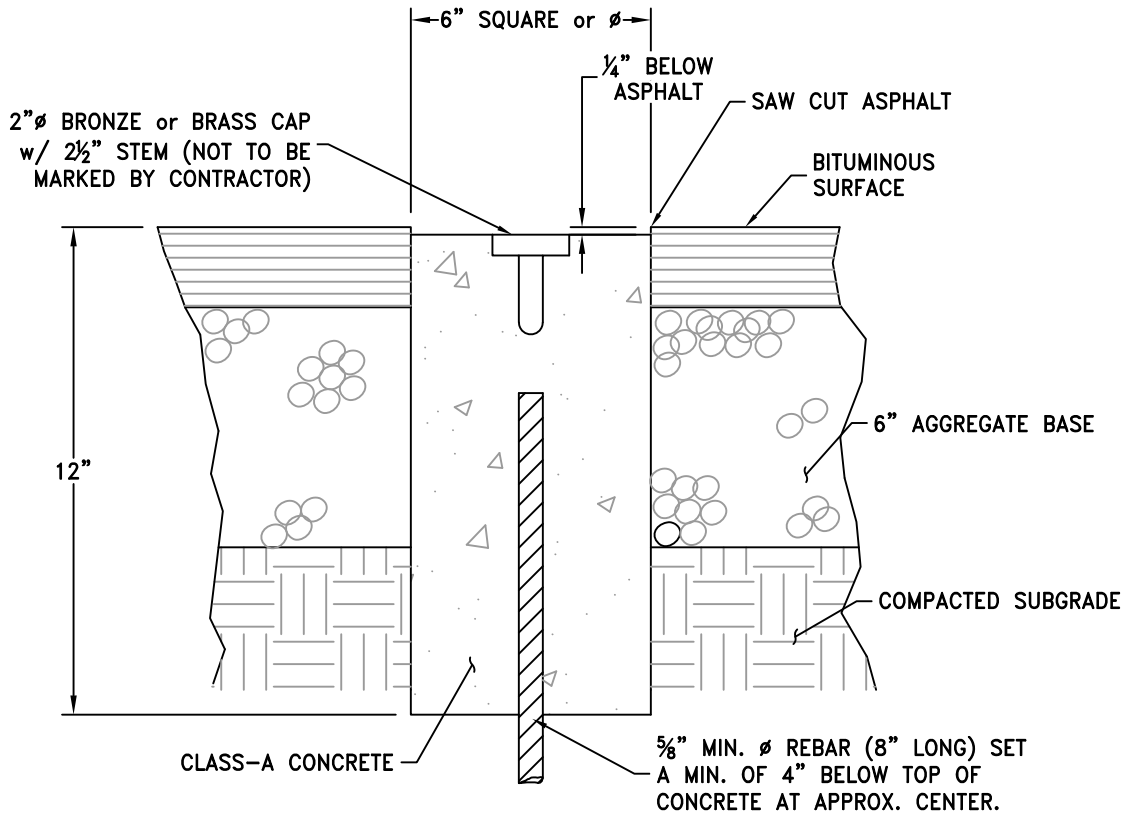

SECTION A-A
N.T.S.

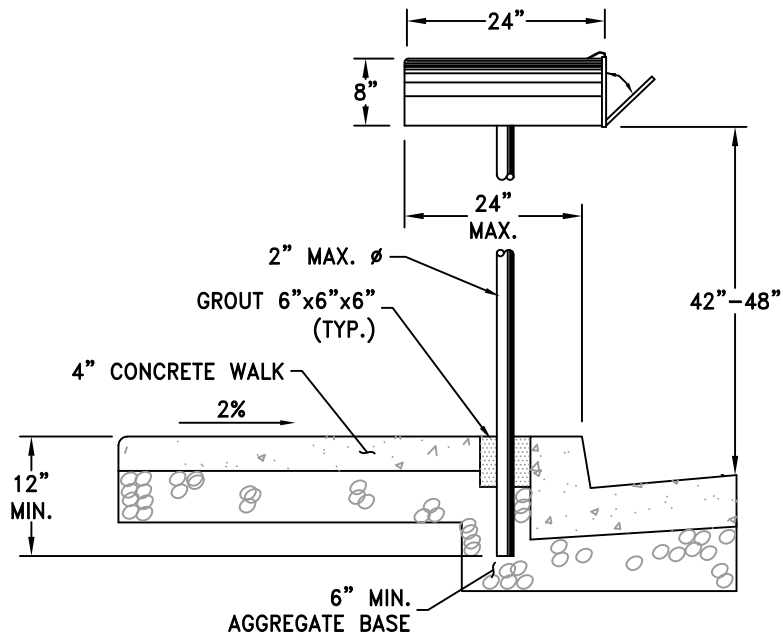

TYPICAL SECTION (GROUTED)
N.T.S.

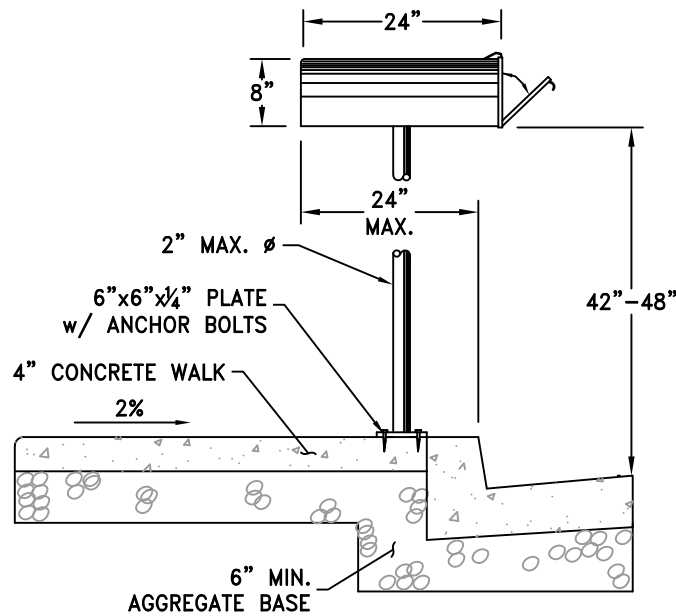

TYPICAL SECTION (ANCHOR BOLTS)
N.T.S.

NOTES:

1. SIGN POST SHALL BE SQUARE, GALVANIZED AND PERFORATED ON ALL FOUR SIDES.
2. ATTACH POST TO SLEEVE BY USING AT LEAST TWO $\frac{3}{8}$ " \varnothing DRIVE RIVETS or BOLTS.
3. PROVIDE 6" MINIMUM LAP BETWEEN POST AND THE SLEEVE.
4. UNLESS APPROVED, ALL SIGNS SHALL BE PLACED BEHIND THE SIDEWALK, MIDWAY BETWEEN THE P.C. & P.T. OF THE CURVE OF THE SIDEWALK.
5. UNLESS OTHERWISE INDICATED HEREON SIGN FACE SIZES SHALL NOT BE LESS THAN THE SIGN SIZES FOR CONVENTIONAL ROADS AS RECOMMENDED IN THE LATEST APPROVED VERSION OF THE MANUAL ON UNIFORM TRAFFIC CONTROL DEVICES. (MUTCD)

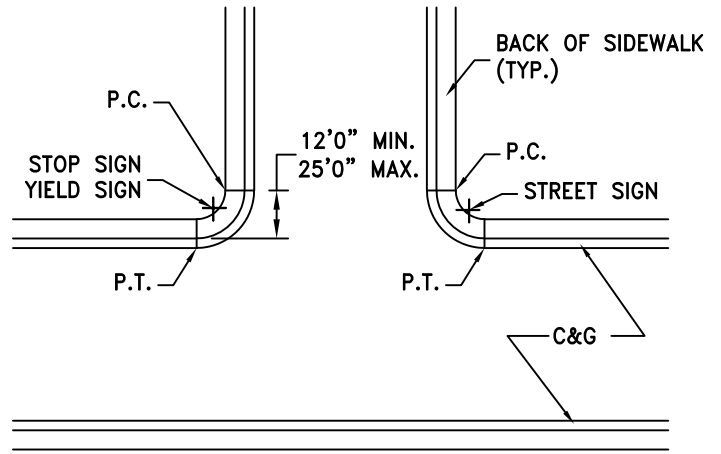

STOP & STREET SIGN LOCATION DETAIL
N.T.S.

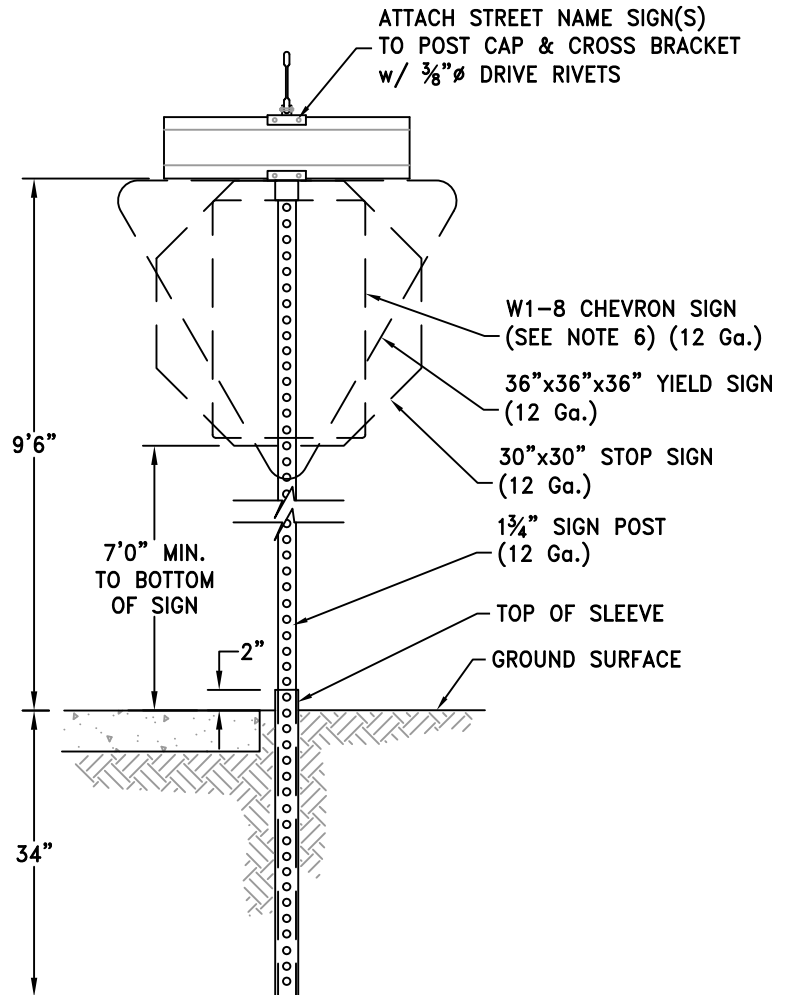
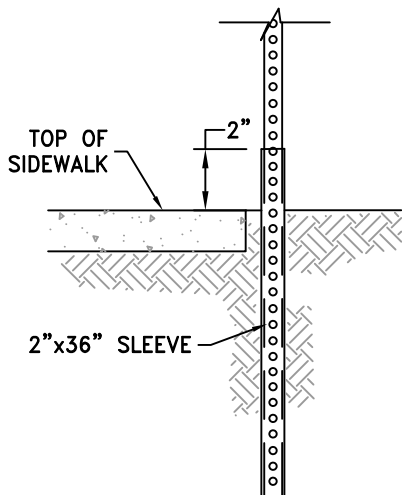
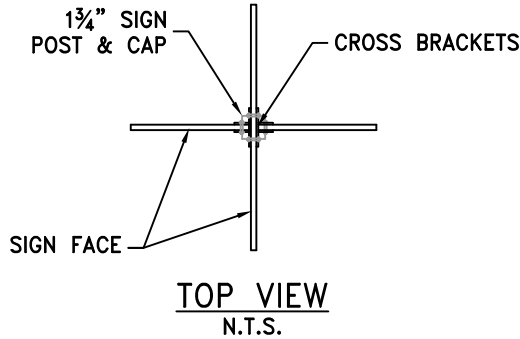

ENOCH CITY
900 E MIDVALLEY RD
Enoch, UT 84721
Tel. (435) 586-1119

STREET SIGN

SCALE:
N.T.S.
DATE:
DEC. 2022

DETAIL No.:

R8.0A

SHEET:
1 of 2



SINGLE LINE SIGN 6"
N.T.S.

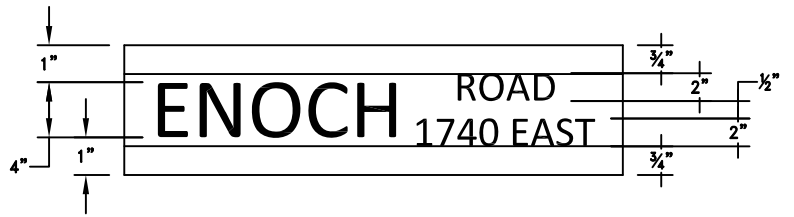

DOUBLE LINE SIGN 6"
N.T.S.



SIGN CROSS-SECTION
N.T.S.

NOTES:

1. SIGNS SHALL BE "EXTRUDED BLADE".
2. SIGN FACE SHALL BE WHITE LETTERS ON GREEN BACKGROUND 100% HIGH INTENSITY OR DIAMOND GRADE REFLECTIVE SHEETING BOTH LETTERS AND BACKGROUND.
3. ALL LETTERS SHALL BE UPPER CASE. ALL LETTERS AND NUMBERS SHALL CONFORM TO THE HEIGHT, WIDTH AND STROKE WIDTH, AND SPACING, AS PER U.S. DEPARTMENT OF TRANSPORTATION PUBLICATION "STANDARD ALPHABETS FOR HIGHWAY SIGNS".
4. SERIES LETTERS SHALL CONFORM TO THE FOLLOWING REQUIREMENTS AS DETERMINED BY CLASS OF SIGN CALLED FOR.
5. DOUBLE LINED SIGNS ARE USED FOR STREETS HAVING BOTH NUMBERS AND NAMES. THE STREET NUMBER SHALL BE THE PRIMARY COPY.
6. 6061 - T6 HEAT TREATED HIGH TENSILE DECREASED AND ALODINE 1200 FINISH. THICKNESS TO BE 0.08 FOR 6" BLADE.

SIGN CLASS	SIGN LENGTH	PRIMARY COPY	SUFFIX COPY
SINGLE LINE 6"	24"	4" C, D SERIES	
	30"	4" C, D SERIES	
	36"	4" A, B, C, D SERIES	
DOUBLE LINE 6"	24"	4" C, D SERIES	2" C SERIES
	30"	4" C, D SERIES	2" C SERIES
	36"	4" A, B, C, D SERIES	2" C SERIES



ENOCH CITY
900 E MIDVALLEY RD
Enoch, UT 84721
Tel. (435) 586-1119

STREET SIGN

SCALE:
N.T.S.
DATE:
DEC. 2022

DETAIL No.:

R8.0B

SHEET:
2 of 2

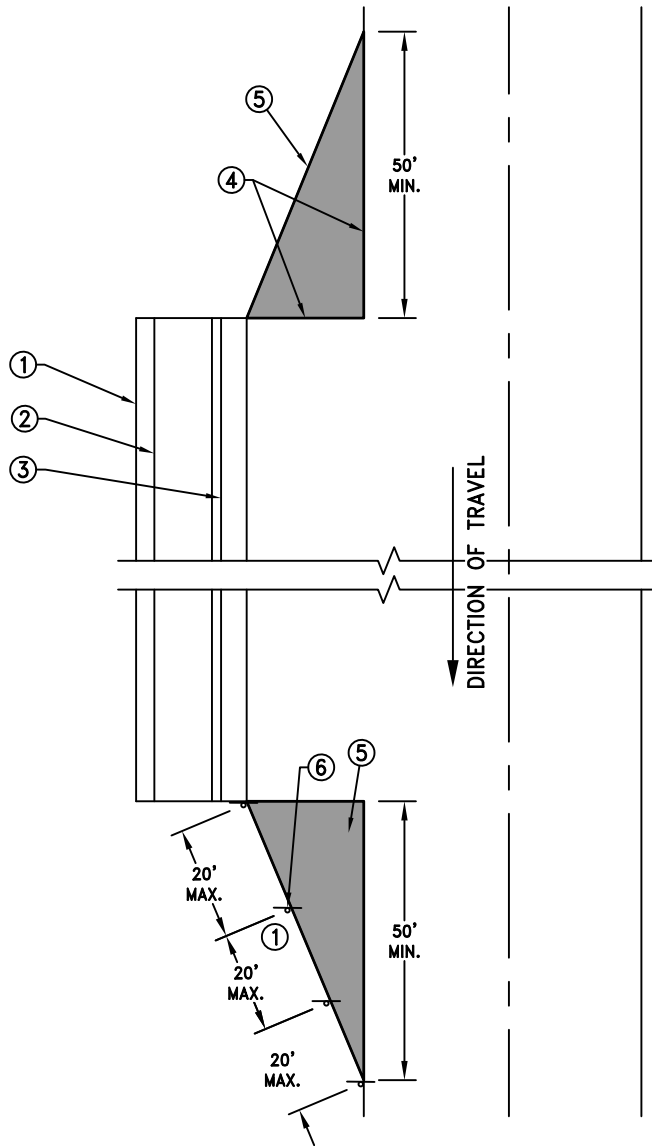

ASPHALT TAPER DETAIL
N.T.S.

CONSTRUCTION NOTES:

- ① RIGHT OF WAY LINE
- ② SIDEWALK
- ③ CURB AND GUTTER
- ④ SAW CUT REQUIRED
- ⑤ ASPHALT TAPER PER SOILS REPORT
- ⑥ CHEVRON SIGNS PER INSTALLATION
DETAIL (ONE SIGN AT CURB AND
ASPHALT, THENCE EVERY 20'0" MAX.



ENOCH CITY
900 E MIDVALLEY RD
Enoch, UT 84721
Tel. (435) 586-1119

ASPHALT TAPERS

SCALE:
N.T.S.
DATE:
DEC. 2022

DETAIL No.:

R9.0

SHEET:
1 of 1

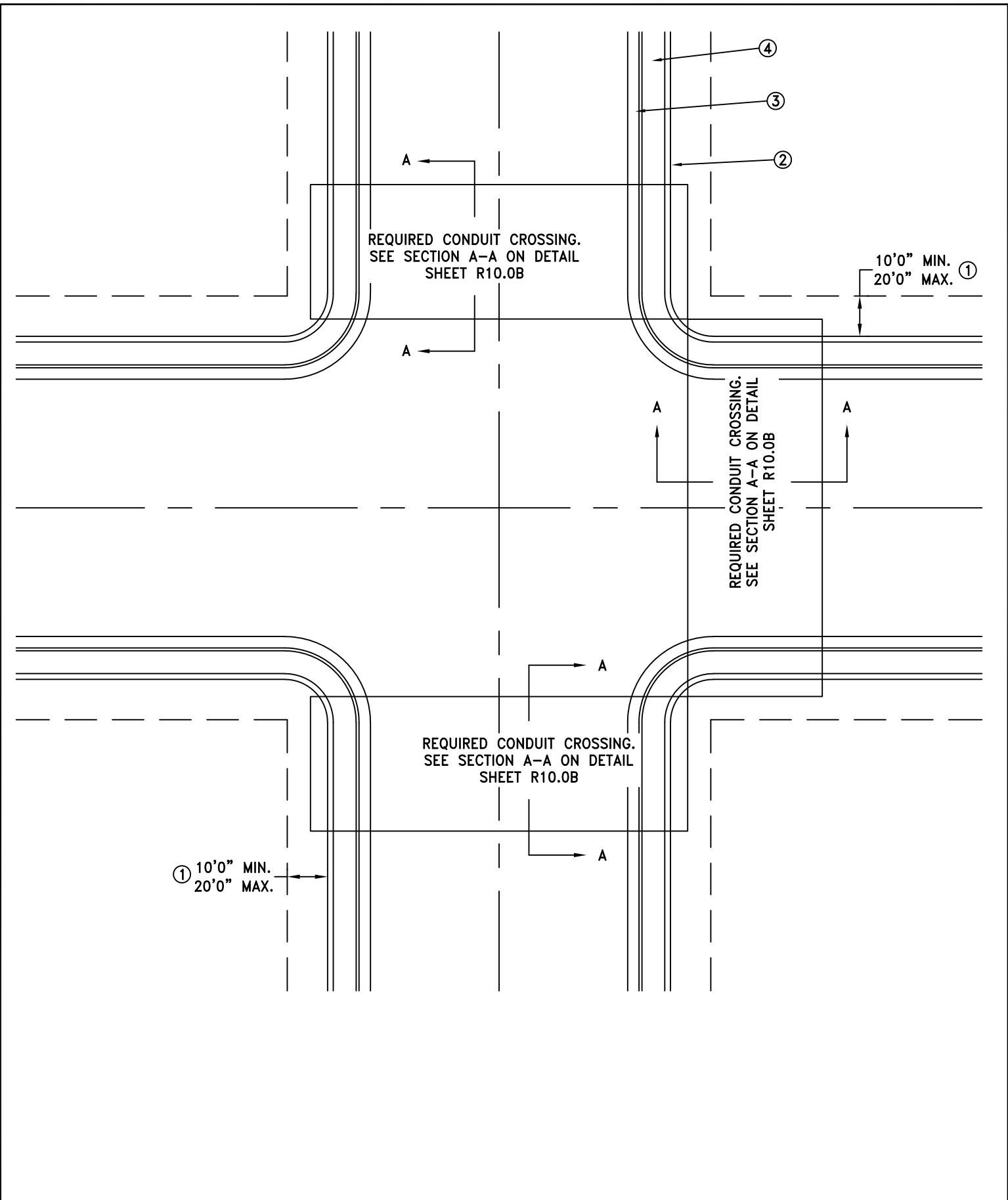

ENOCH CITY
 900 E MIDVALLEY RD
 Enoch, UT 84721
 Tel. (435) 586-1119

Copyright © 2023

TYPICAL CONDUIT CROSSING

SCALE:
 N.T.S.
 DATE:
 DEC. 2022

DETAIL No.:

R10.0A

SHEET:
 1 of 2

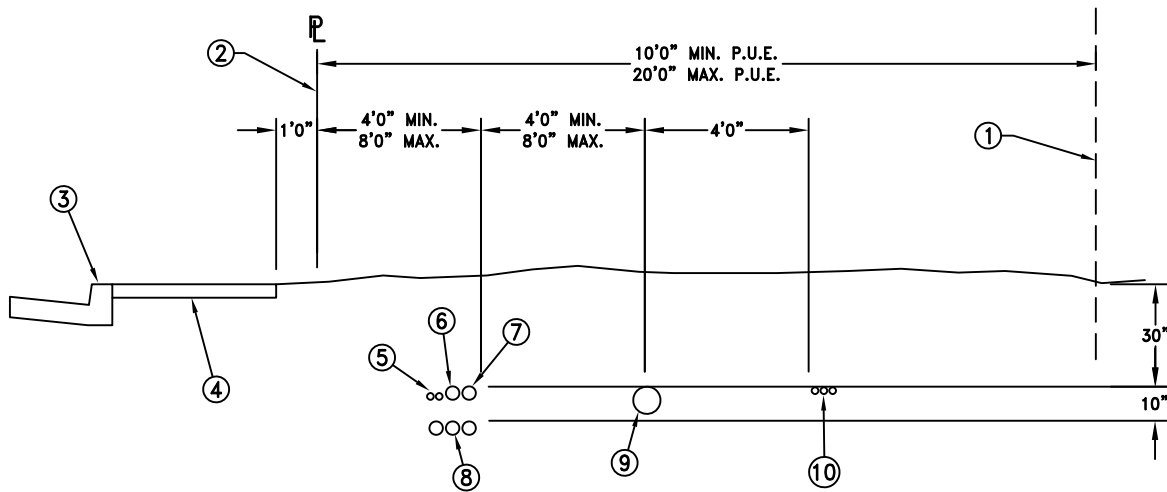

SECTION 'A-A' - TYPICAL CONDUIT CROSSING LAYOUT
N.T.S.

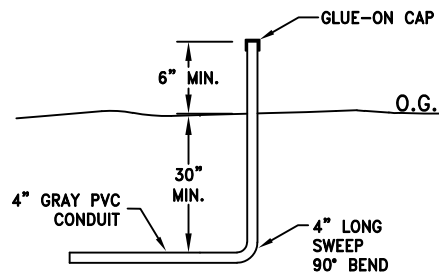

DETAIL 'A'- SPARE CONDUIT VERTICAL LOCATE RISER
N.T.S.

CONSTRUCTION NOTES:

- ① CHEVRON SIGNS PER INSTALLATION DETAIL (ONE SIGN AT CURB AND ASPHALT, THENCE EVERY 20'0" MAX.
- ② PROPERTY LINE
- ③ CURB AND GUTTER
- ④ SIDEWALK
- ⑤ (2) 2" GRAY PVC CABLE T.V. CONDUITS (TYP.)
- ⑥ (1) 4" GRAY PVC TELEPHONE CONDUIT (TYP.)
- ⑦ (1) 4" GRAY PVC SPARE CONDUIT w/ LOCATION RISER (TYP.) SEE DETAIL 'A'
- ⑧ (3) 6" GRAY PVC ELECTRICAL CONDUITS (TYP.)
- ⑨ (1) 8" SCH40 - WHITE PVC GAS CONDUIT (TYP.)
- ⑩ (3) 2" GRAY PVC CONDUITS FOR SIGNALS (TYP.) (SEE NOTE 2)

NOTES:

- 1. EXTEND ALL CONDUITS 3'0" BEYOND PROPERTY LINE.
- 2. SIGNAL CONDUITS INSTALLED ONLY AT INTERSECTIONS OF ARTERIALS WITH MAJOR COLLECTORS AND INTERSECTIONS OF TWO ARTERIALS.
- 3. CONDUITS CAN BE ELIMINATED WITH WRITTEN APPROVAL OF UTILITIES.
- 4. ALL CONDUIT TRENCHES TO BE COMPACTED TO 95% OF MAXIMUM FOR FULL DEPTH.
- 5. CONDUITS LOCATED ON ALL INTERSECTION LEGS BUT ONE.



ENOCH CITY
900 E MIDVALLEY RD
Enoch, UT 84721
Tel. (435) 586-1119

TYPICAL CONDUIT CROSSING

SCALE:
N.T.S.
DATE:
DEC. 2022

DETAIL No.:

R10.0B

SHEET:
2 of 2

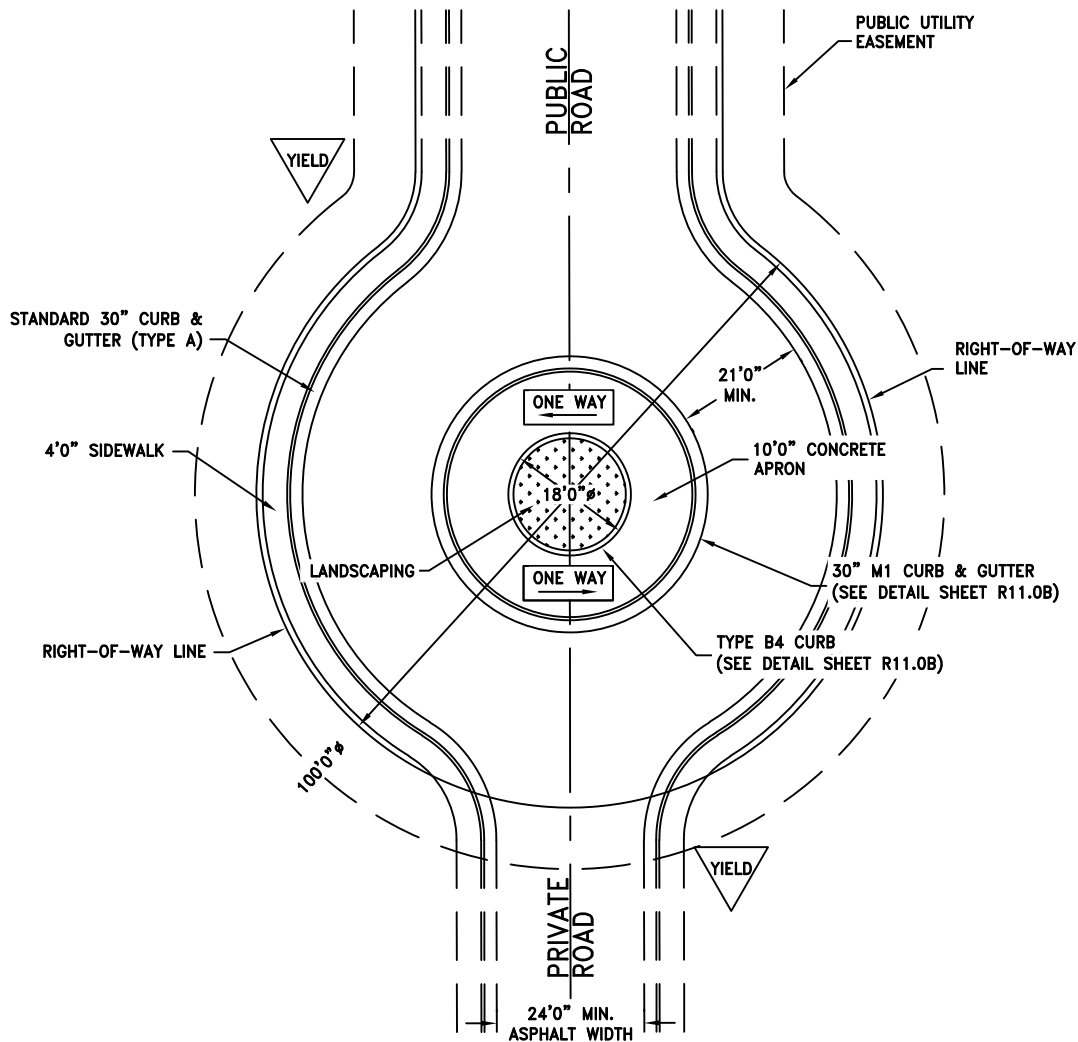

P.U.D. ACCESS TURN-AROUND PLAN VIEW
N.T.S.

NOTES:

1. INTERIOR ISLAND, INCLUDING M1 & B4 CURB, TRUCK APRON AND LANDSCAPE AREA IS OPTIONAL.
2. PROPER SIGNAGE IS NEEDED FOR A ROUNDABOUT SITUATION.



ENOCH CITY
900 E MIDVALLEY RD
Enoch, UT 84721
Tel. (435) 586-1119

**P.U.D. ACCESS
TURN-AROUND**

SCALE:
N.T.S.
DATE:
DEC. 2022

DETAIL No.:

R11.0A

SHEET:
1 of 2

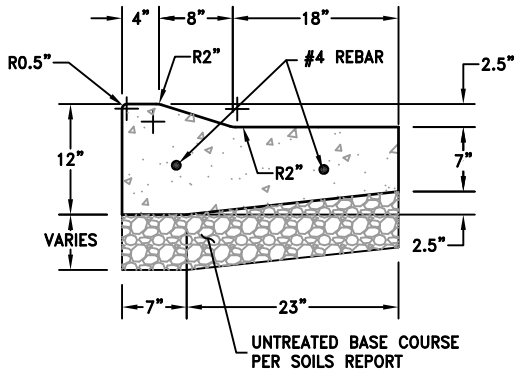

TYPE M1 CURB & GUTTER
N.T.S.

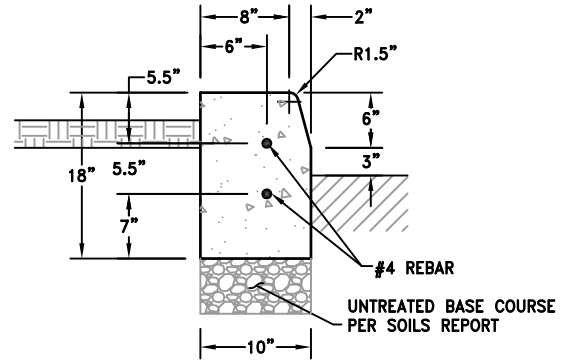

TYPE B4 CURB
N.T.S.

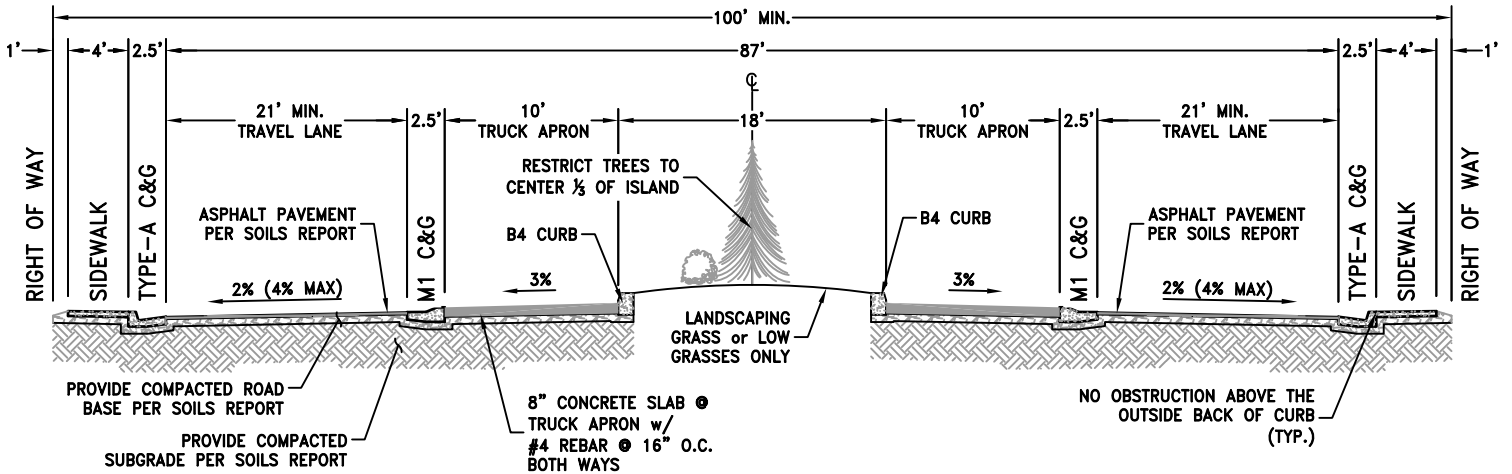

P.U.D. ACCESS TURN-AROUND CROSS SECTION
N.T.S.



ENOCH CITY
900 E MIDVALLEY RD
Enoch, UT 84721
Tel. (435) 586-1119

**P.U.D. ACCESS
TURN-AROUND**

SCALE:
N.T.S.
DATE:
DEC. 2022

DETAIL No.:

R11.0B

SHEET:
2 of 2

CONSTRUCTION NOTES:

- ① 'DARK SKY' COMPLIANT LIGHT FIXTURE PER ENOCH CITY ENGINEERING DESIGN STANDARDS, SECTION 4.5.1.I AND TABLE 4.12
- ② POLE PER ENOCH CITY ENGINEERING DESIGN STANDARDS, SECTION 4.5.1.II AND TABLE 4.13
- ③ HAND-HOLE PER ENOCH CITY ENGINEERING DESIGN STANDARDS, SECTION 4.5.1.II
- ④ TOP OF POLE BARREL TO BE SAME ELEVATION AS TOP OF SIDEWALK.
- ⑤ 1/4" DIA. WIRE HOLE WITH RUBBER GROMMET.
- ⑥ 1" PVC CONDUIT (BY DEVELOPER).
- STREETLIGHT JUNCTION BOX TO BE PLACED AT EACH STREET LIGHT,
- ⑦ NORDIC FIBERGLASS INC. DWG. NO. PHH2-161912-MG, or CARSON 1324-12-15-4PL/GRN/ELEC. O.A.E. (BY DEVELOPER)
- ⑧ TRANSFORMER or SECONDARY JUNCTION BOX (BY POWER COMPANY).
5 AMP IN-LINE FUSE WILL BE INSTALLED BY THE CONTRACTOR ON THE 120 VOLT LINE CONNECTING TO THE POWER COMPANY'S
- ⑨ SECONDARY POWER IN THE BOX. FUSE HOLDER TO BE A GOULD FEBIII w/ A FSBI, O.A.E.
- ⑩ 1" or 3/4" ROAD BASE (O.A.E.) COMPACTED TO 95% OF MAXIMUM DENSITY.
- ⑪ CURB, GUTTER & SIDEWALK (BY OTHERS)
- ⑫ ALL WIRING & WIRE SIZES PER NEC.
- POWER SUPPLY JUNCTION BOX, NORDIC FIBERGLASS INC. DWG. NO. PHH2-161912-MG, O.A.E. (BY DEVELOPER) NOTE: THIS BOX CAN BE ELIMINATED IF THE STREET LIGHT BOX IS WITHIN 10 FEET OF THE POWER COMPANY POWER SOURCE.
- ⑬ CONCRETE BASE MOUNTED POLE PER DETAIL SHEET R12.2 CAN BE SUBSTITUTED FOR A DIRECT BURIAL POLE.
- ⑭ DIRECT BURIAL CABLE (BY DEVELOPER).
- ⑮ ALL ELECTRICAL CABLE SPLICE CONNECTOR SHALL BE WATERPROOF 3M DIRECT BURY SPLICE KITS O.A.E.

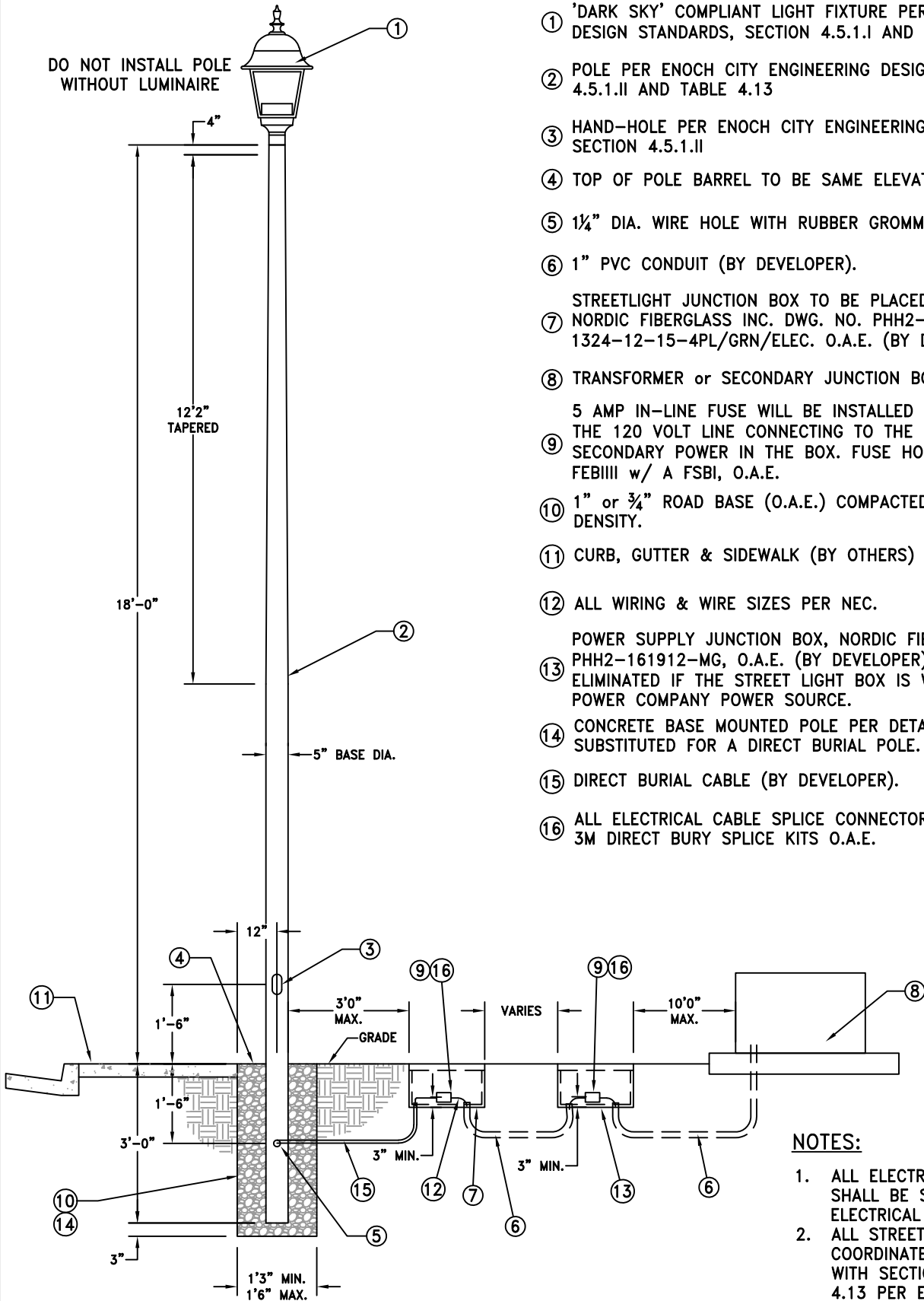

NOTES:

- 1. ALL ELECTRIC CABLES AND CONDUITS SHALL BE SIZED PER THE NATIONAL ELECTRICAL CODE.
- 2. ALL STREET LIGHT LOCATIONS TO BE COORDINATED WITH POWER COMPANY WITH SECTION 4.5.2.IV AND TABLE 4.13 PER ENOCH CITY ENGINEERING DESIGN STANDARDS.



ENOCH CITY
900 E MIDVALLEY RD
Enoch, UT 84721
Tel. (435) 586-1119

LOCAL STREET LIGHT

SCALE:
N.T.S.
DATE:
DEC. 2022

DETAIL No.:

R12.1

SHEET:
1 of 1

DO NOT INSTALL POLE WITHOUT LUMINAIRE

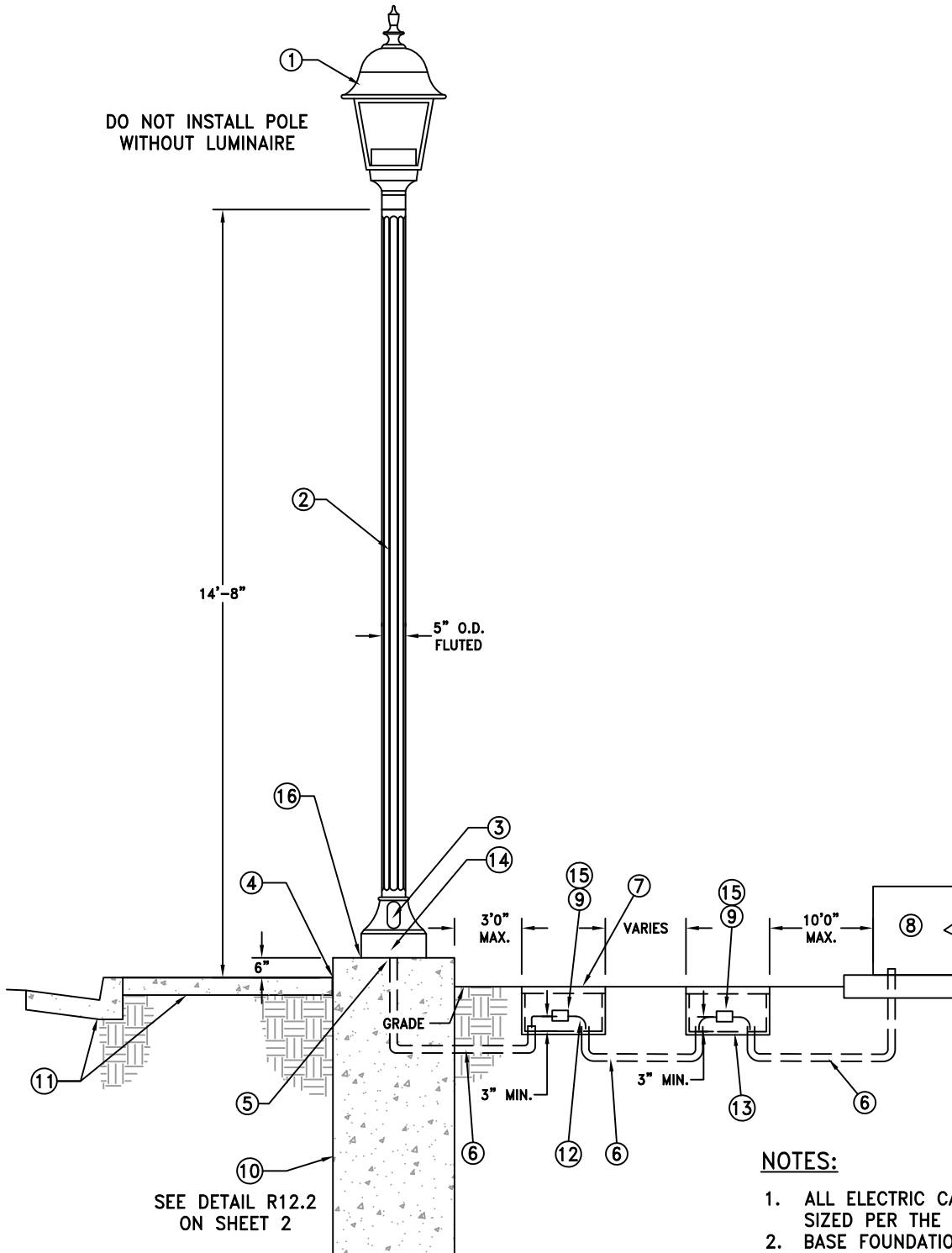

SEE DETAIL R12.2 ON SHEET 2

NOTES:

1. ALL ELECTRIC CABLES AND CONDUITS SHALL BE SIZED PER THE NATIONAL ELECTRICAL CODE.
2. BASE FOUNDATIONS IN SIDEWALK SHALL HAVE A 1/2" EXPANSION JOINT AROUND THE BASE.
3. ALL STREET LIGHT LOCATIONS TO BE COORDINATED WITH POWER COMPANY WITH SECTION 4.5.2.IV AND TABLE 4.13 PER ENOCH CITY ENGINEERING DESIGN STANDARDS.



ENOCH CITY
900 E MIDVALLEY RD
Enoch, UT 84721
Tel. (435) 586-1119

COMMERCIAL STREET LIGHT

SCALE:
N.T.S.
DATE:
DEC. 2022

DETAIL No.:

R12.2A

SHEET:
1 of 2

CONSTRUCTION NOTES:

- ① 'DARK SKY' COMPLIANT LIGHT FIXTURE PER ENOCH CITY ENGINEERING DESIGN STANDARDS, SECTION 4.5.1.I AND TABLE 4.12
- ② POLE PER ENOCH CITY ENGINEERING DESIGN STANDARDS, SECTION 4.5.1.II AND TABLE 4.13
- ③ HAND-HOLE PER ENOCH CITY ENGINEERING DESIGN STANDARDS, SECTION 4.5.1.II
- ④ POLE BASE AT BACK OF SIDEWALK WITH TOP OF BASE CONCRETE TO BE 6" HIGHER THAN TOP OF SIDEWALK. ½"x6" FELT BETWEEN LIGHT BASE AND SIDEWALK.
- ⑤ POWER FEED ROUTED THROUGH POLE BASE IN 1"Ø PVC CONDUIT.
- ⑥ 1" PVC CONDUIT (BY DEVELOPER).
- ⑦ STREETLIGHT JUNCTION BOX TO BE PLACED AT EACH STREET LIGHT, NORDIC FIBERGLASS INC. DWG. NO. PHH2-161912-MG, OR CARSON 1324-12-15-4PL/GRN/ELEC. O.A.E. (BY DEVELOPER).
- ⑧ TRANSFORMER or SECONDARY JUNCTION BOX (BY POWER COMPANY).
A 5 AMP IN-LINE FUSE WILL BE INSTALLED BY THE CONTRACTOR ON THE 120 VOLT LINE CONNECTING TO THE POWER COMPANY'S SECONDARY POWER IN THE BOX. FUSE HOLDER TO BE A GOULD FEBIII w/ A FSBI, O.A.E.
- ⑩ CONCRETE BASE FOUNDATION, TYPE A CONCRETE, REINFORCEMENT AS SHOWN.
- ⑪ CURB, GUTTER & SIDEWALK (BY OTHERS)
- ⑫ ALL WIRING & WIRE SIZES PER NEC.
- ⑬ POWER SUPPLY JUNCTION BOX, NORDIC FIBERGLASS INC. DWG. NO. PHH2-161912-MG, O.A.E. (BY DEVELOPER) NOTE: THIS BOX CAN BE ELIMINATED IF THE STREET LIGHT BOX IS WITHIN 10 FEET OF THE POWER COMPANY POWER SOURCE.
- ⑭ ANCHOR BOLTS MATERIAL, SIZE & PATTERN PER POLE MANUFACTURES REQUIREMENTS.
- ⑮ ALL ELECTRICAL CABLE SPLICE CONNECTORS SHALL BE WATERPROOF 3M DIRECT BURY SPLICE KITS O.A.E.
- ⑯ NON-SHRINK GROUT BETWEEN POLE BASE AND FOUNDATION.

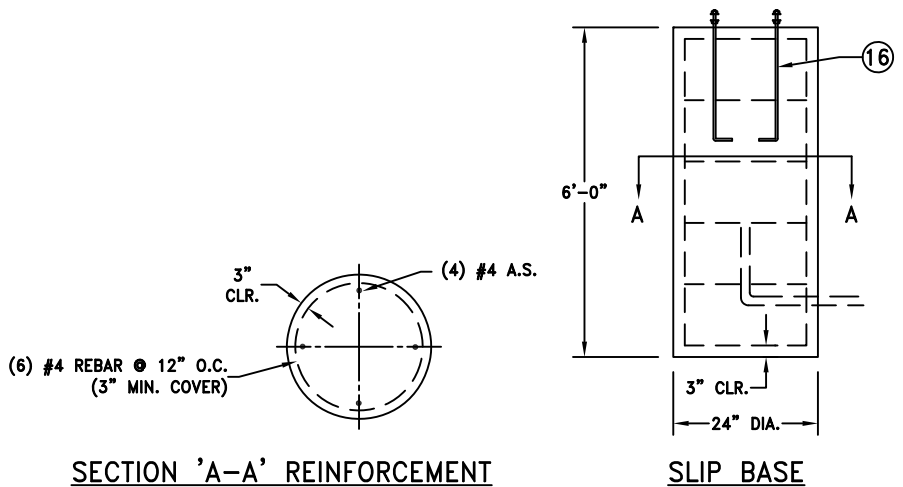

LIGHT POLE FOUNDATION DETAIL
N.T.S.



ENOCH CITY
900 E MIDVALLEY RD
Enoch, UT 84721
Tel. (435) 586-1119

COMMERCIAL STREET LIGHT

SCALE:
N.T.S.
DATE:
DEC. 2022

DETAIL No.:

R12.2B

SHEET:
2 of 2

NOTES:

1. ALL ELECTRIC CABLES AND CONDUITS SHALL BE SIZED PER THE NATIONAL ELECTRICAL CODE.
2. BASE FOUNDATIONS IN SIDEWALK SHALL HAVE A 1/2" EXPANSION JOINT AROUND THE BASE.
3. ALL STREET LIGHT LOCATIONS TO BE COORDINATED WITH POWER COMPANY WITH SECTION 4.5.2.IV AND TABLE 4.13 PER ENOCH CITY ENGINEERING DESIGN STANDARDS.

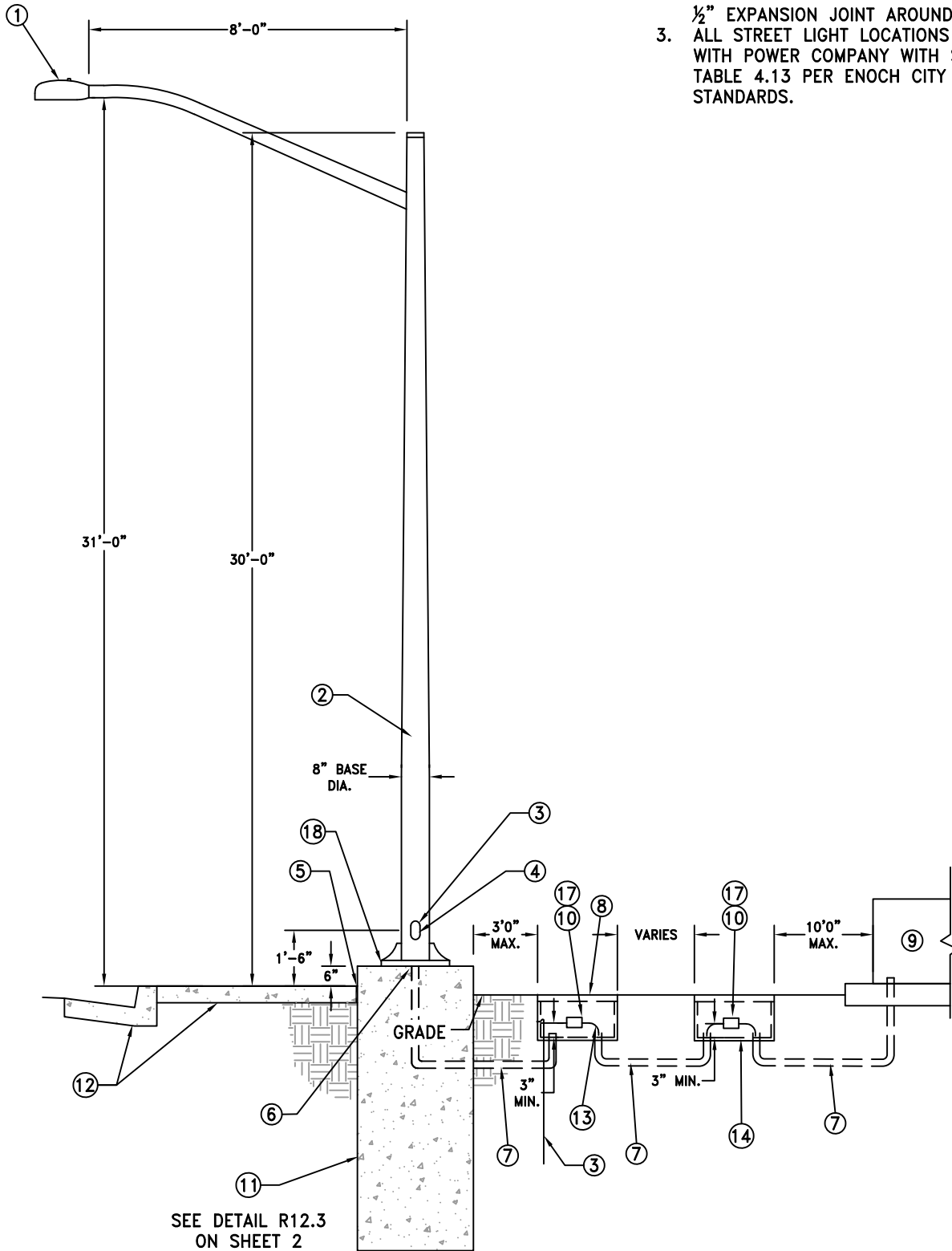

ENOCH CITY
 900 E MIDVALLEY RD
 Enoch, UT 84721
 Tel. (435) 586-1119

INDUSTRIAL STREET LIGHT

SCALE:
 N.T.S.
 DATE:
 DEC. 2022

DETAIL No.:

R12.3A

SHEET:
 1 of 2

CONSTRUCTION NOTES:

- ① 'DARK SKY' COMPLIANT LIGHT FIXTURE PER ENOCH CITY ENGINEERING DESIGN STANDARDS, SECTION 4.5.1.I AND TABLE 4.12
- ② POLE PER ENOCH CITY ENGINEERING DESIGN STANDARDS, SECTION 4.5.1.II AND TABLE 4.13
- ③ 5/8"x6'0" COPPER COATED STEEL GROUND ROD w/ NO.6 GROUND WIRE CONNECTED TO GROUND LUG AT HAND HOLE.
- ④ HAND-HOLE PER ENOCH CITY ENGINEERING DESIGN STANDARDS, SECTION 4.5.1.II
- ⑤ POLE BASE AT BACK OF SIDEWALK WITH TOP OF BASE CONCRETE TO BE 6" HIGHER THAN TOP OF SIDEWALK. 1/2"x6" FELT BETWEEN LIGHT BASE AND SIDEWALK.
- ⑥ POWER FEED ROUTED THROUGH POLE BASE IN 1"Ø PVC CONDUIT.
- ⑦ 1" PVC CONDUIT (BY DEVELOPER).
- ⑧ STREETLIGHT JUNCTION BOX TO BE PLACED AT EACH STREET LIGHT, NORDIC FIBERGLASS INC. DWG. NO. PHH2-161912-MG, OR CARSON 1324-12-15-4PL/GRN/ELEC. O.A.E. (BY DEVELOPER).
- ⑨ TRANSFORMER or SECONDARY JUNCTION BOX (BY POWER COMPANY).
- ⑩ A 5 AMP IN-LINE FUSE WILL BE INSTALLED BY THE CONTRACTOR ON THE 120 VOLT LINE CONNECTING TO THE POWER COMPANY'S SECONDARY POWER IN THE BOX. FUSE HOLDER TO BE A GOULD FEBIII w/ A FSBI, O.A.E.
- ⑪ CONCRETE BASE FOUNDATION, TYPE A CONCRETE, REINFORCEMENT AS SHOWN.
- ⑫ CURB, GUTTER & SIDEWALK (BY OTHERS)
- ⑬ ALL WIRING & WIRE SIZES PER NEC.
- ⑭ POWER SUPPLY JUNCTION BOX, NORDIC FIBERGLASS INC. DWG. NO. PHH2-161912-MG, O.A.E. (BY DEVELOPER) NOTE: THIS BOX CAN BE ELIMINATED IF THE STREET LIGHT BOX IS WITHIN 10 FEET OF THE POWER COMPANY POWER SOURCE.
- ⑮ SLIP BASE PER POLE MANUFACTURES DETAIL.
- ⑯ ANCHOR BOLTS MATERIAL, SIZE & PATTERN PER POLE MANUFACTURES REQUIREMENTS.
- ⑰ ALL ELECTRICAL CABLE SPLICE CONNECTORS SHALL BE WATERPROOF 3M DIRECT BURY SPLICE KITS O.A.E.
- ⑱ NON-SHRINK GROUT BETWEEN POLE BASE AND FOUNDATION.

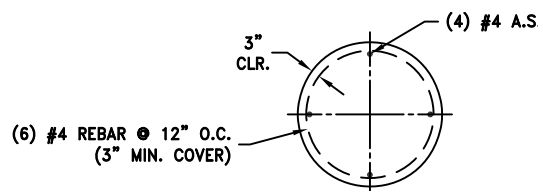

SECTION 'A-A' REINFORCEMENT

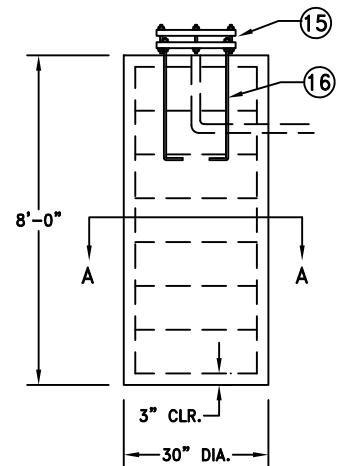

SLIP BASE

LIGHT POLE FOUNDATION DETAIL
N.T.S.



ENOCH CITY
900 E MIDVALLEY RD
Enoch, UT 84721
Tel. (435) 586-1119

INDUSTRIAL STREET LIGHT

SCALE:
N.T.S.
DATE:
DEC. 2022

DETAIL No.:

R12.3B

SHEET:
2 of 2

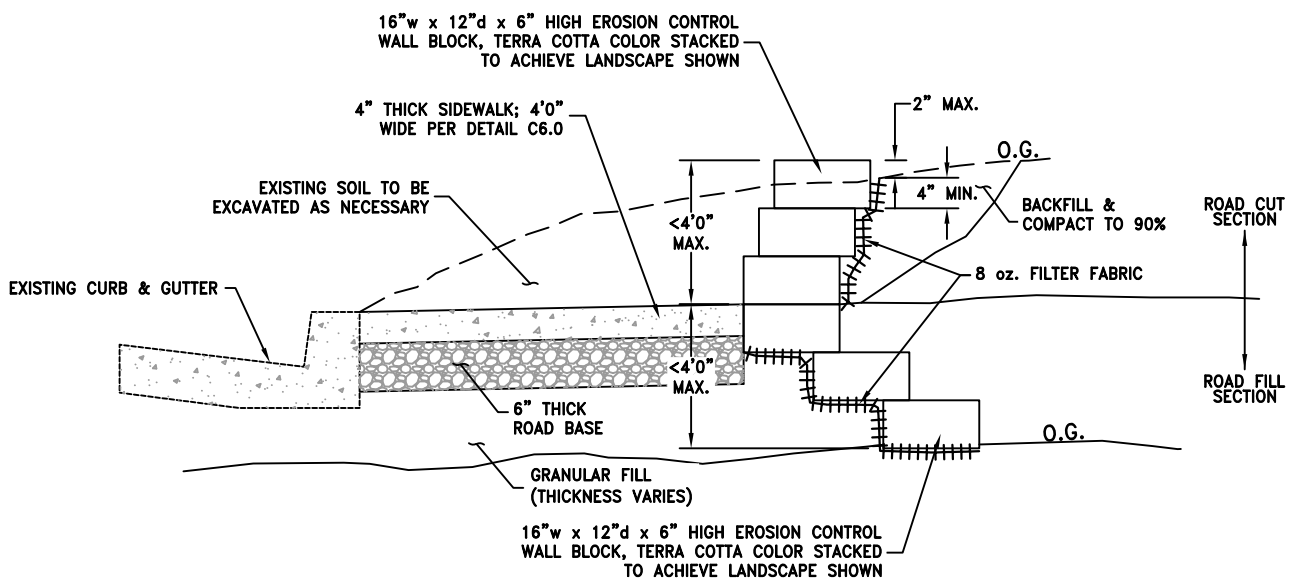

EROSION CONTROL WALL @ BACK OF SIDEWALK
N.T.S.

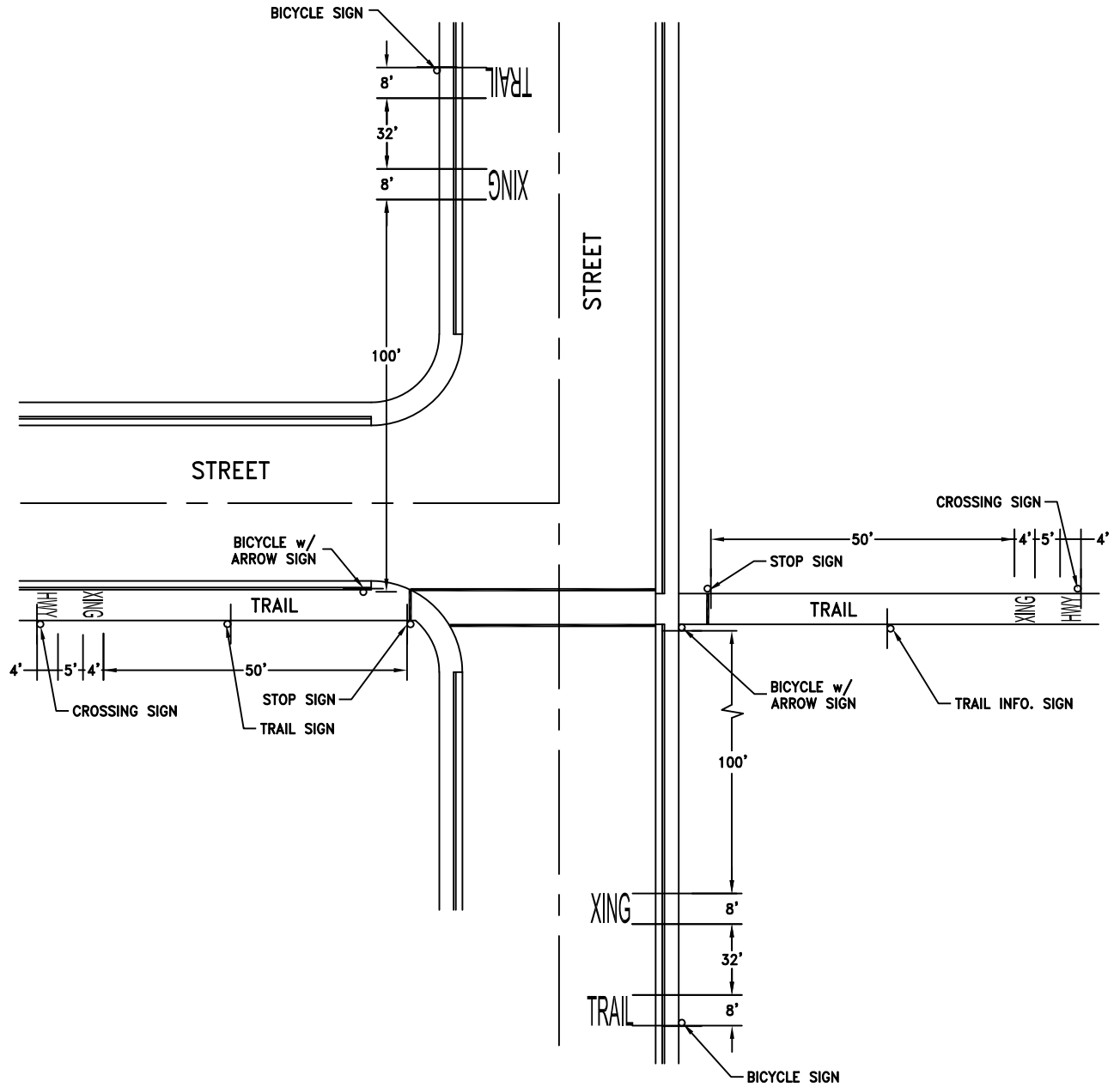

ENOCH CITY
 900 E MIDVALLEY RD
 Enoch, UT 84721
 Tel. (435) 586-1119

STREET/TRAIL CROSSING DETAIL

SCALE:
 N.T.S.
 DATE:
 DEC. 2022

DETAIL No.:

R14.1

SHEET:
 1 of 1



NOTES:

1. ALL SIGN FACE MATERIALS, COLORS, LETTERS, INSTALLATION, ETC. SHALL CONFORM TO CITY ENGINEERING STANDARD DRAWING R8.0B



ENOCH CITY
 900 E MIDVALLEY RD
 Enoch, UT 84721
 Tel. (435) 586-1119

TRAIL SIGN FACE DETAIL

SCALE:
 N.T.S.
 DATE:
 DEC. 2022

DETAIL No.:

R14.2

SHEET:
 1 of 1



PER DETAIL R8.0 (TYP.)



CURB & GUTTER

[30°
45°
60°
90°]

4" WIDE WHITE COLOR STRIPES (TYP.)

[34'
27'
24'
18']

9'0" (TYP.)

MINIMUM STREET WIDTH

TRAFFIC FLOW

MINIMUM STREET WIDTH (FACE OF CURB TO FACE OF CURB)

TWO-WAY STREETS: 67' WITH ANGLE PARKING ON BOTH SIDES OF STREET
58' WITH ANGLE PARKING ON ONE SIDE & PARALLEL PARKING ON OPPOSITE SIDE.

ONE-WAY STREETS: 45' WITH ANGLE PARKING ON ONE SIDE & PARALLEL PARKING ON OPPOSITE SIDE.
36' WITH ANGLE PARKING ON ONE SIDE & NO PARKING ON OPPOSITE SIDE.

CURB & GUTTER

NOTES:

- 1. SEE ANGLE PARKING ORDINANCE FOR OTHER REQUIREMENTS FOR ANGLE PARKING.



ENOCH CITY
900 E MIDVALLEY RD
Enoch, UT 84721
Tel. (435) 586-1119

ANGLE PARKING
STALL PAVEMENT
MARKING DETAIL

SCALE:
N.T.S.
DATE:
DEC. 2022

DETAIL No.:

R15.0

SHEET:
1 of 1

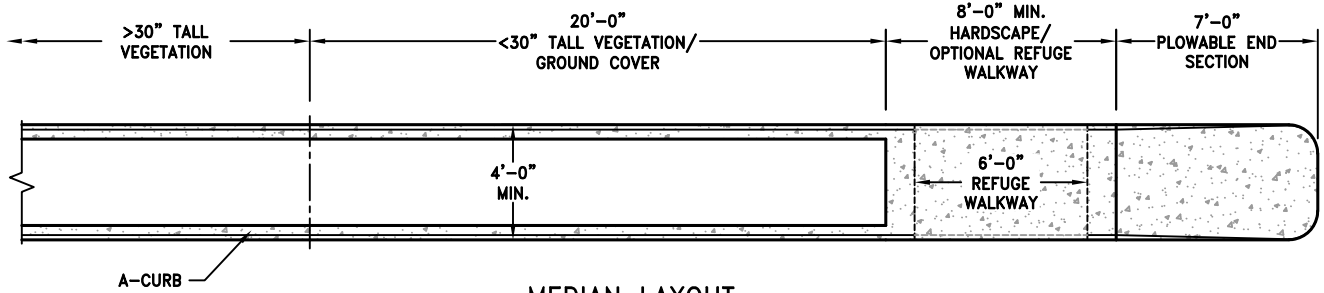

MEDIAN LAYOUT

N.T.S.

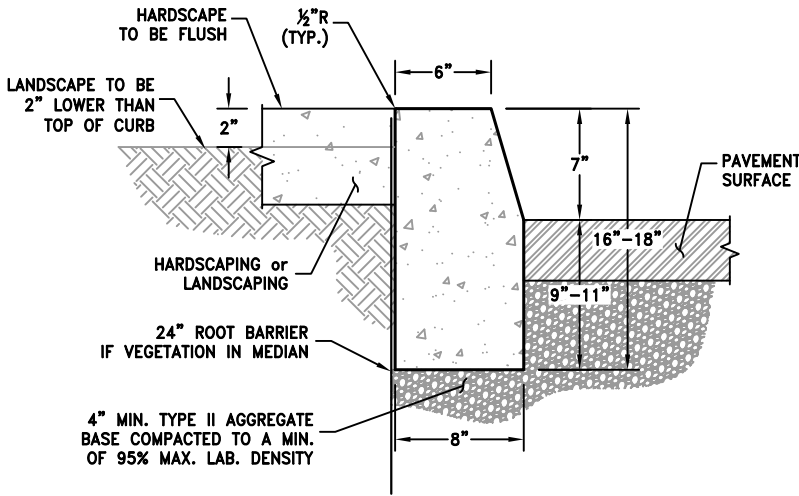

A-CURB DETAIL

N.T.S.

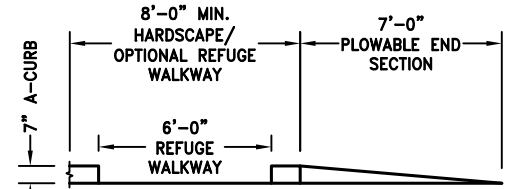

WALKWAY & PLOWABLE END PROFILE

N.T.S.

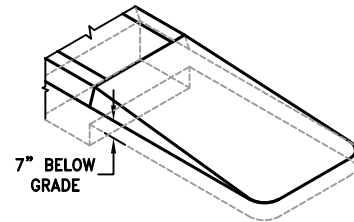

PLOWABLE END DETAIL

N.T.S.

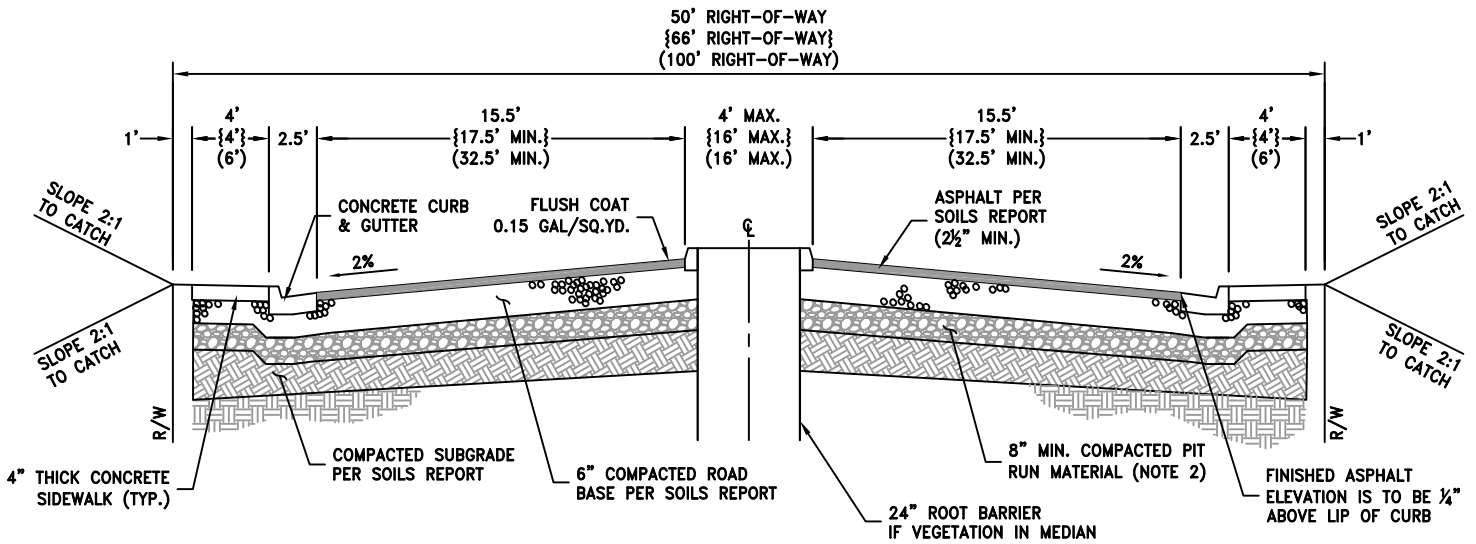

TYPICAL MEDIAN ROAD SECTION

50' RIGHT-OF-WAY
{66' RIGHT-OF-WAY}
(100' RIGHT-OF-WAY)

NOTES:

1. BACK OF SIDEWALK TO BE BACKFILLED TO TOP OF CONCRETE.
2. PIT RUN MATERIAL CAN BE ELIMINATED IF NATIVE MATERIAL MEETS OR EXCEEDS PIT RUN MATERIAL STANDARD GRADATION.
3. MEDIAN VEGETATION PER ISLAND OWNER.
4. VEGETATION FOR MEDIAN LANDSCAPING TO FOLLOW APPROVED ENOCH CITY VEGETATION ORDINANCE.



ENOCH CITY
900 E MIDVALLEY RD
Enoch, UT 84721
Tel. (435) 586-1119

**CENTER LANDSCAPED
MEDIAN DETAIL**

SCALE:
N.T.S.
DATE:
DEC. 2022

DETAIL No.:

R16.0

SHEET:
1 of 1

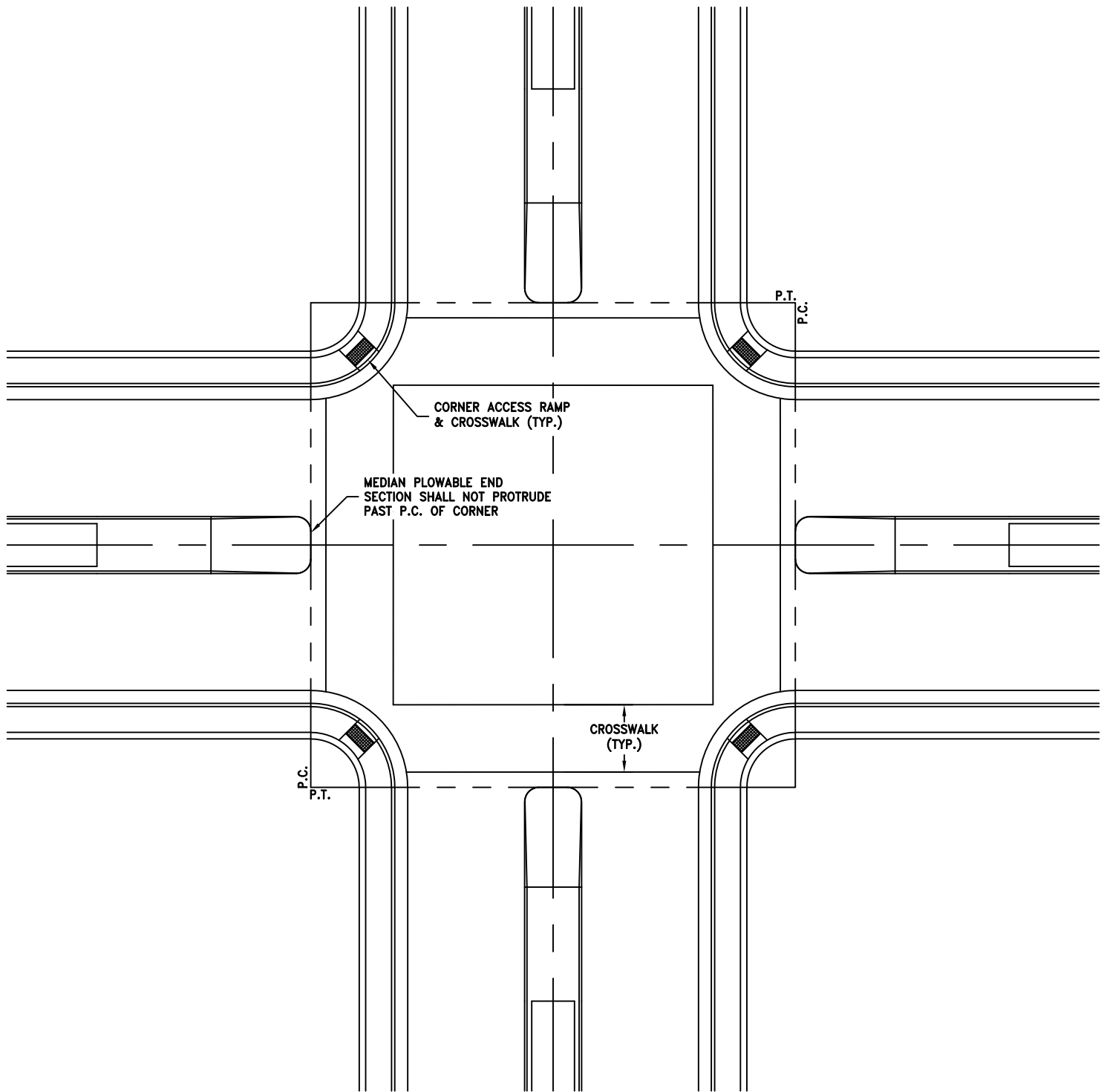

TYPICAL MEDIAN INTERSECTION DETAIL
N.T.S.

NOTES:

1. REFER TO ENOCH CITY STANDARD DETAIL R16.0 FOR MEDIAN DESIGN REQUIREMENTS.



ENOCH CITY
900 E MIDVALLEY RD
Enoch, UT 84721
Tel. (435) 586-1119

MEDIAN INTERSECTION
w/ CORNER ACCESS
RAMP

SCALE:
N.T.S.
DATE:
DEC. 2022

DETAIL No.:

R17.1

SHEET:
1 of 1

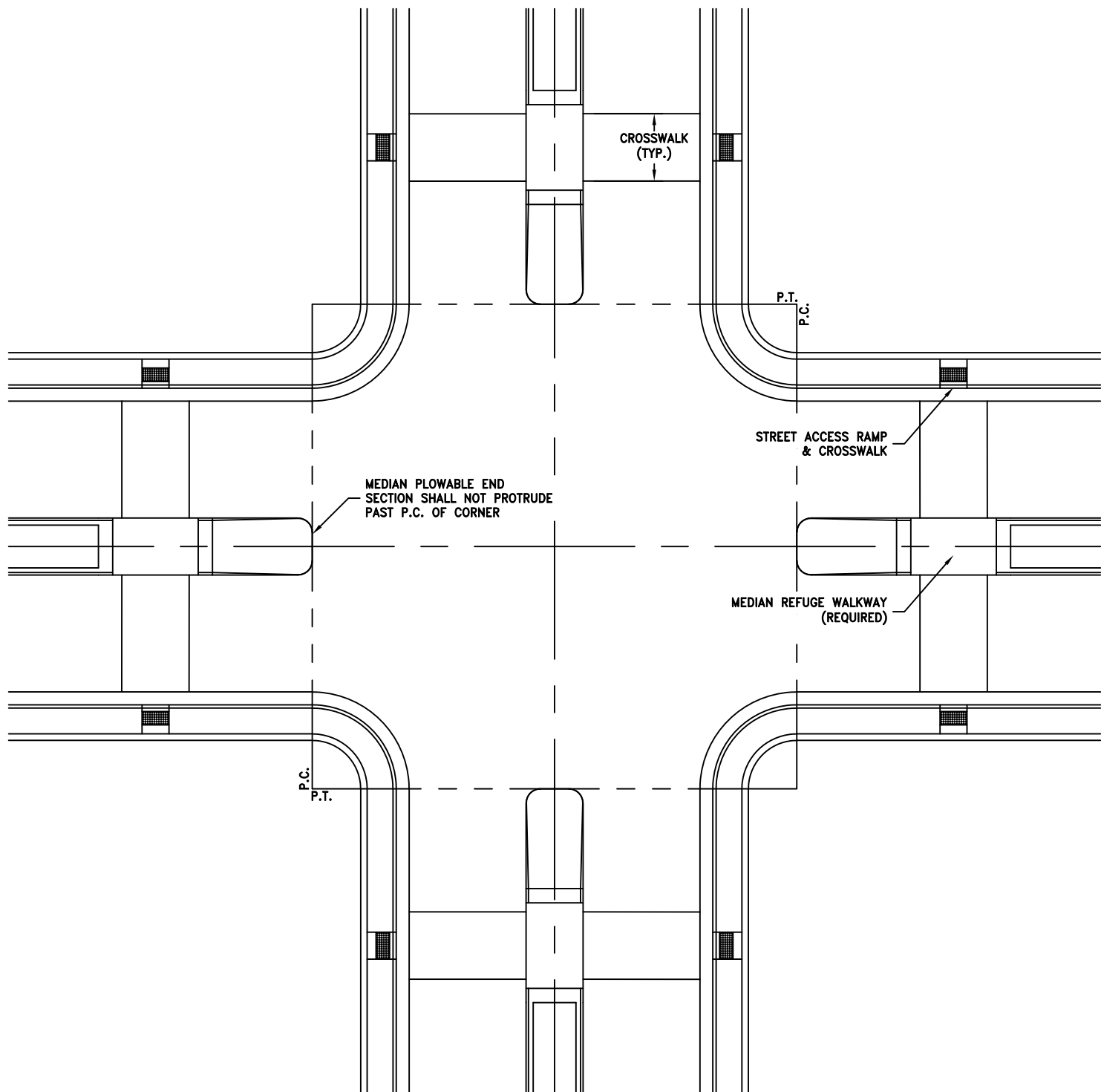

TYPICAL MEDIAN INTERSECTION DETAIL
N.T.S.

NOTES:

1. REFER TO ENOCH CITY STANDARD DETAIL R16.0 FOR MEDIAN DESIGN REQUIREMENTS.



ENOCH CITY
900 E MIDVALLEY RD
Enoch, UT 84721
Tel. (435) 586-1119

MEDIAN INTERSECTION
w/ STREET ACCESS
RAMP DETAIL

SCALE:
N.T.S.
DATE:
DEC. 2022

DETAIL No.:

R17.2

SHEET:
1 of 1

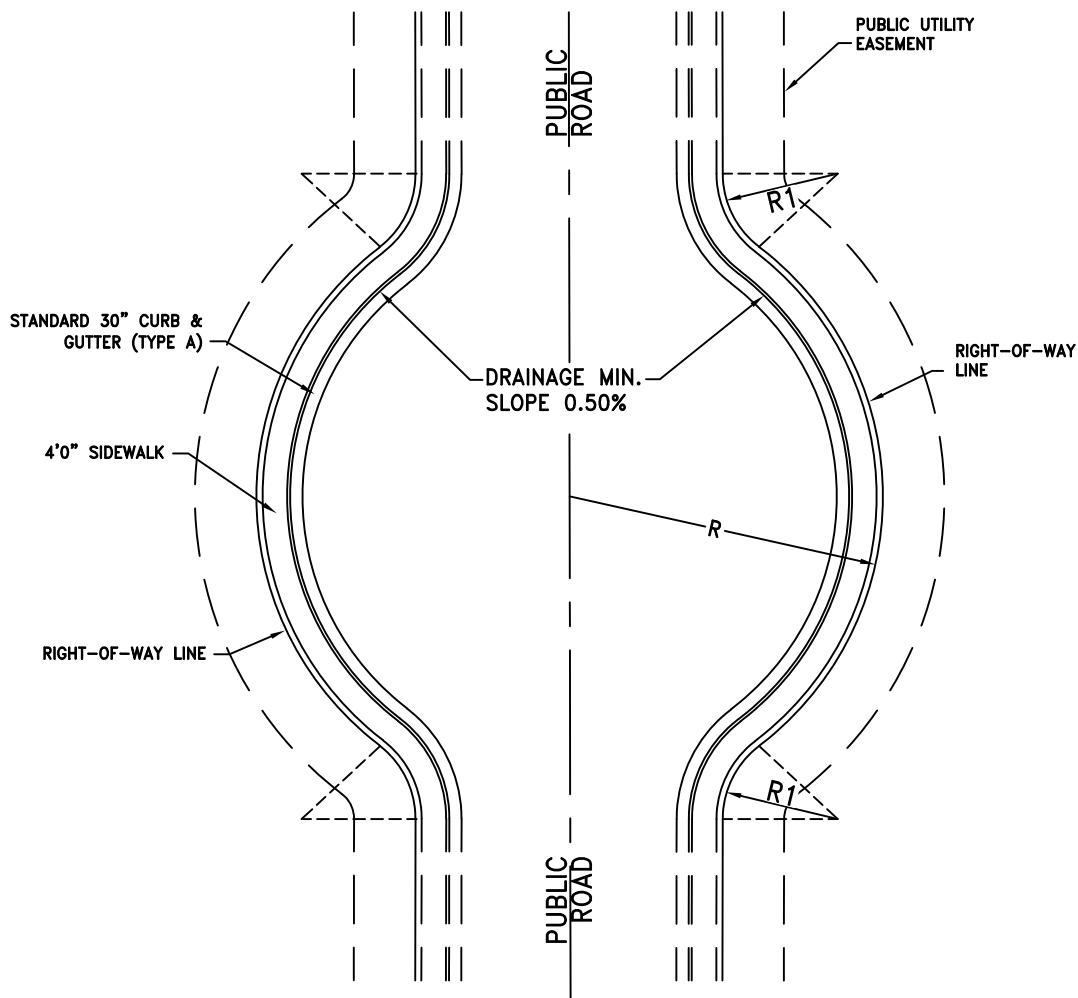

NOTES:

1. ROAD SECTIONS SHALL BE THE SAME ROAD SECTION AS RECOMMENDED BY THE GEOTECHNICAL ENGINEER.

R/W WIDTH	W	R (MIN.)	R1 (MIN.)
50'	40'	55'	15'
66'	56'	60'	20'
100'	86'	60'	35'



ENOCH CITY
 900 E MIDVALLEY RD
 Enoch, UT 84721
 Tel. (435) 586-1119

BULB ROAD DETAIL

SCALE:
 N.T.S.
 DATE:
 DEC. 2022

DETAIL No.:

R18.0

SHEET:
 1 of 1

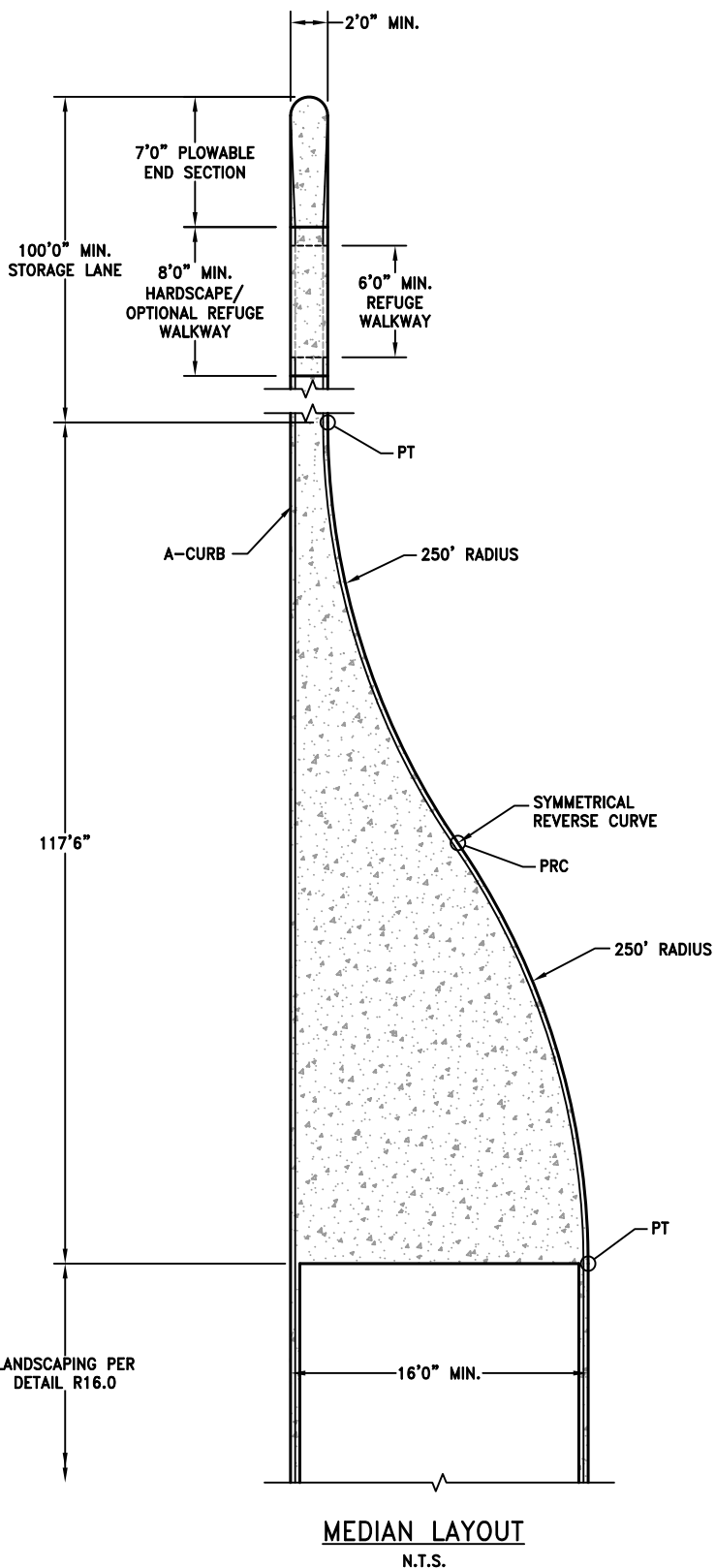

MEDIAN LAYOUT
N.T.S.

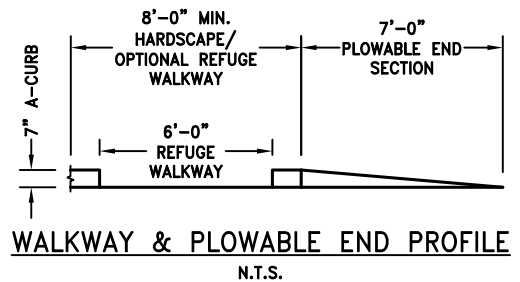

WALKWAY & PLOWABLE END PROFILE
N.T.S.

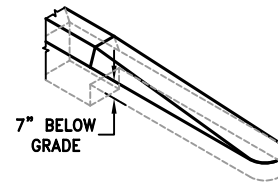

PLOWABLE END DETAIL
N.T.S.

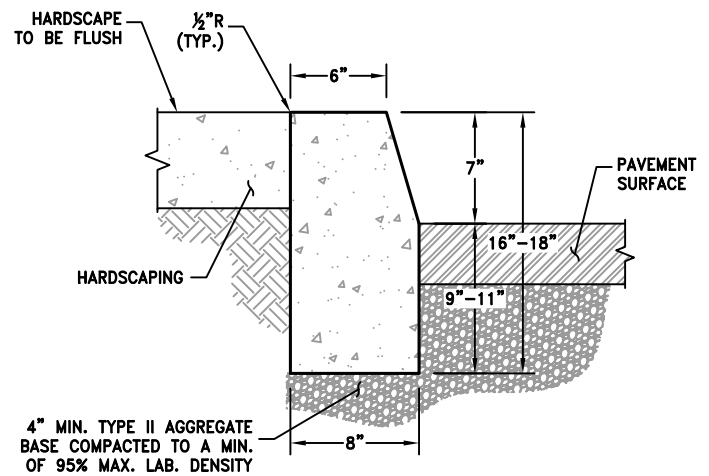

A-CURB DETAIL
N.T.S.

NOTES:

1. BACK OF SIDEWALK TO BE BACKFILLED TO TOP OF CONCRETE.
2. PIT RUN MATERIAL CAN BE ELIMINATED IF NATIVE MATERIAL MEETS OR EXCEEDS PIT RUN MATERIAL STANDARD GRADATION.
3. MEDIAN VEGETATION PER ISLAND OWNER.
4. VEGETATION FOR MEDIAN LANDSCAPING TO FOLLOW APPROVED ENOCH CITY VEGETATION ORDINANCE.
5. REQUIRED ON ALL MAJOR COLLECTOR ROADS WITH MEDIANS.



ENOCH CITY
900 E MIDVALLEY RD
Enoch, UT 84721
Tel. (435) 586-1119

66' & 100' R.O.W.
LEFT TURN MEDIAN
DETAIL

SCALE:
N.T.S.
DATE:
DEC. 2022

DETAIL No.:

R19.0

SHEET:
1 of 1

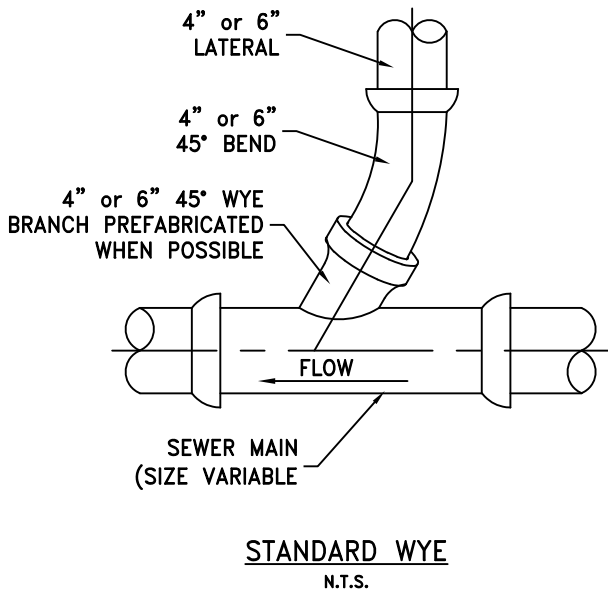
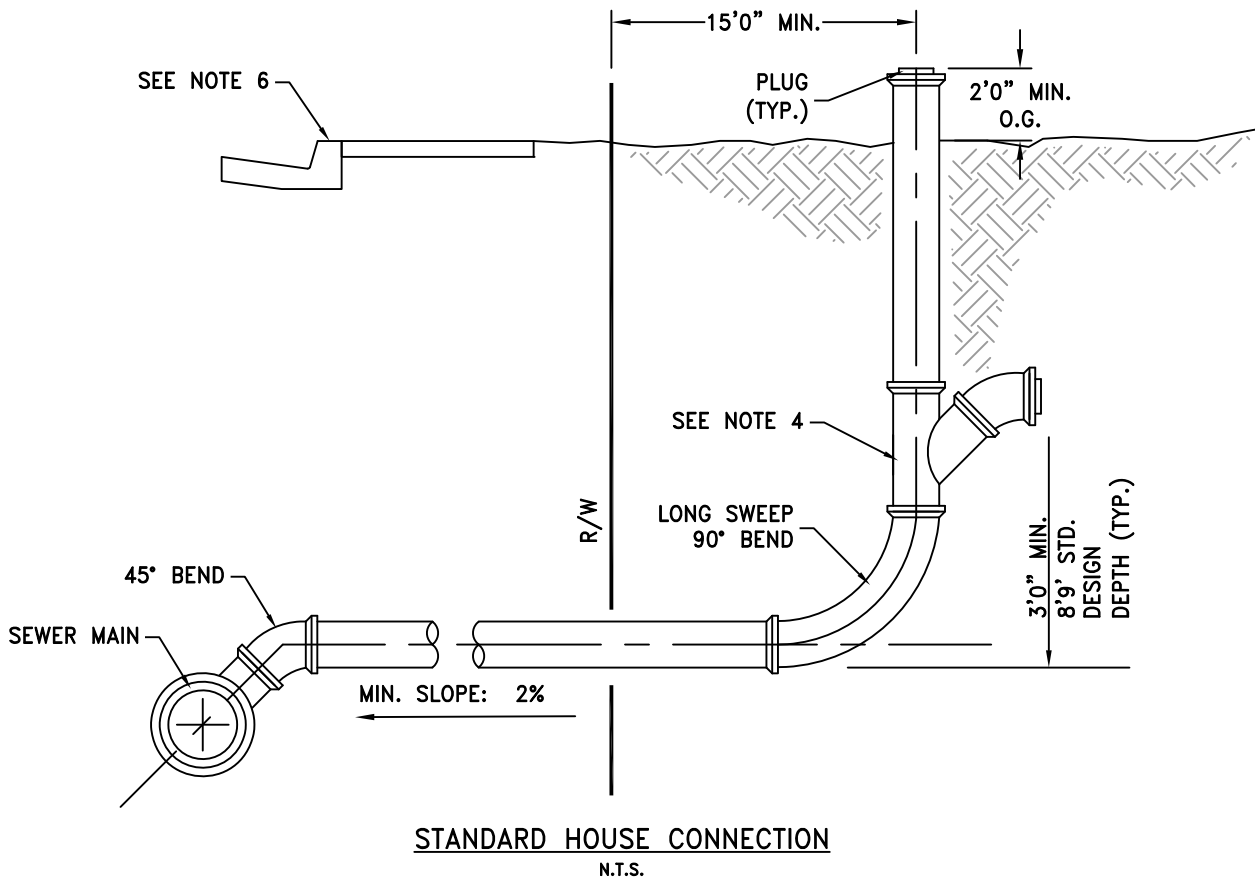

NOTES:

1. ONLY APPROVED INSERTABLE TEES w/ RUBBER GROMMET SEAL or PVC SADDLE WYES GLUED & STRAPPED TO EXISTING PVC MAINS ALLOWED. INSERTABLE TEES SHALL NOT BE USED IN PIPE LESS THAN 12"Ø. SADDLE WYES CONNECTING TO VITRIFIED CLAY SEWER PIPE MAIN MUST BE ENCASED IN CRUSHED STONE AS SHOWN.
2. ALL SEWER LATERALS TO BE ABS or PVC 4" or 6"Ø MATERIAL SDR-35.
3. WHERE CLEARANCE BETWEEN BOTTOM OF OBSTRUCTION AND TOP OF LATERAL IS LESS THAN 12", ENCASE LATERAL IN CRUSHED STONE.
4. 4" or 6" PVC WYE INSTALLED BY BUILDING PLUMBER AT REQUIRED ELEVATIONS.
5. SEWER LATERALS SHALL NORMALLY BE PLACED 10'0" INSIDE THE SIDE LOT LINE ON THE SIDE WHERE THE SEWER MAIN IS THE LOWEST. ON TWIN HOME LOTS SEWER LATERAL SHALL BE PLACED 1'0" ON EACH SIDE OF THE LINE DIVIDING THE HOMES.
6. 4" HIGH LETTER "S" ETCHED IN CONCRETE CURB ABOVE SEWER LATERAL.
7. NO SEWER LATERALS SHALL BE CONNECTED DIRECTLY TO SEWER MANHOLES.
8. WHEN A NEW SEWER LATERAL REPLACES AN EXISTING SEWER LATERAL AT A DIFFERENT LOCATION ON THE SEWER MAIN, THE EXISTING SEWER LATERAL SHALL BE CAPPED AT THE SEWER MAIN.
9. SEWER LATERALS IN COMMERCIAL PARKING LOTS REQUIRE A COLLAR AROUND THE CLEAN-OUT CAP SIMILAR TO WATER VALVE BOX COLLARS PER DETAIL W1.1

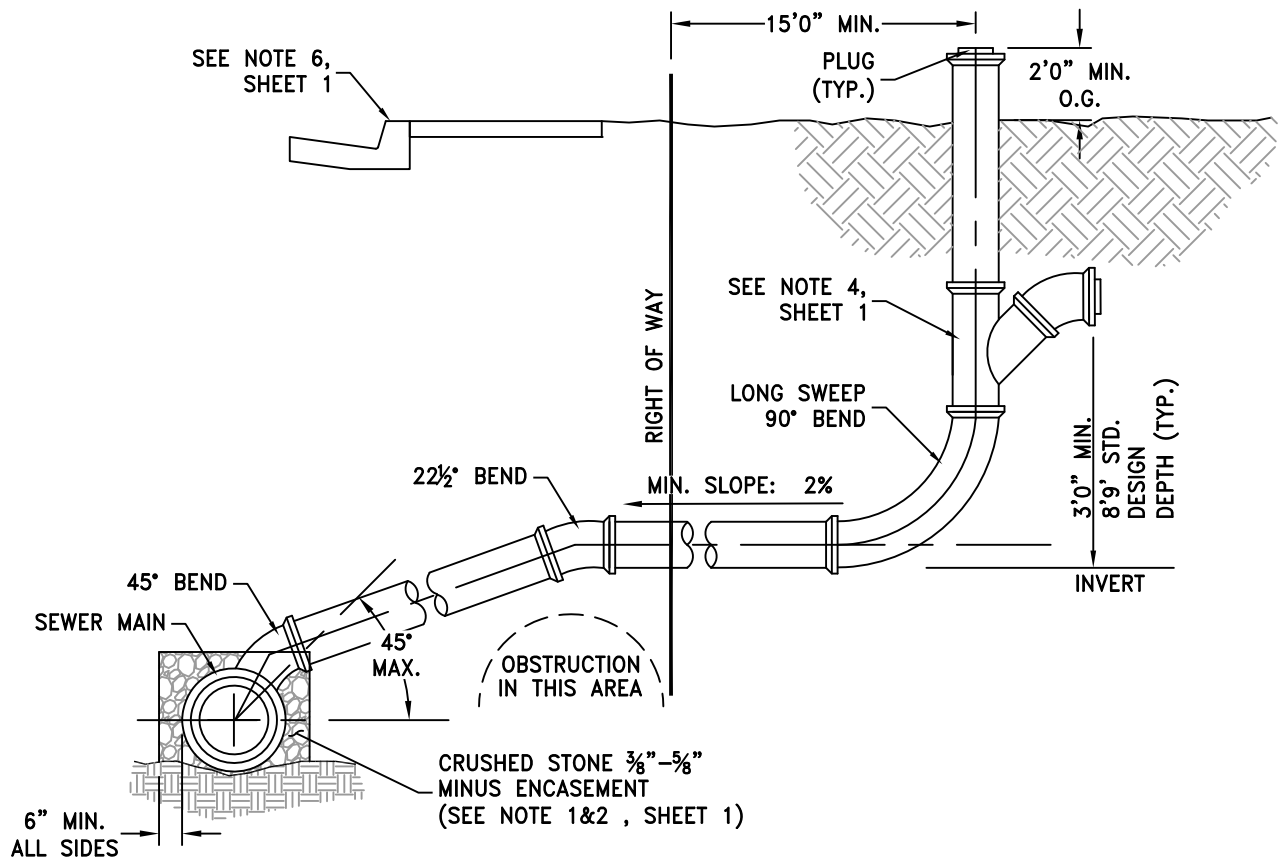

HOUSE CONNECTION OVER OBSTRUCTION

(UPON APPROVAL ONLY)
N.T.S.

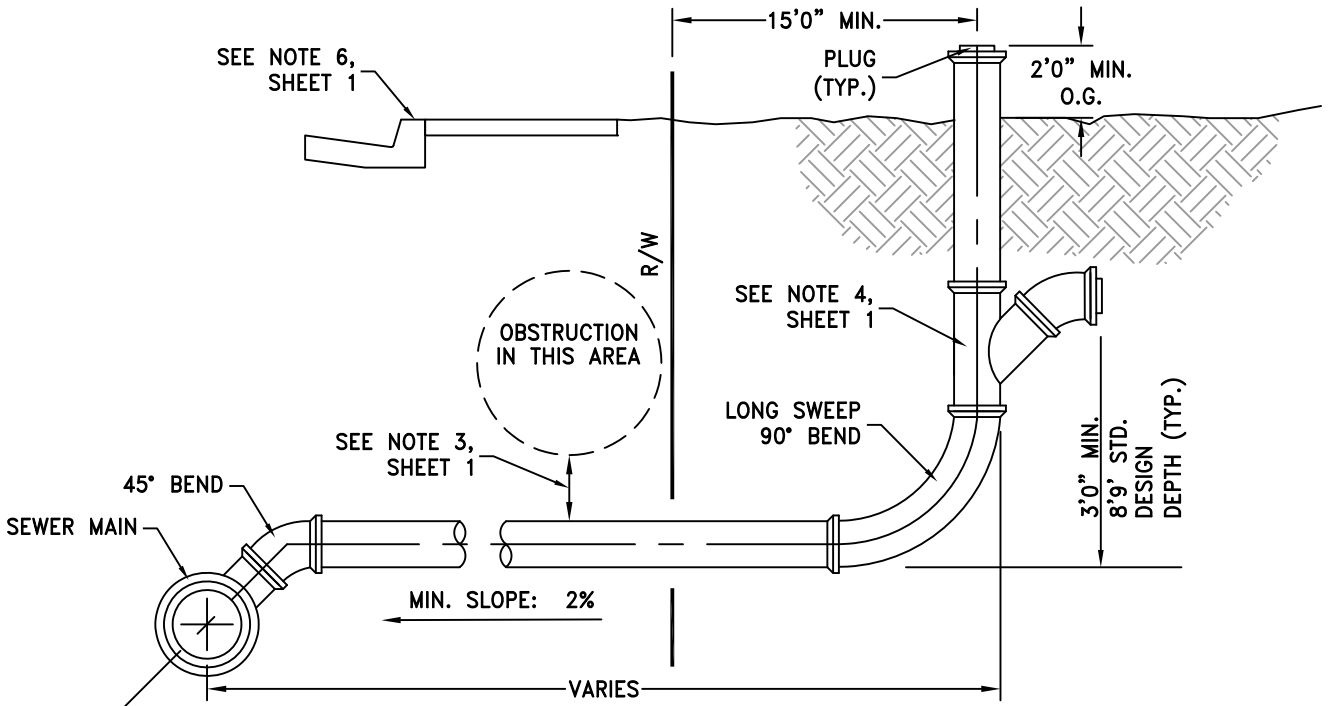

HOUSE CONNECTION UNDER OBSTRUCTION

(UPON APPROVAL ONLY)
N.T.S.



ENOCH CITY
900 E MIDVALLEY RD
Enoch, UT 84721
Tel. (435) 586-1119

SEWER LATERAL

SCALE:
N.T.S.
DATE:
DEC. 2022

DETAIL No.:

S1.0B

SHEET:
2 of 2

4'0" DIAMETER or SQUARE CONCRETE COLLAR w/ #4 BAR AND REINFORCEMENT FIBERS. 8" THICK MIN. w/ GRADE RING ENCASUREMENT (SEE NOTES 1,2&7)

D&L MANHOLE RING AND COVER NO. A-1180 (RIBLESS) CROSS HATCH DESIGN (O.A.E.) w/ "SEWER" LETTERING. NO LOW PROFILE LIDS WILL BE ALLOWED.

PRECAST CONCRETE GRADE RINGS or 30" I.D. CORRUGATED POLYETHYLENE PIPE ENCASED IN CONCRETE COLLAR (12" MAX. HEIGHT)

PRECAST ECCENTRIC CONE w/ 30" OPENING or REGULAR MANHOLE SECTION w/ TRAFFIC LID.

SEAL ALL JOINTS w/ "RAM-NEK" or NON-SHRINK GROUT or ASPHALTIC SEALER AND GASKET INCLUDING JOINTS BETWEEN GRADE ADJUSTING RINGS AND JOINT BETWEEN MANHOLE RING AND CONCRETE ON MANHOLES WITH NO CONCRETE COLLAR. SEALER TO BE PLACED ON INSIDE OF MANHOLE JOINT AND VISIBLE FROM INSIDE MANHOLE.

M.A. MANHOLE STEP (M.A. INDUSTRIES INC.) or APPROVED EQUAL

PRECAST OR CAST-IN-PLACE CONCRETE BASE & FOOTING SLOPE INSIDE TO PIPE ALL AROUND

FORM CHANNEL IN CONCRETE BASE OPENING MUST BE AT LEAST AS WIDE AS THE PIPE INSIDE DIAMETER.

BASE TO REST ON UNDISTURBED EARTH or 12" MIN. OF 1" MAX. GRADED ROCK

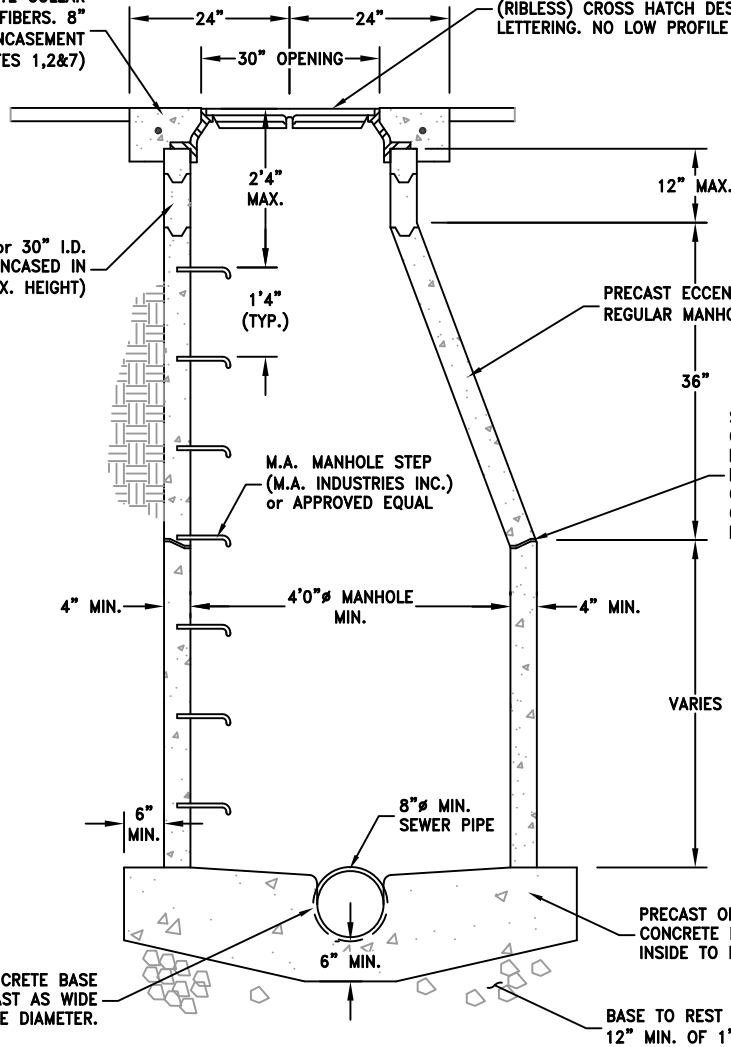

SECTION
N.T.S.

TYPICAL MANHOLE FOR SANITARY SEWER
N.T.S.

NOTES:

1. MANHOLES IN ROADWAYS REQUIRE CONCRETE COLLAR. TOP OF MANHOLE CONE IN UNIMPROVED AREAS SHALL BE SET 6" TO 12" ABOVE FINISH GRADE WITH NO GRADE RINGS. (NO CONCRETE COLLAR REQUIRED)
2. MANHOLE LID, RING AND CONCRETE COLLAR TO BE CENTERED ON MANHOLE OPENING AND SET 1/4" BELOW TOP OF ASPHALT.
3. 5'0"Ø MANHOLES REQUIRED FOR ALL SEWER LINES OVER 15"Ø, MANHOLES OVER 12'0" DEEP, or MANHOLES w/ (3) or MORE INCOMING LINES.
4. NO SEWER LATERALS SHALL BE INSTALLED INTO MANHOLES.
5. OUTLET PIPE INVERT TO BE 0.05' (MINIMUM) LOWER THAN INLET PIPES IN ALL MANHOLES.
6. NO WOOD OR PVC SHIMS WILL BE ALLOWED BETWEEN LID RING AND ADJUSTING RINGS OR MANHOLE.
7. IF TRAFFIC LID IS USED, CONCRETE COLLAR CAN BE ELIMINATED IF TRAFFIC LID IS < 6" BELOW FINISHED ROAD GRADE.
8. MANHOLES IN UNIMPROVED AREAS REQUIRE AN ORANGE CARSONITE CRM 66" UTILITY MARKER BE PLACED WITHIN 4'0" OF THE MANHOLE w/ A STICKER INDICATING SEWER MANHOLE.
9. DROP MANHOLE AND ALL OTHER MANHOLES WITH PRESSURE LINE OF ANY SIZE or GRAVITY LINES 15"Ø AND ABOVE SHALL BE CORROSION RESISTANT, ARMOR ROCK (PRECAST), or SPRAYROQ (FIELD APPLIED); 125 MILS. THICK, O.A.E.



ENOCH CITY
900 E MIDVALLEY RD
Enoch, UT 84721
Tel. (435) 586-1119

NEW SEWER MANHOLE
& EXISTING
CONNECTION

SCALE:
N.T.S.
DATE:
DEC. 2022

DETAIL No.:

S2.0A

SHEET:
1 of 2

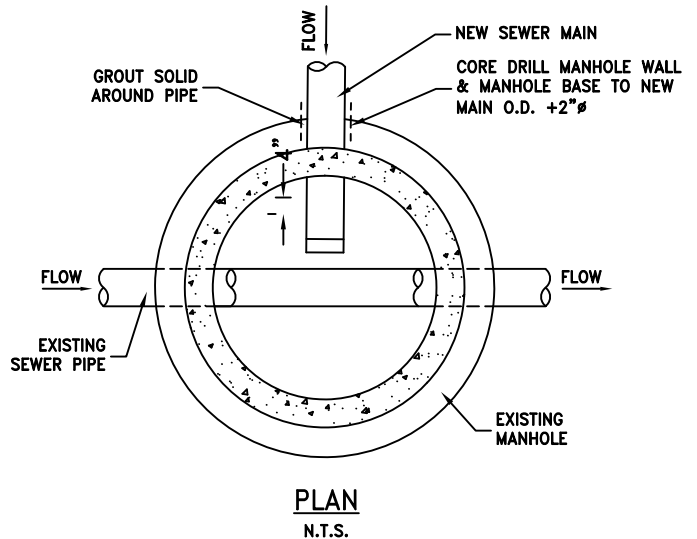
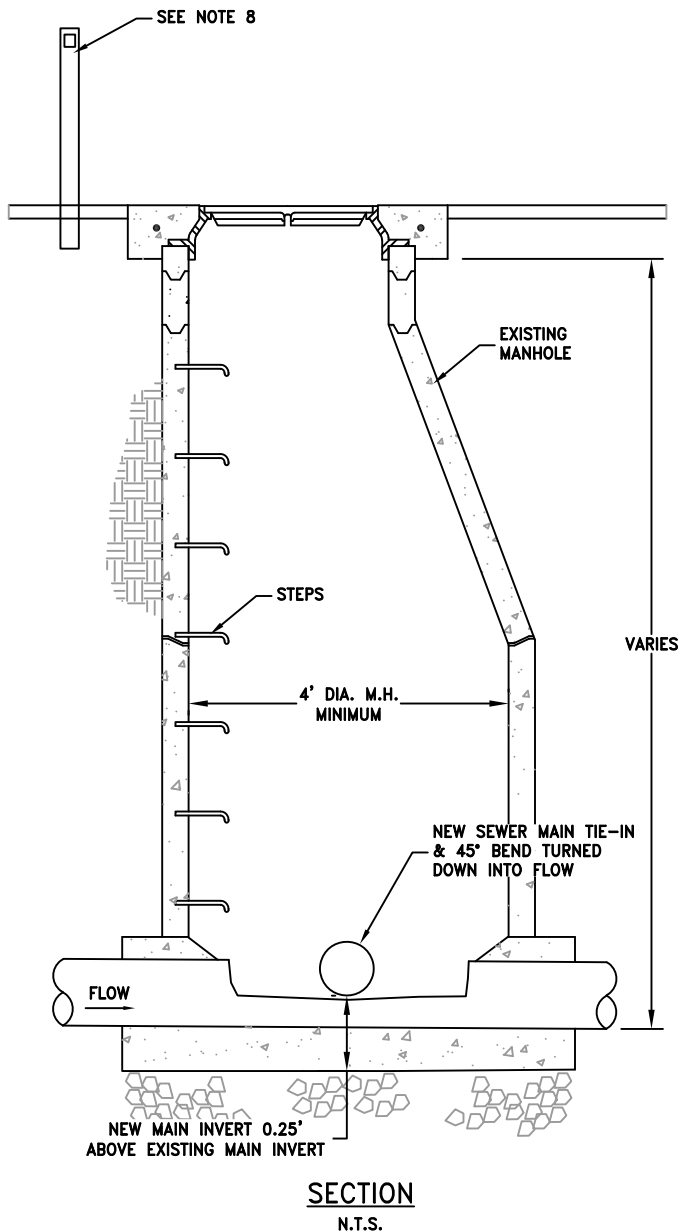

EXISTING SEWER MANHOLE CONNECTION
N.T.S.

NOTES:

1. MANHOLES IN ROADWAYS REQUIRE CONCRETE COLLAR. TOP OF MANHOLE CONE IN UNIMPROVED AREAS SHALL BE SET 6" TO 12" ABOVE FINISH GRADE WITH NO GRADE RINGS. (NO CONCRETE COLLAR REQUIRED)
2. MANHOLE LID, RING AND CONCRETE COLLAR TO BE CENTERED ON MANHOLE OPENING AND SET 1/4" BELOW TOP OF ASPHALT.
3. 5'0" ϕ MANHOLES REQUIRED FOR ALL SEWER LINES OVER 15" ϕ , MANHOLES OVER 12'0" DEEP, or MANHOLES w/ (3) or MORE INCOMING LINES.
4. NO SEWER LATERALS SHALL BE INSTALLED INTO MANHOLES.
5. OUTLET PIPE INVERT TO BE 0.05' (MINIMUM) LOWER THAN INLET PIPES IN ALL MANHOLES.
6. NO WOOD OR PVC SHIMS WILL BE ALLOWED BETWEEN LID RING AND ADJUSTING RINGS OR MANHOLE.
7. IF TRAFFIC LID IS USED, CONCRETE COLLAR CAN BE ELIMINATED IF TRAFFIC LID IS < 6" BELOW FINISHED ROAD GRADE.
8. MANHOLES IN UNIMPROVED AREAS REQUIRE AN ORANGE CARSONITE CRM 66" UTILITY MARKER BE PLACED WITHIN 4'0" OF THE MANHOLE w/ A STICKER INDICATING SEWER MANHOLE.
9. DROP MANHOLE AND ALL OTHER MANHOLES WITH PRESSURE LINE OF ANY SIZE or GRAVITY LINES 15" ϕ AND ABOVE SHALL BE CORROSION RESISTANT, ARMOR ROCK (PRECAST), or SPRAYROQ (FIELD APPLIED); 125 MILS. THICK, O.A.E.



ENOCH CITY
900 E MIDVALLEY RD
Enoch, UT 84721
Tel. (435) 586-1119

NEW SEWER MANHOLE
& EXISTING
CONNECTION

SCALE:
N.T.S.
DATE:
DEC. 2022

DETAIL No.:

S2.0B

SHEET:
2 of 2

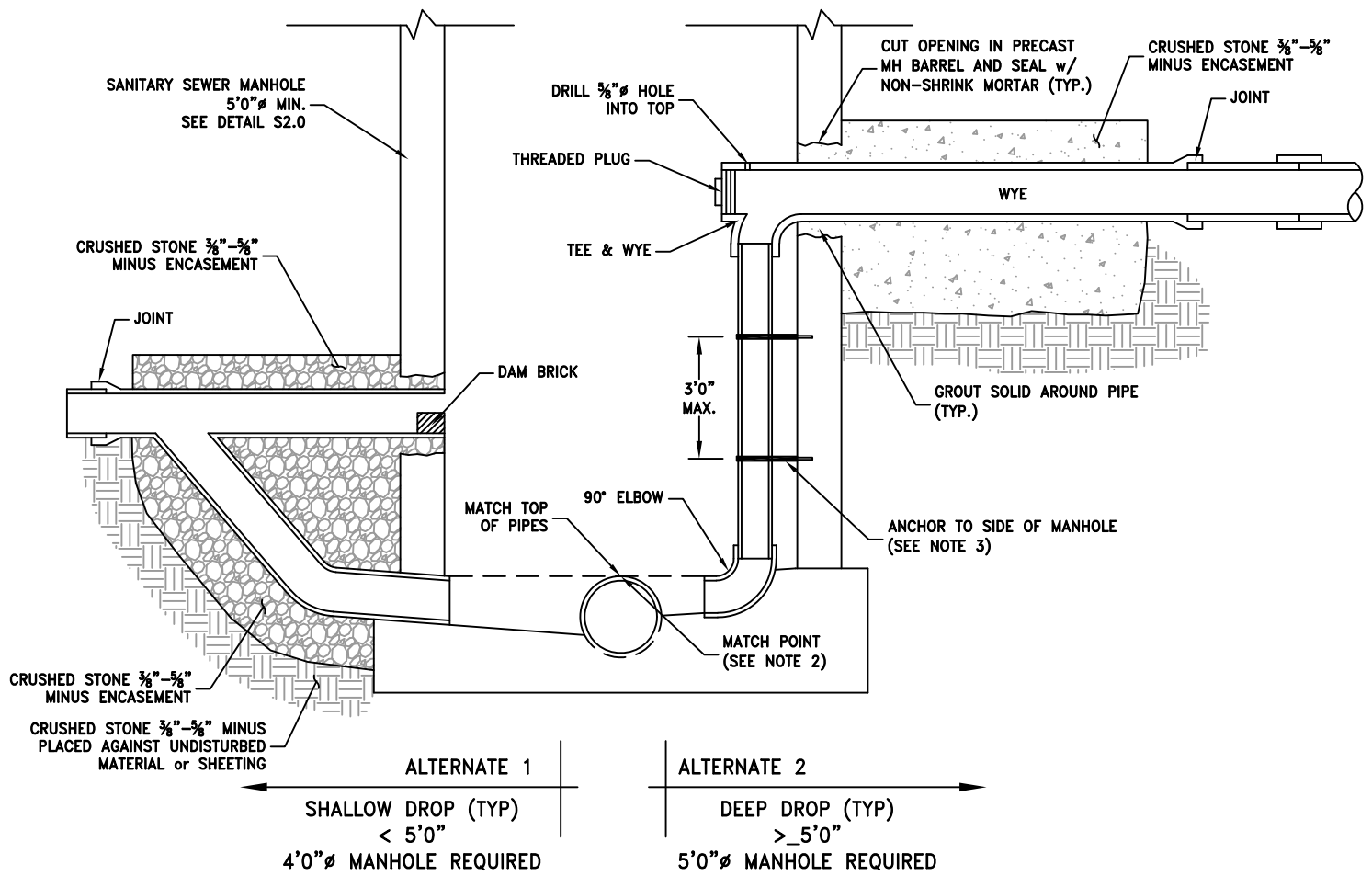

SECTION
N.T.S.

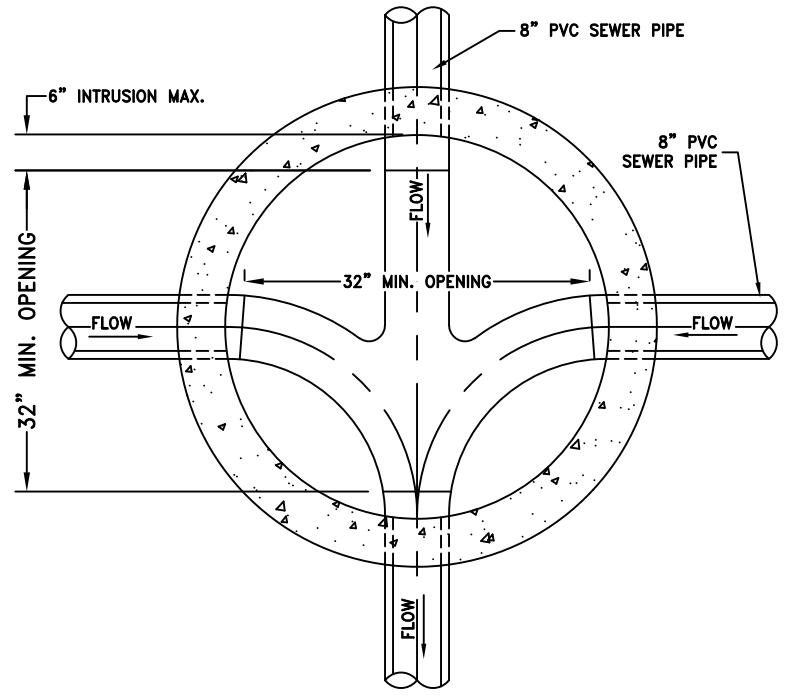

NOTES:

1. PIPE DROPS: ONLY ONE DROP PIPE IS ALLOWED INSIDE THE MANHOLE. SIZE THE DROP PIPE TO BE SAME DIAMETER AS SEWER PIPE DISCHARGING INTO MANHOLE.
2. MATCH POINT: MATCH TOP OF THE PIPES.
3. ANCHOR: IF THE DROP IS MORE THAN 18", ANCHOR THE RISER TO THE WALL EVERY 36". USE CONCRETE ANCHORS 1 1/2" THREADED RODS, AWI PIPE HANGERS w/ 1/2" COUPLING & POLY PROYLENE COLLAR. ALL STEEL SHALL BE 304 STAINLESS.
4. ALL MANHOLES WITH SEWER LINES 15"Ø or GREATER NEED TO HAVE CONCRETE ACID RESISTANT COATING ARMOR ROQ (PRECAST) or SPRAYROQ (FIELD APPLIED), 125 MILS. THICK, O.A.E.



ENOCH CITY
900 E MIDVALLEY RD
Enoch, UT 84721
Tel. (435) 586-1119

DROP MANHOLE

SCALE: N.T.S.
DATE: DEC. 2022
DETAIL No.: S3.0
SHEET: 1 of 1

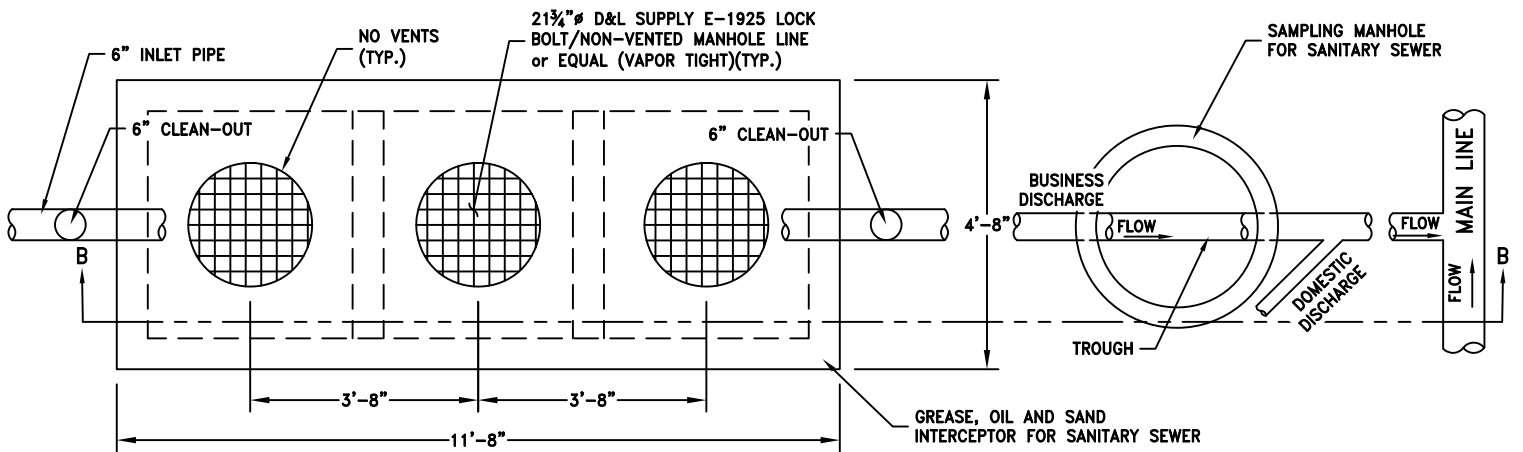

TOP VIEW
N.T.S.

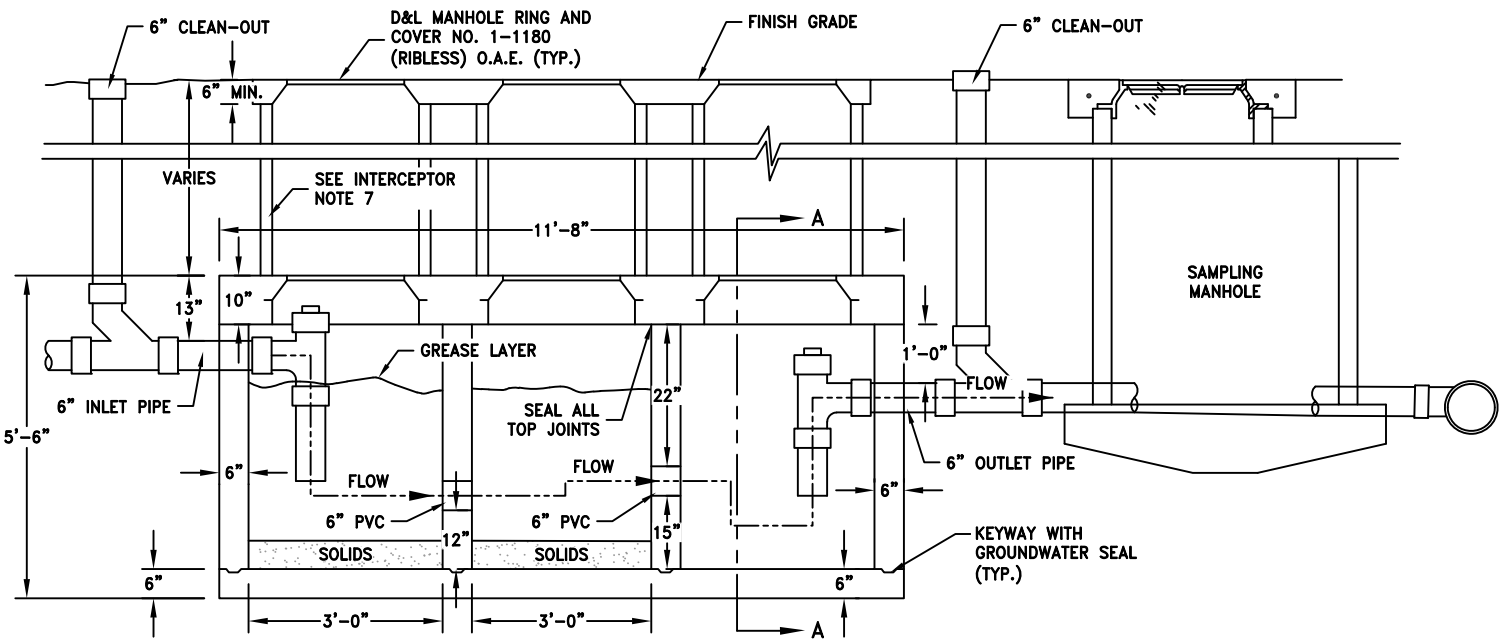

SECTION B-B
N.T.S.

INTERCEPTOR NOTES:

1. MATERIAL SPEC'S:
 - 1.A. CONCRETE PORTLAND CEMENT TYPE II. MINIMUM COMPRESSIVE STRENGTH=4000 PSI AT 28 DAYS.
 - 1.B. REINFORCING BAR INTERMEDIATE GRADE 40 ASTM A615.
 - 1.C. REINFORCING WELDED WIRE MESH ASTM A185.
2. UNIT COATED OUTSIDE WITH AN APPROVED PROTECTIVE COATING.
3. ALL DIMENSIONS ± NOT TO BE USED FOR CONSTRUCTION PURPOSES UNLESS CERTIFIED.
4. PRECAST UNIT TO BE PLACED ON NATURAL SOIL or APPROVED COMPACTED FILL.
5. STANDARD GROUND WATER SEAL-BUTYL ROPE MASTIC or CEMENT MORTAR.
6. INTERCEPTOR MANHOLE COVERS TO BE SET FLUSH WITH ASPHALT or CONCRETE PARKING LOT GRADES or 6" MIN. ABOVE GRADE IN UNFINISHED or LANDSCAPE AREAS.
7. RAISE COVERS TO FINISHED GRADE WITH 30" I.D. CONCRETE or HDPE PIPE (TYP.)

SAMPLING MANHOLE NOTES:

1. MANHOLES IN ROADWAYS or PARKING LOTS REQUIRE CONCRETE COLLAR. MANHOLES IN UNIMPROVED AREAS SHALL BE SET 6" ABOVE. FINISH GRADE. (NO CONC. COLLAR REQUIRED)
2. MANHOLE LID, RING AND CONCRETE COLLAR TO BE SET 1/4" BELOW TOP OF ASPHALT.

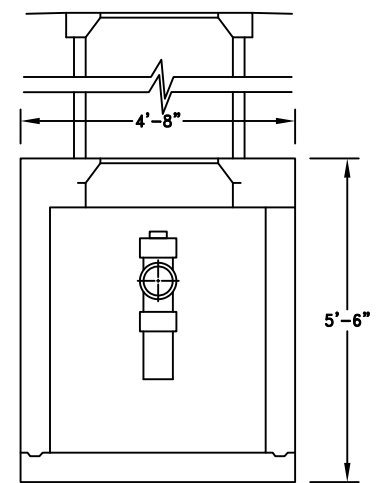

SECTION A-A
N.T.S.



ENOCH CITY
900 E MIDVALLEY RD
Enoch, UT 84721
Tel. (435) 586-1119

**GREASE, OIL & SAND
INTERCEPTOR &
SAMPLING MANHOLE
FOR SANITARY SEWER**

SCALE:
N.T.S.
DATE:
DEC. 2022

DETAIL No.:

S4.0

SHEET:
1 of 1

GAS HEATER w/ ADJUSTABLE THERMOSTAT A HIGH CAPACITY STATION HEATER SHALL BE PROVIDED FOR THE PROTECTION OF THE PUMPING EQUIPMENT.

WALL MOUNTED DUPLEX GFI UTILITY RECEPTACLE PROVIDING 120 VOLT AC POWER (4 EACH, TYP.) (ONE ON EACH INTERIOR WALL)

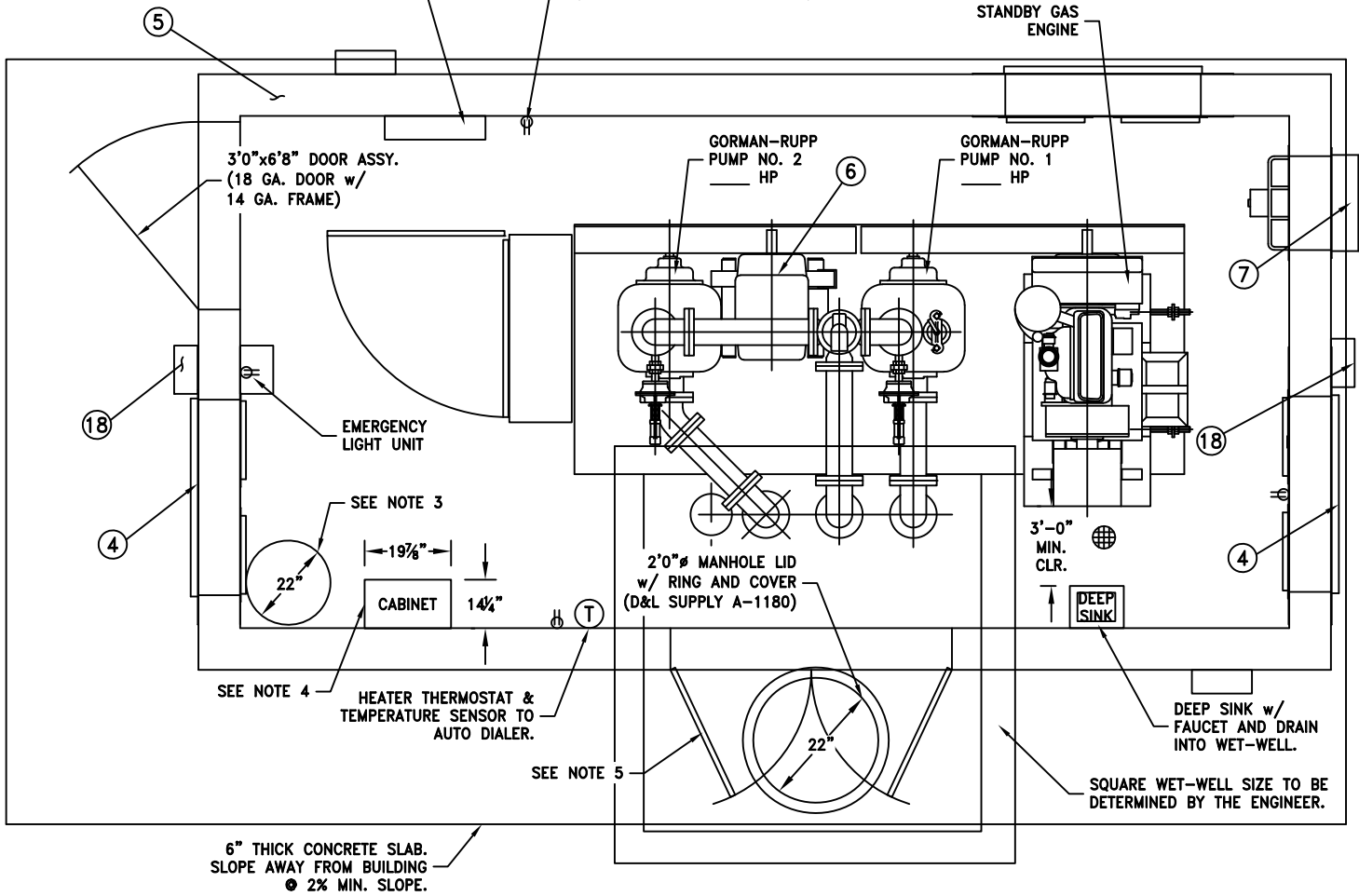

PLAN VIEW
N.T.S.

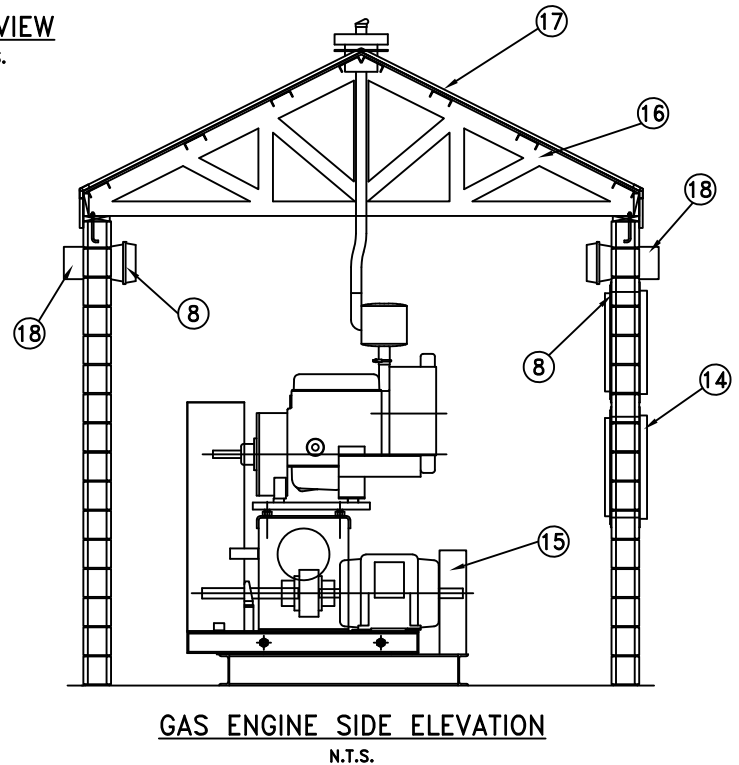

GAS ENGINE SIDE ELEVATION
N.T.S.

NOTES:

1. EXTERNAL SECURITY LIGHTS (4 EACH, TYP.) 120V AC PHOTOELECTRIC HIGH PRESSURE SODIUM LIGHT, MOUNTED AND WIRED TO EXTERIOR WALL (ONE ON EACH EXTERIOR WALL.)
2. 4" FLOOR DRAIN. DRAIN INTO WET-WELL. SLOPE CONCRETE FLOOR INSIDE THE BUILDING TO THE FLOOR DRAIN.
3. PROVIDE TRASH CAN (RUBBERMAID 32 GAL. BRUTE ROUND BASE w/ BRUTE DOME TOP - GRAY COLOR)
4. WALL-MOUNTED STEEL STORAGE CABINET (DURHAM MODEL 056) 2 ADJUSTABLE SHELVES. RUST AND ACID-RESISTANT BAKED ENAMEL FINISH.
5. DOUBLE-WIDE ENTRANCE DOOR 6'0"x6'8" DOOR ASSEMBLY WITHOUT A CENTER SILL. (18 GA. DOOR W/ 14 GA. FRAME) w/ PUSH PULL HARDWARE, DEAD BOLT & 3 HINGES.
6. SEE S5.0C; SHEET 3 FOR CONSTRUCTION NOTES.
7. SEE S5.0D; SHEET 4 FOR GENERAL NOTES.



ENOCH CITY
900 E MIDVALLEY RD
Enoch, UT 84721
Tel. (435) 586-1119

SELF PRIMING
SEWER LIFT STATION

SCALE:
N.T.S.
DATE:
DEC. 2022

DETAIL No.:

S5.0A

SHEET:
1 of 4

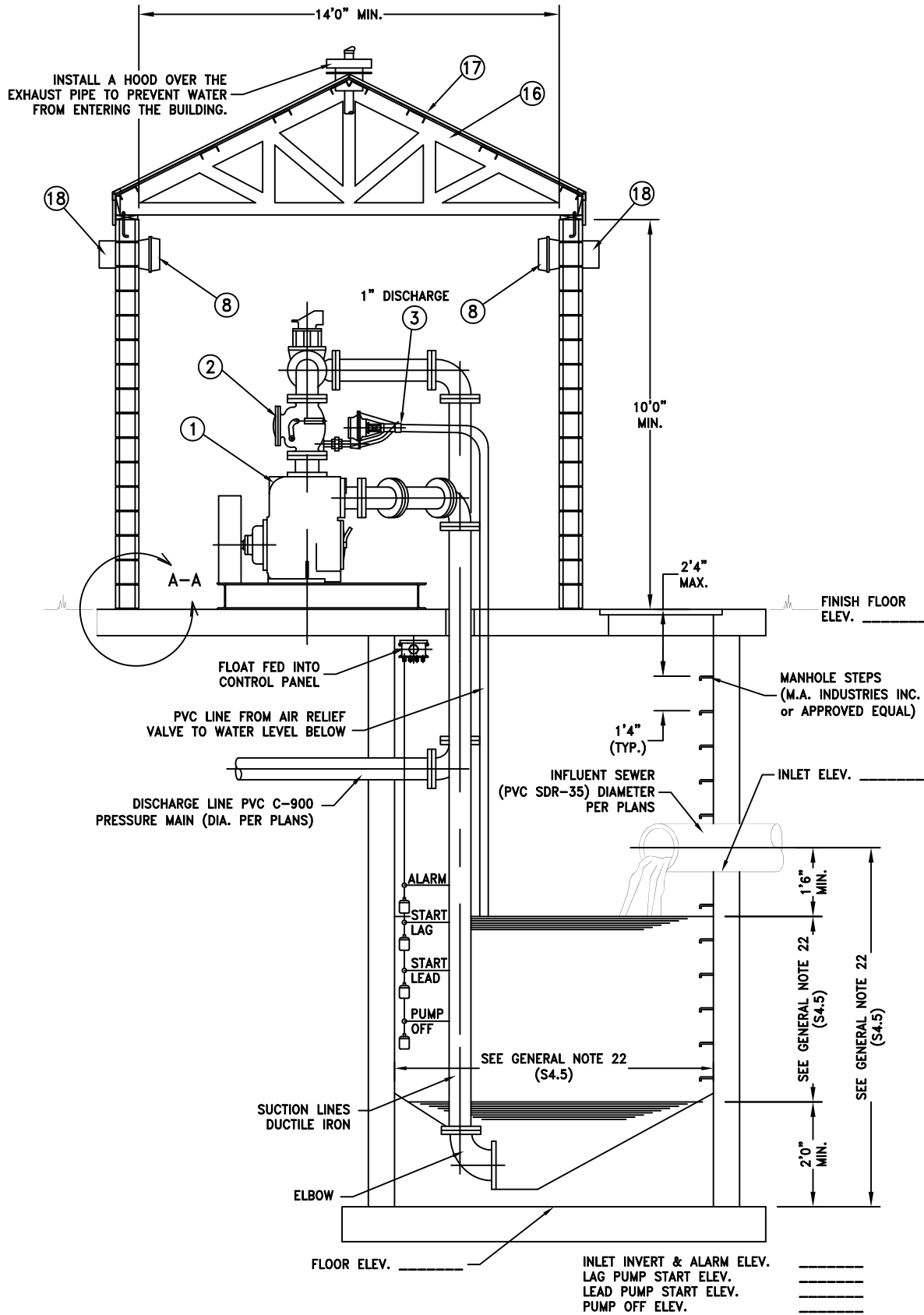

NOTES:

1. SEE S5.0C; SHEET 3 FOR CONSTRUCTION NOTES.
2. SEE S5.0D; SHEET 4 FOR GENERAL NOTES.

PUMP SIDE ELEVATION

N.T.S.



ENOCH CITY
 900 E MIDVALLEY RD
 Enoch, UT 84721
 Tel. (435) 586-1119

**SELF PRIMING
 SEWER LIFT STATION**

SCALE:
 N.T.S.
 DATE:
 DEC. 2022

DETAIL No.:

S5.0B

SHEET:
 2 of 4

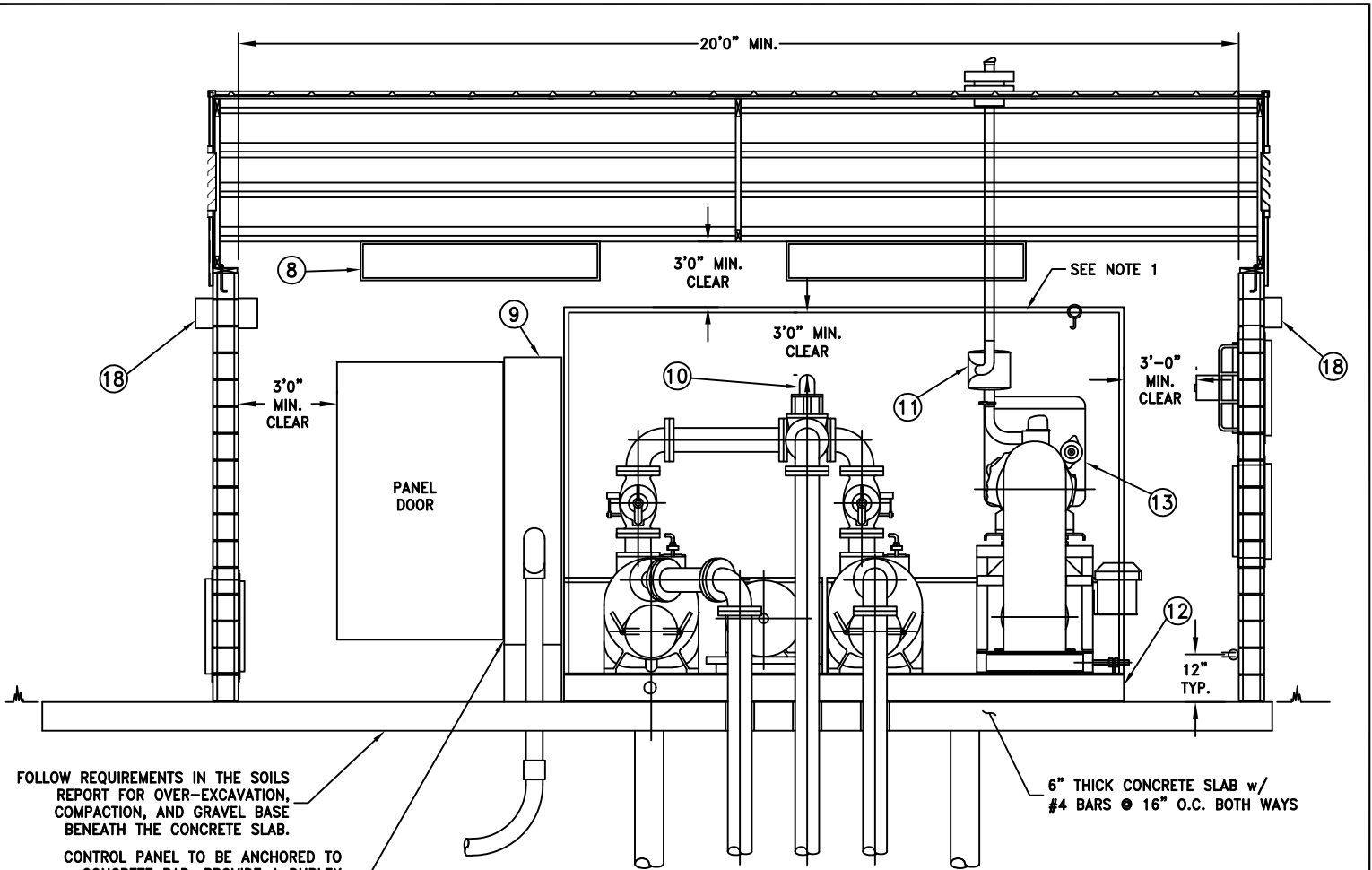

FOLLOW REQUIREMENTS IN THE SOILS REPORT FOR OVER-EXCAVATION, COMPACTION, AND GRAVEL BASE BENEATH THE CONCRETE SLAB.

CONTROL PANEL TO BE ANCHORED TO CONCRETE PAD. PROVIDE A DUPLEX OUTLET INSIDE THE CONTROL PANEL. SCADA EQUIPMENT TO BE PLUGGED IN INSIDE THE CONTROL PANEL CABINET.

6" THICK CONCRETE SLAB w/ #4 BARS @ 16" O.C. BOTH WAYS

PUMP FRONT ELEVATION
N.T.S.

NOTES:

1. LIFT BEAM FRAME w/ 2 TON TROLLEY HOIST MOUNTED TO THE SKIDS. LIFT BEAM SIZE TO BE DETERMINED BY THE ENGINEER. LIFT BEAM MUST BE TALL ENOUGH TO BE ABLE TO LIFT THE PUMPS UP AND OVER THE OTHER EQUIPMENT. LIFT BEAM FRAME TO BE SQUARE STRUCTURAL TUBING WITH MINIMUM 1/2" WALL THICKNESS (ASTM A500, GRADE B, FY = 46 KSI)
2. SEE S5.0D; SHEET 4 FOR GENERAL NOTES.

CONSTRUCTION NOTES

ITEM	DESCRIPTION	MATERIAL & SIZE
①	PUMP	CAST IRON T4A-B
②	DISCHARGE CHECK VALVE	CAST IRON
③	AIR RELEASE VALVE	CAST IRON
④	INTAKE VENT ASSY	ALUMINUM (4 SHUTTERS)
⑤	STATION ENCLOSURE	MASONRY BLOCK
⑥	MOTOR	CAST IRON
⑦	EXHAUST FAN ASSY	1600 CFM
⑧	FLUORESCENT LIGHT FIXTURE	80 WATT FIXTURE
⑨	CONTROL PANEL	STEEL
⑩	DISCHARGE PLUG VALVE	CAST IRON 3-WAY
⑪	EXHAUST SILENCER	STAINLESS STEEL
⑫	PUMP & MOTOR BASE ASSY	STEEL
⑬	ENGINE (NISSAN)	LIQUID COOLED
⑭	EXHAUST VENT ASSY	ALUMINUM (4 SHUTTERS)
⑮	BELT GUARD ASSY	STEEL
⑯	ROOF TRUSSES	STEEL
⑰	METAL INSULATED ROOF w/ FLASHING	STEEL
⑱	HPS LIGHT FIXTURE	175 WATT

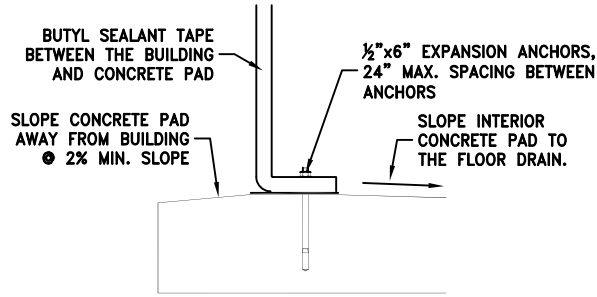

SECTION A-A
N.T.S.



ENOCH CITY
900 E MIDVALLEY RD
Enoch, UT 84721
Tel. (435) 586-1119

**SELF PRIMING
SEWER LIFT STATION**

SCALE:
N.T.S.
DATE:
DEC. 2022

DETAIL No.:

S5.0C

SHEET:
3 of 4

GENERAL NOTES:

1. NEED 3 PHASE POWER. 480-VOLT w/ CONNECTION FOR AUXILIARY GENERATOR.
2. BETWEEN PUMP SKIDS AND BUILDING FLOOR, VIBRATION ISOLATION PADS SHALL BE INSTALLED. SKIDS SHALL BE ANCHORED TO CONCRETE FLOOR AND VIBRATION ISOLATION PADS SHALL BE INSTALLED IN SMALL ENOUGH PIECES TO FIT UNDER RAILS.
3. THE PUMP STATION PHONE SYSTEM SHALL BE TIED TO THE ENOCH CITY SCADA SYSTEM USING AN AUTO-DIALER PER ENOCH CITY REQUIREMENTS. PROVIDE SUBMITTALS ON ALL AUTO-DIALER EQUIPMENT TO BE USED. THE SCADA SYSTEM MUST INCLUDE AN INTRUSION ALARM ON THE WET-WELL MANHOLE LID AND ON THE DOORS INTO THE LIFT STATION BUILDING, BUILDING TEMPERATURE SENSOR, HIGH LEVEL ALARM, MOTOR RUN, MOTOR FAIL ALARM, AND WET WELL LEVEL.
4. ALL CONDUITS AND UTILITIES COMING INTO THE BUILDING MUST COME IN THROUGH THE CONCRETE FLOOR SLAB. NO CONDUITS OR UTILITIES MAY ENTER THE BUILDING THROUGH THE WALLS. A SPARE 2" CONDUIT MUST BE STUBBED INTO THE BUILDING THROUGH THE FLOOR SLAB FOR FUTURE USE.
5. THE WET-WELL MUST BE LOCATED FACING THE STREET OR ACCESS ROAD SO THAT IT CAN BE EASILY ACCESSED BY THE CITY'S SEWER CLEANING TRUCK.
6. THE SOIL UNDERNEATH ALL CONCRETE SLABS MUST BE OVER EXCAVATED AND RE-COMPACTED PER THE RECOMMENDATIONS GIVEN IN THE SOILS REPORT.
7. THE CONCRETE SLAB MUST BE DOWELED INTO THE WET-WELL WITH #4 REBAR @ 16" O.C. TO PREVENT DIFFERENTIAL SETTLEMENT OF THE SLABS.
8. CULINARY WATER SERVICE MUST BE PROVIDED TO THE LIFT STATION SITE. INSTALL A FROST PROOF YARD HYDRANT ON THE SITE WITH 3 FEET BURY DEPTH. (SIMMONS BRAND) RUN CULINARY WATER INTO THE LIFT STATION BUILDING TO THE DEEP SINK. REFER TO THE LIFT STATION SITE PLAN STANDARD DETAIL S7.0.
9. SLOPE THE ENTIRE SITE AWAY FROM THE LIFT STATION BUILDING AT A MINIMUM 2% SLOPE TO PREVENT WATER FROM PONDING ON THE SITE.
10. MINIMUM LIFT STATION AREA IS 60' x 60', FENCED PER UDOT DETAIL NO. FG-6 w/ A 16' WIDE DOUBLE SWING GATE. REFER TO THE LIFT STATION SITE PLAN STANDARD DETAIL S6.0.
11. SEAL ALL OPENINGS THRU CONCRETE PAD INTO STATION ENCLOSURE GAS TIGHT.
12. A GAS TIGHT FLOOR DRAIN IS REQUIRED IN THE BUILDING. SLOPE THE CONCRETE FLOOR TO THE FLOOR DRAIN. DRAIN INTO THE WET-WELL.
13. THE FOLLOWING UTILITIES MUST BE RUN TO THE LIFT STATION SITE. THERE ARE NO EXCEPTIONS TO THIS REQUIREMENT. ALL OF THESE UTILITIES MUST BE BROUGHT INTO THE LIFT STATION SITE. ALL METER AND PANEL LOCATIONS MUST BE REVIEWED AND APPROVED BY THE CITY ENGINEER PRIOR TO INSTALLATION:
NATURAL GAS
POWER
TELEPHONE/FIBER INTERNET (IF AVAILABLE)
CULINARY WATER
14. THE CONTROL PANEL MUST BE ANCHORED TO THE CONCRETE PAD.
15. PROVIDE A DUPLEX OUTLET INSIDE THE CONTROL PANEL. SCADA EQUIPMENT MUST BE PLUGGED IN INSIDE THE CONTROL PANEL.
16. THE BUILDING SHALL COME EQUIPPED WITH A 12-VOLT DC EMERGENCY LIGHTING SYSTEM THAT WILL PROVIDE 50 WATTS OF ILLUMINATION FOR 1-1/2 HOURS IN THE EVENT OF AN EMERGENCY.
17. A MASONRY BLOCK STRUCTURE w/ INSULATED AND STEEL FRAMED METAL ROOF IS REQUIRED. THE MINIMUM BUILDING DIMENSIONS ARE 14' WIDE x 20' LONG x 10' TALL. THERE MUST BE AT LEAST 3' OF CLEARANCE ALL AROUND. HEIGHT CLEARANCE MUST ALLOW FOR THE LIFTING BEAM TO BE TALL ENOUGH TO LIFT THE PUMP EQUIPMENT UP AND OVER THE OTHER EQUIPMENT.
18. THIS DETAIL DRAWING DOES NOT TAKE THE PLACE OF STAMPED ENGINEERING DRAWINGS FOR THE LIFT STATION. STRUCTURAL DRAWINGS MUST BE PROVIDED FOR THE MASONRY BUILDING THAT ARE STAMPED BY A LICENSED STRUCTURAL ENGINEER. SUBMITTALS, SHOP DRAWINGS, ENGINEERING CALCULATIONS, AND STAMPED CONSTRUCTION DRAWINGS MUST BE SUBMITTED TO THE CITY ENGINEER FOR ALL PROPOSED PUMP EQUIPMENT AND FOR THE BUILDING. THE DIMENSIONS SHOWN ON THIS DRAWING ARE PROVIDED TO SHOW THE MINIMUM CLEARANCES THAT MUST BE MET.
19. 120-VOLT ELECTRICAL OUTLETS MUST BE LOCATED A MINIMUM OF 12" ABOVE THE FLOOR.
20. SUBMITTALS ARE REQUIRED FOR ALL LIGHTS, FANS, HEATER, ELECTRICAL EQUIPMENT, PUMPS, AUTO-DIALERS, ETC. AN OWNER'S MANUAL MUST BE PROVIDED TO THE CITY FOR ALL EQUIPMENT IN THE LIFT STATION PRIOR TO COMPLETION OF THE PROJECT.
21. THE CONTROL PANEL SHALL BE EQUIPPED WITH AN DORSETT SCADA SYSTEM TO PROVIDE CONTACT WITH CITY PERSONNEL ON ALL ALARM POINTS.
22. WET-WELL. THE SIZE OF THE WET-WELL AND THE DISTANCE FROM THE INVERT OF THE INFLUENT LINE TO THE CONCRETE PAD SHOULD BE PROPERLY DESIGNED TO ALLOW AT LEAST TEN MINUTES LAPSED TIME BETWEEN SUCCESSIVE STARTS OF A PUMP TO PREVENT SHORT CYCLING OF ELECTRIC MOTORS AND CONTROL.



ENOCH CITY
900 E MIDVALLEY RD
Enoch, UT 84721
Tel. (435) 586-1119

SELF PRIMING
SEWER LIFT STATION

SCALE:
N.T.S.
DATE:
DEC. 2022

DETAIL No.:

S5.0D

SHEET:
4 of 4

CONSTRUCTION NOTES:

- ① NEW PVC SDR-35 GRAVITY SEWER LINE GOING INTO LIFT STATION. (LINE SIZE PER PLANS)
- ② NEW PVC C900 PRESSURE SEWER PUMPBACK LINE GOING FROM LIFT STATION. (LINE SIZE PER PLANS)
- ③ INSTALL 16' WIDE x 6' HIGH DOUBLE SWING GATE WITH (3) STRANDS OF BARBED WIRE PER UDOT STANDARD DRAWING FG-6.
- ④ INSTALL 6' TALL CHAIN LINK FENCE WITH (3) STRANDS OF BARBED WIRE ON ARMS PER UDOT STANDARD DRAWING FG-6.
- ⑤ INSTALL 3" MINUS DRAIN ROCK 6" THICK IN THE ENTIRE FENCED IN AREA.
- ⑥ INSTALL 1" WATER LINE INTO BUILDING FOR SELF-PRIMING LIFT STATION.
- ⑦ INSTALL NEW FROST FREE HYDRANT AND DRAIN ROCK INCLUDING 1" WATER LINE FROM METER BOX.
- ⑧ LIFT STATION ENVELOPE PER ENGINEERED CONSTRUCTION PLANS FOR ALL BUILDINGS, CONCRETE, UTILITY METERS, ELECTRICAL EQUIPMENT, WET-WELL, ETC.
- ⑨ 2% MIN. SLOPE FROM TOP OF SLAB DOWN TO SURROUNDING GRADE.

NOTES:

1. THIS DETAIL DRAWING DOES NOT TAKE THE PLACE OF STAMPED ENGINEERING DRAWINGS FOR THE LIFT STATION SITE PLAN. THE DIMENSIONS SHOWN ON THIS DRAWING ARE PROVIDED ONLY TO SHOW THE MINIMUM CLEARANCES THAT MUST BE MET.
2. THE FOLLOWING UTILITIES MUST BE INSTALLED TO THE LIFT STATION SITE:
 CULINARY WATER
 TELEPHONE/FIBER INTERNET (IF AVAILABLE)
 POWER
 GAS
3. AUTO-DIALER IS REQUIRED FOR REMOTE MONITORING OF THE LIFT STATION.

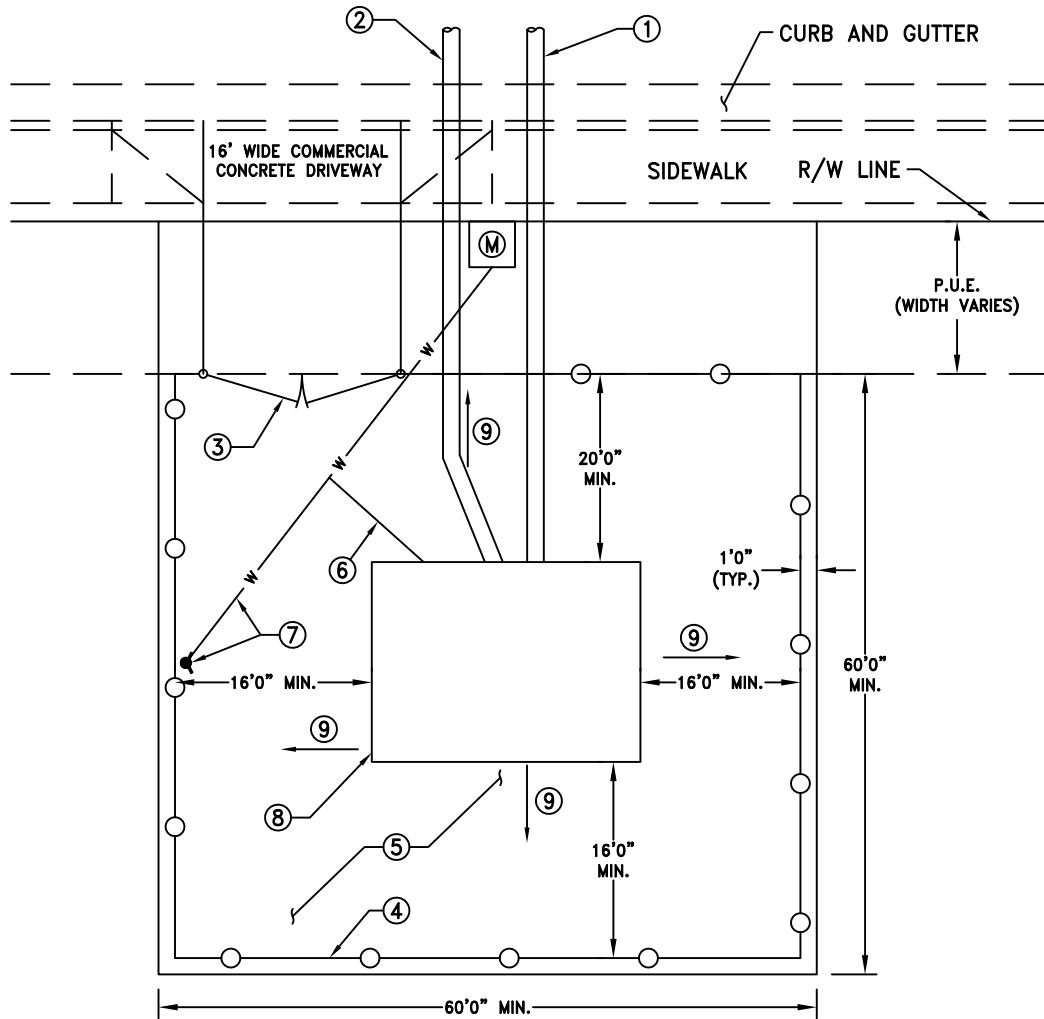

PLAN VIEW
N.T.S.



ENOCH CITY
 900 E MIDVALLEY RD
 Enoch, UT 84721
 Tel. (435) 586-1119

**SEWER LIFT STATION
 SITE PLAN**

SCALE:
 N.T.S.
 DATE:
 DEC. 2022

DETAIL No.:

S6.0

SHEET:
 1 of 1

CONSTRUCTION NOTES:

- ① 24" DIAMETER or SQUARE CONCRETE COLLAR 8" THICK. REINFORCEMENT #4 BAR 16" SQUARE w/ FIBERS (TYP.)
- ② TOP OF VALVE BOX AND CONCRETE COLLAR TO BE 1/4" BELOW FINAL STREET GRADE.
- ③ IF TOP OF VALVE NUT IS MORE THAN 4'0" DEEP THEN VALVE STEM EXTENSION IS REQUIRED PER DETAIL.
- ④ CLEAN OUT PIPE SIZE & MATERIAL SHALL BE THE SAME AS THE PRESSURE SEWER MAIN.
- ⑤ PIPE METAL CAP w/ LETTERS "SEWER"
- ⑥ 45° BEND REQ'D w/ RESTRAINT JOINTS (MEGALUG O.A.E.)
- ⑦ GATE VALVE (TYP.) w/ RESTRAINT JOINTS (MEGALUG O.A.E.)
- ⑧ TRENCH BACKFILL
- ⑨ CAST IRON SCREW TYPE VALVE BOX
- ⑩ PAVEMENT STRUCTURE AS SPECIFIED BY THE DESIGN AGENCY
- ⑪ TRACE-O-FLEX MARKER w/ TERMINAL POINTS BY CARSONITE - (ORANGE COLOR)
- ⑫ 12 GA. INSULATED COPPER LOCATE WIRE DUCT TAPED TO TOP OF PIPE AT 10'0" INTERVALS
- ⑬ PRESSURE SEWER MAIN.
- ⑭ SCH. 40 PVC PIPE (SIZE VARIES)
- ⑮ GATE VALVE w/ 2" VALVE WRENCH NUT
- ⑯ PVC CAP
- ⑰ TAPPING SADDLE PER SPECS.
- ⑱ INLINE ISOLATION VALVE (SEE NOTES)
- ⑲ CHECK VALVE BY CUSTOMER AT TIME OF CONNECTION.

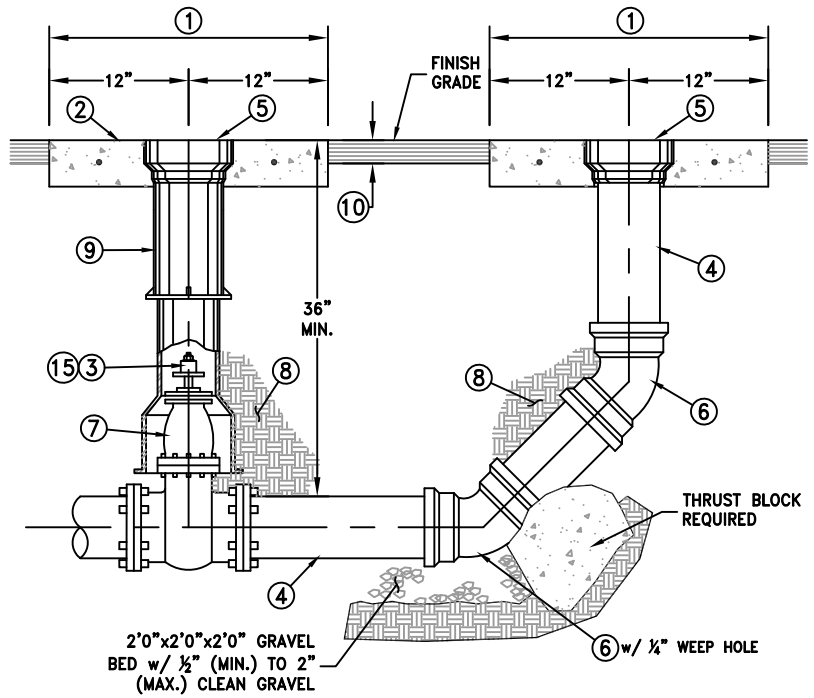

PRESSURE SEWER CLEAN-OUT DETAIL

N.T.S.

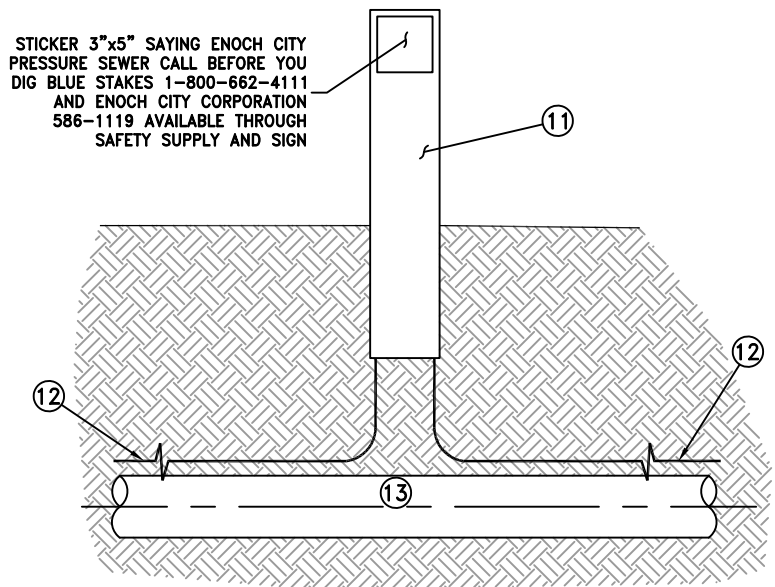

UNPAVED AREA LOCATOR POST DETAIL

N.T.S.

NOTES:

- 1. LOCATOR POSTS TO BE PLACED AT 1000'0" MAX. SPACING NEXT TO IN-LINE VALVES AND BENDS ON PRESSURE SEWER MAIN.
- 2. PRESSURE SEWER CLEAN-OUT TO BE PLACED AT 2000'0" MAX. SPACING NEXT TO END OF PIPES or IN-LINE VALVES.
- 3. IN-LINE VALVES TO BE PLACED EVERY 2000'0" MAX. ON PRESSURE SEWER LINES.
- 4. IN PAVED AREAS LOCATE WIRE SHALL BE TERMINATED IN THE VALVE CANS OF THE IN-LINE VALVES PER DETAIL.

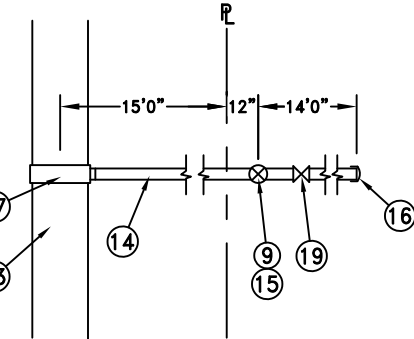

PRESSURE SEWER LATERAL

N.T.S.

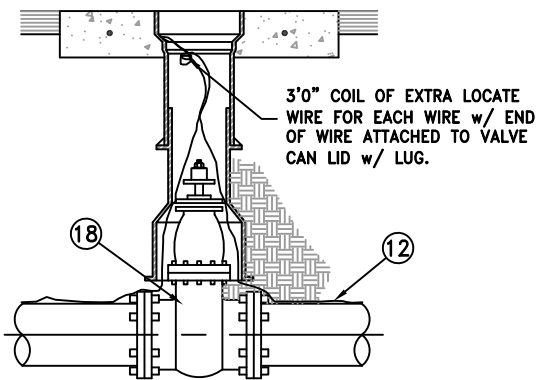

PAVED AREA LOCATE WIRE TERMINATION

N.T.S.



ENOCH CITY
900 E MIDVALLEY RD
Enoch, UT 84721
Tel. (435) 586-1119

**PRESSURE SEWER
CLEAN-OUT, LATERAL
& LOCATOR POST**

SCALE:
N.T.S.
DATE:
DEC. 2022

DETAIL No.:

S7.0

SHEET:
1 of 1

CONSTRUCTION NOTES:

- ① PETERSON SERIES 142 HAND TIGHTENING TEST PLUG TO BE REMOVED WHEN PUMP STATION IS ELIMINATED.
- ② FLOW CHANNEL
- ③ 4' DIA. SEWER MANHOLE
- ④ BURLAP SAND BAGS – TO BE REMOVED WHEN PUMP STATION IS ELIMINATED
- ⑤ FLOW CHANNEL TO PUMP STATION TO BE FILLED WITH GROUT WHEN PUMP STATION IS ELIMINATED.

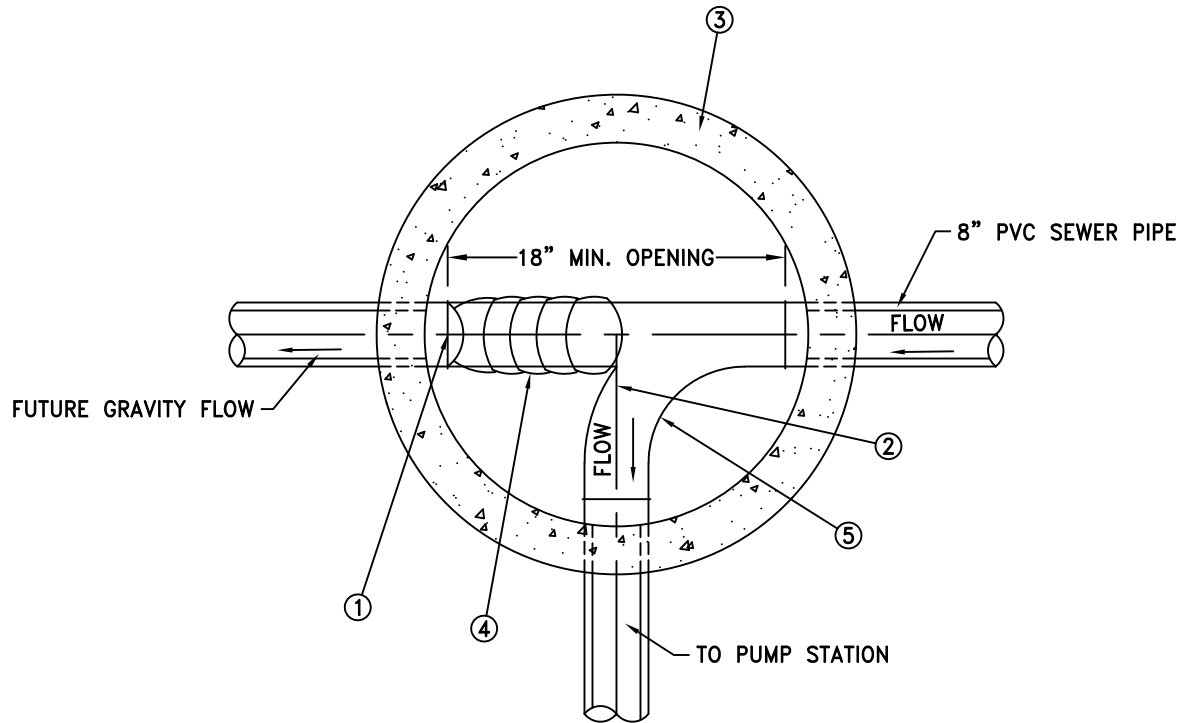

ENOCH CITY
900 E MIDVALLEY RD
Enoch, UT 84721
Tel. (435) 586-1119

**SEWER LIFT STATION
MANHOLE**

SCALE:
N.T.S.
DATE:
DEC. 2022

DETAIL No.:

S8.0

SHEET:
1 of 1

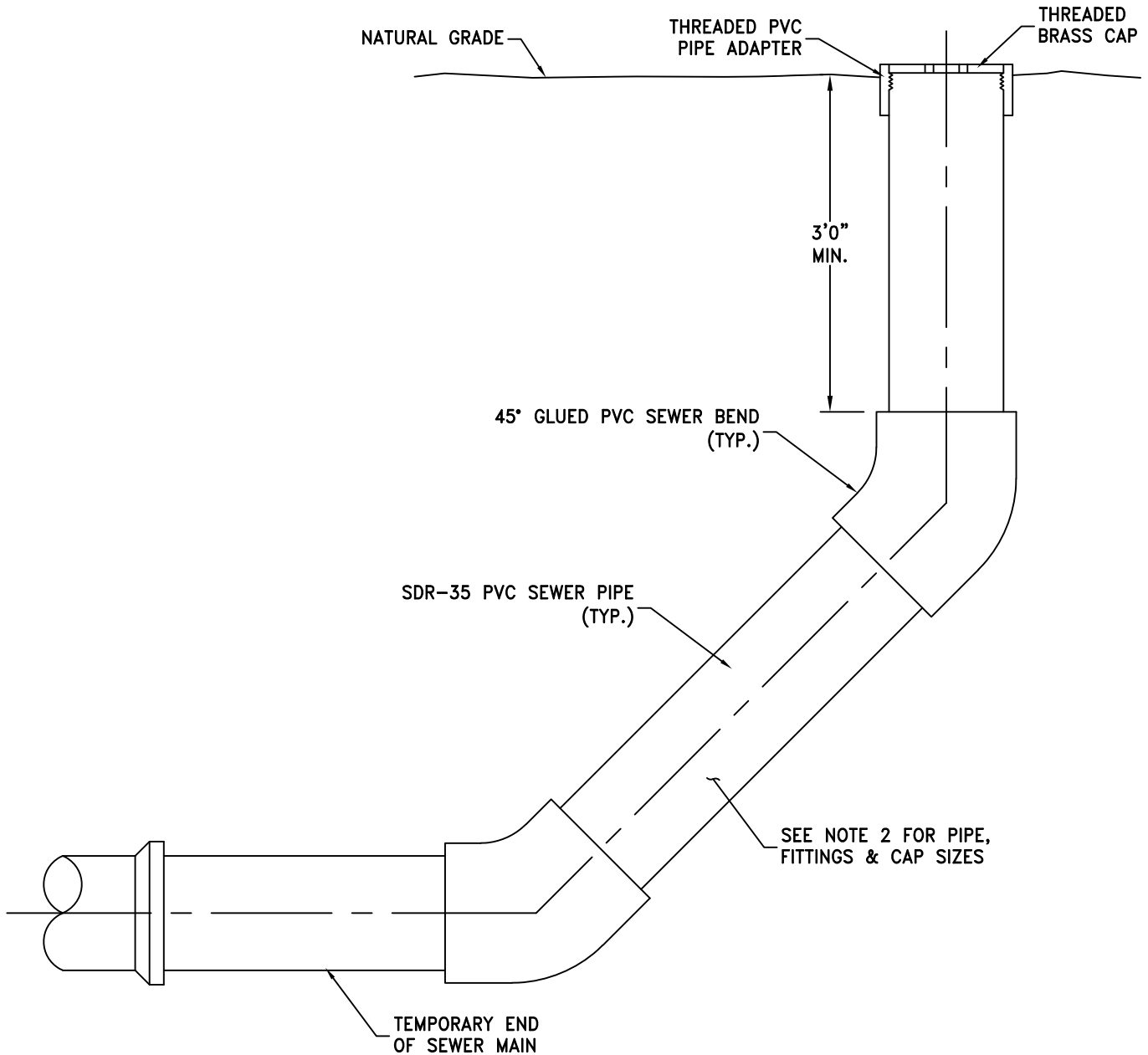

TEMPORARY SEWER MAIN CLEAN-OUT DETAIL
 (UNPAVED AREA)
 N.T.S.

NOTES:

1. PERMANENT ENDS OF SEWER MAIN SHALL HAVE A SEWER MANHOLE PER DETAIL S2.0.
2. THE DIAMETER OF ALL PIPE, FITTINGS AND CAP OF THE TEMPORARY SEWER CLEAN-OUT SHALL BE THE SAME DIAMETER OF THE SEWER MAIN LINE.



ENOCH CITY
 900 E MIDVALLEY RD
 Enoch, UT 84721
 Tel. (435) 586-1119

**TEMPORARY SEWER
 MAIN CLEAN-OUT
 (UNPAVED AREA)**

SCALE:
 N.T.S.
 DATE:
 DEC. 2022

DETAIL No.:

S9.1

SHEET:
 1 of 1

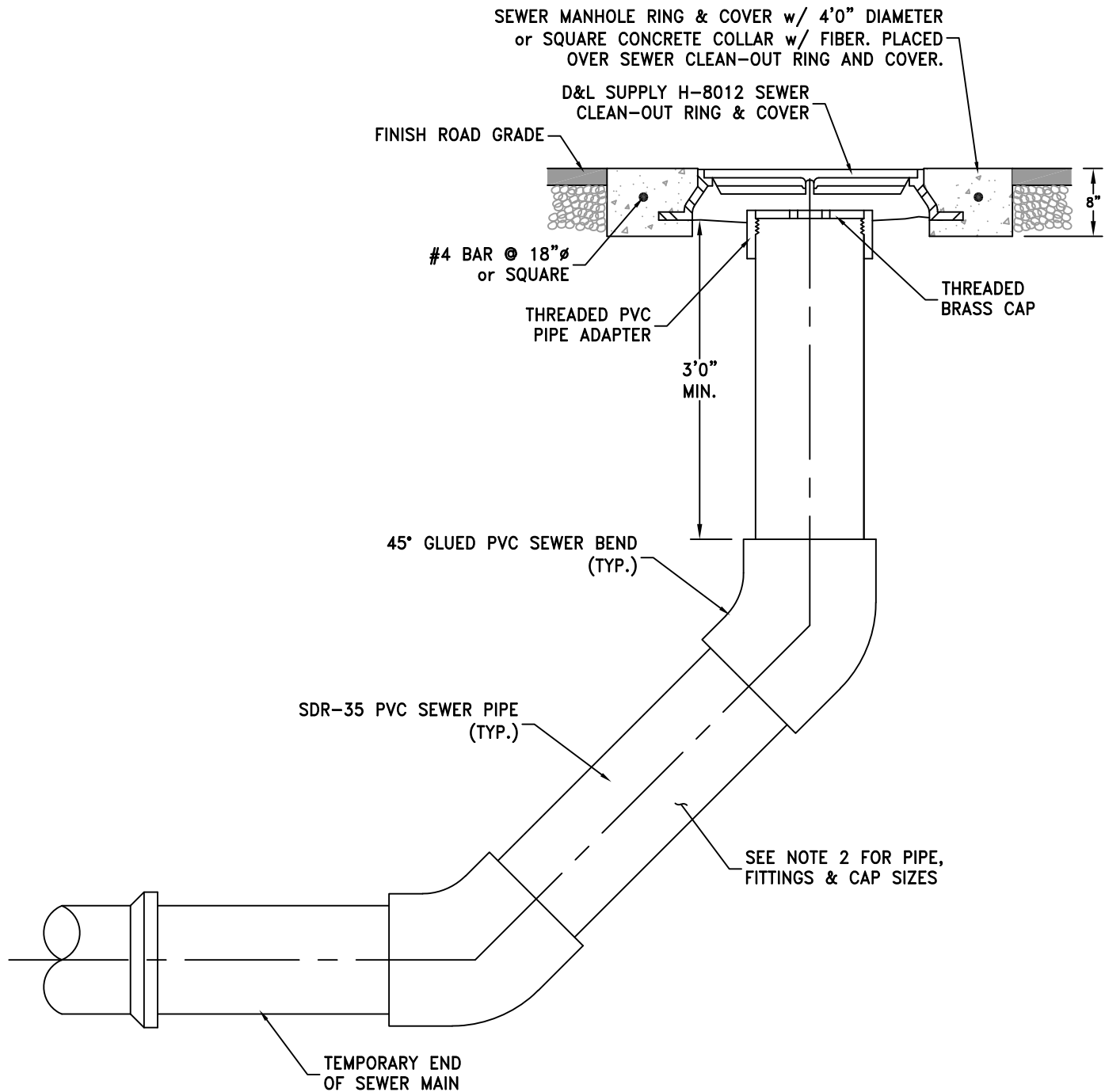

TEMPORARY SEWER MAIN CLEAN-OUT DETAIL
(PAVED AREA)
N.T.S.

NOTES:

1. PERMANENT ENDS OF SEWER MAIN SHALL HAVE A SEWER MANHOLE PER DETAIL S2.0.
2. THE DIAMETER OF ALL PIPE, FITTINGS AND CAP OF THE TEMPORARY SEWER CLEAN-OUT SHALL BE THE SAME DIAMETER OF THE SEWER MAIN LINE.



ENOCH CITY
900 E MIDVALLEY RD
Enoch, UT 84721
Tel. (435) 586-1119

**TEMPORARY SEWER
MAIN CLEAN-OUT
(PAVED AREA)**

SCALE:
N.T.S.
DATE:
DEC. 2022

DETAIL No.:

S9.2

SHEET:
1 of 1

NOTES:

1. SANITARY TANK HATCH SHALL BE OPW 269 4" DIA. SELF-CLOSING, FOOT OPERATIONAL and/or SPRING/WEIGHTED COVER or APPROVED EQUAL. OPENING SHALL BE FLUSH WITH BASE/GRADE OF CONTAINED AREA.
2. IF WATER SERVICE IS TO BE PROVIDED ALL STEPS SHALL BE TAKEN TO FOLLOW STATE & FEDERAL LAWS FOR PROPER USE OF CULINARY WATER AROUND OPEN WASTE RV DUMP STATIONS.
3. THE CITY RESERVES THE RIGHT TO VERIFY, APPROVE, or DENY THE LOCATION OF ANY PROPOSED RV DUMP STATION DUE TO PROXIMITY TO A STORM WATER CATCH BASIN.
4. CURB AND GUTTER ALSO PERMITTED.

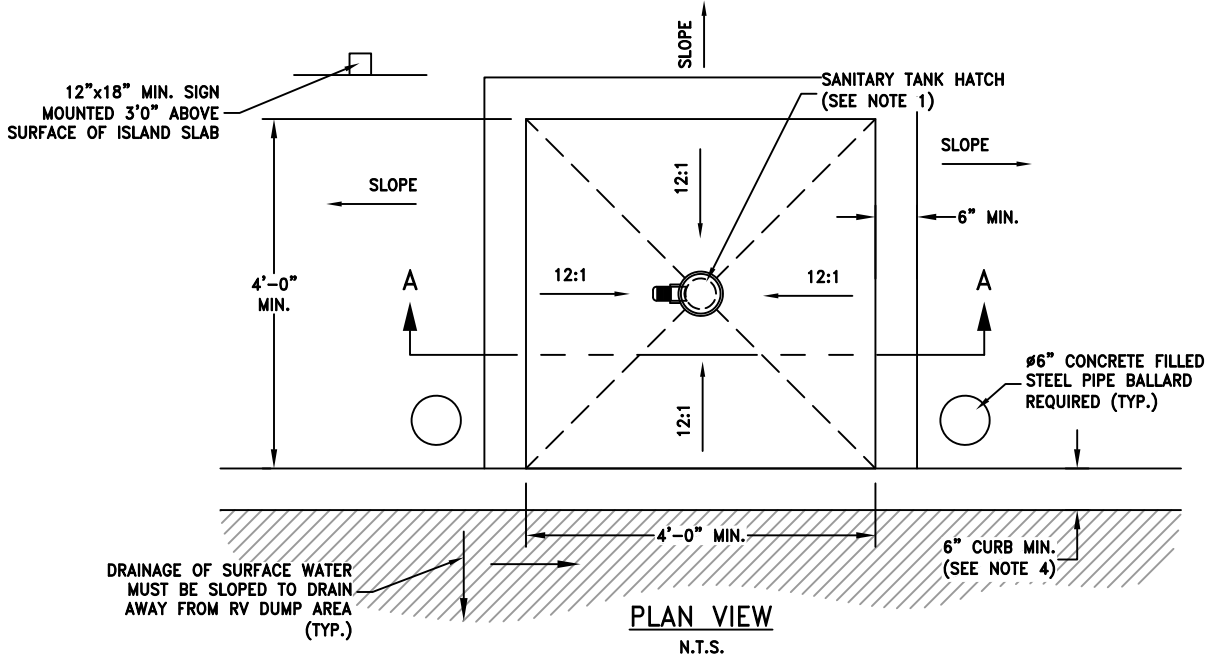
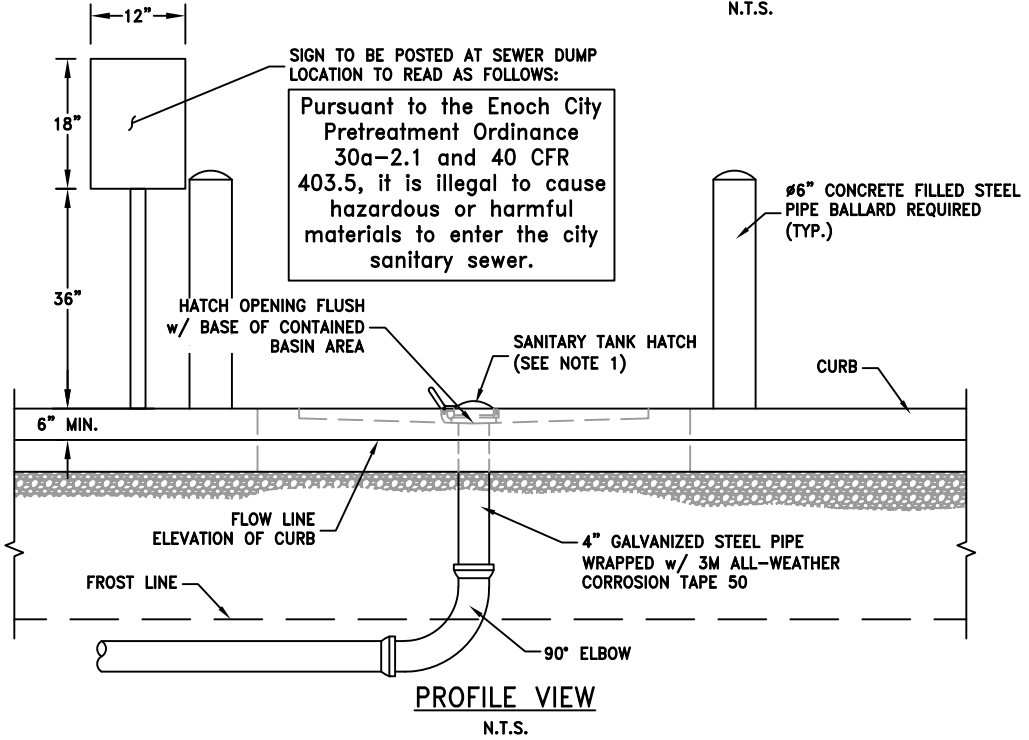
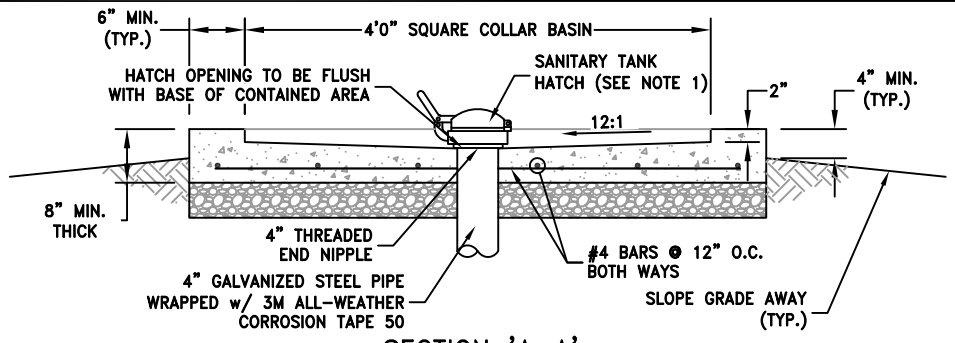

ENOCH CITY
900 E MIDVALLEY RD
Enoch, UT 84721
Tel. (435) 586-1119

RV DUMP STATION

SCALE:
N.T.S.
DATE:
DEC. 2022

DETAIL No.:
S10.0
SHEET:
1 of 1

HEIGHT	RISER CODE	WEIGHT
1'0"	CB231R	930#
2'0"	CB232R	1860#
3'0"	CB233R	2790#

NOTES:

1. WHEN REQUIRED MULTIPLE UNIT ASSEMBLIES SHALL BE INSTALLED WITH A SINGLE CATCH BASIN ENLARGED ACCORDINGLY.
2. CAST IN PLACE BOXES MAY BE USED WHEN APPROVED BY THE CITY ENGINEER.
3. TOP OF INLET BOX GRATE TO BE RECESSED 2" LOWER THAN FLOW LINE OF GUTTER AS SHOWN IN DETAIL BELOW.
4. CONCRETE TROUGH FLOW LINE REQUIRED PER DETAIL D5.0 ON IN-LINE/FLOW THRU BOXES.
5. BOX & GRATE GRADE TO MATCH GRADE OF CURB AND GUTTER GRADE.
6. GRATE FRAME TO BE SET DIRECTLY ON TOP OF BOX OR TOP OF PRECAST CONCRETE GRADE RING AT THE ELEVATION 2" LOWER THAN FLOW LINE OF THE CURB AND GUTTER PER THE INLET RECESS DETAIL BELOW.

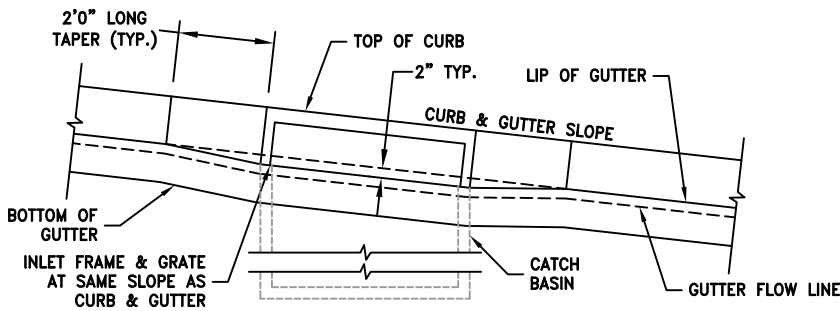
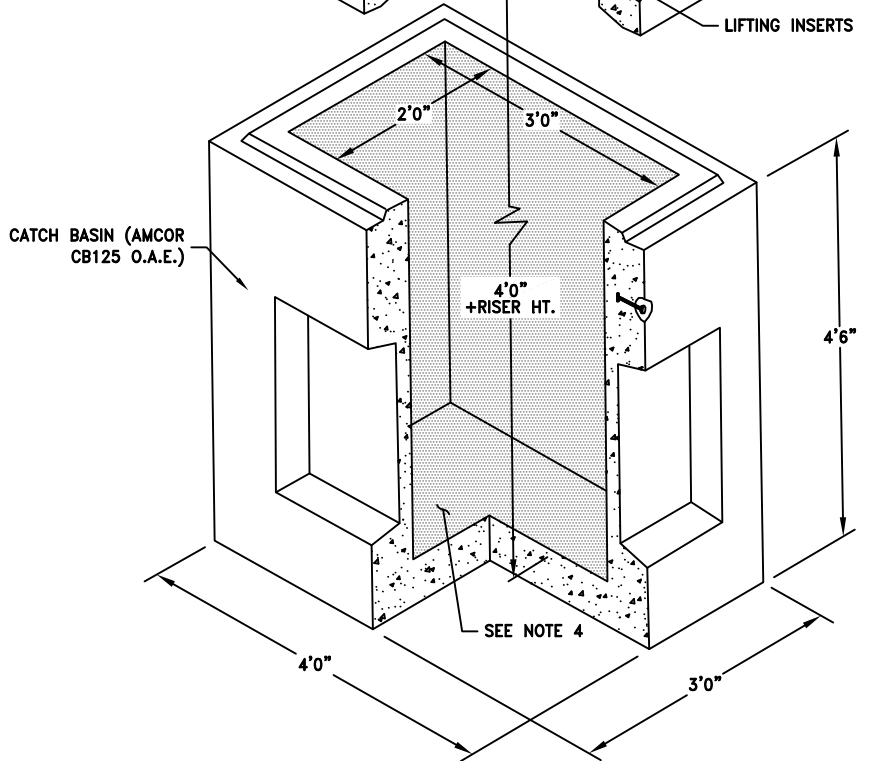
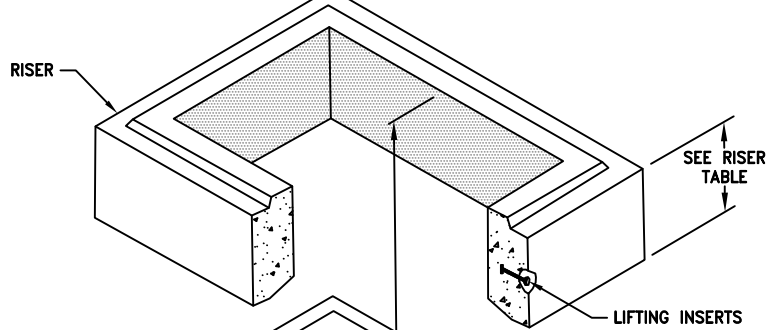
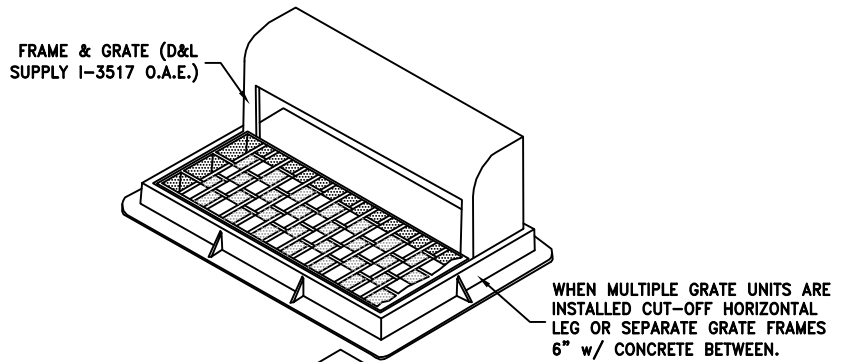

INLET RECESS DETAIL
N.T.S.



ENOCH CITY
900 E MIDVALLEY RD
Enoch, UT 84721
Tel. (435) 586-1119

CURB INLET BOX

SCALE:
N.T.S.
DATE:
DEC. 2022

DETAIL No.:

D1.0

SHEET:
1 of 1

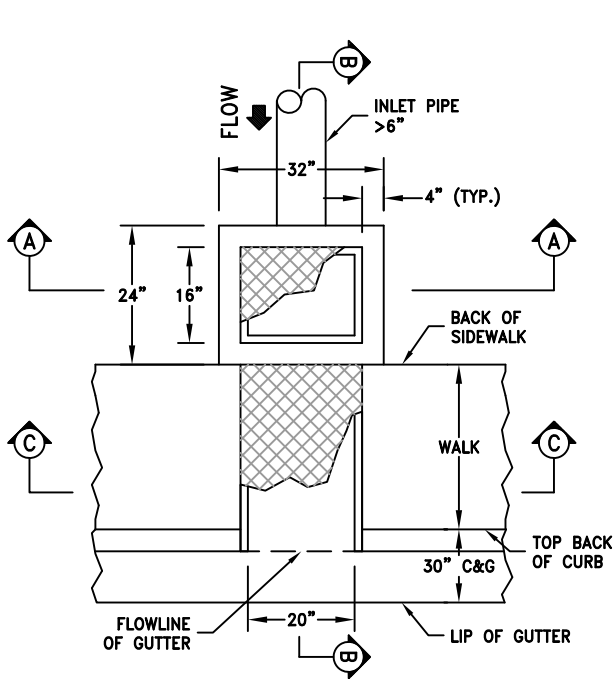

PLAN VIEW
N.T.S.

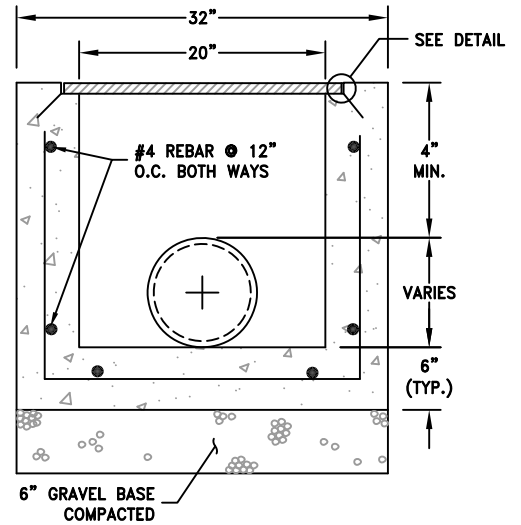

SECTION A-A
N.T.S.

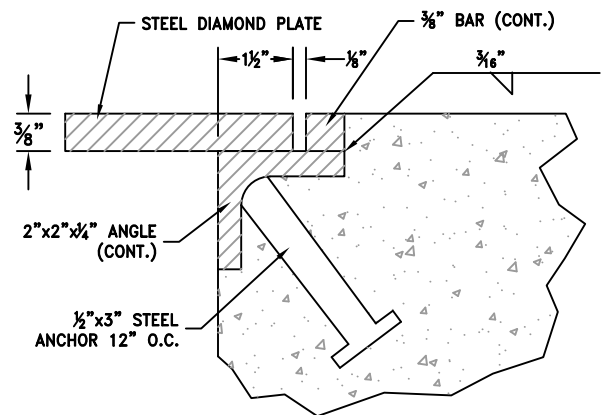

ANCHOR DETAIL
N.T.S.

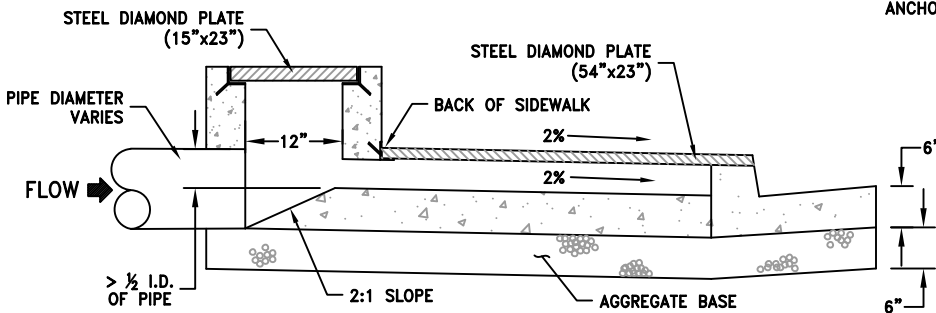

SECTION B-B
N.T.S.

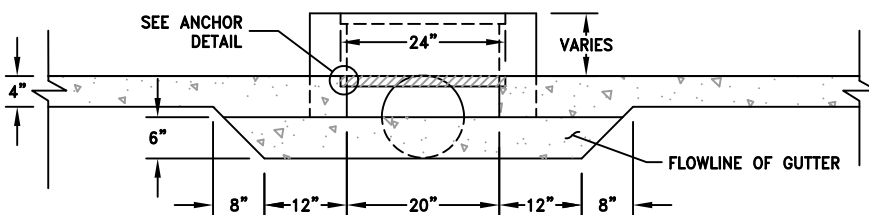

SECTION C-C
N.T.S.

NOTES:

1. ALL EXPOSED METAL PARTS SHALL BE A-36 HOT DIPPED GALVANIZED or PAINTED AND ALL GALVANIZING DAMAGED BY FABRICATION or INSTALLATION SHALL RECEIVE TWO COATS OF GALVANIZED PAINT (PAINT TO BE RUSTOLEUM GALVANIZING COMPOUND SPRAY or EQUAL).

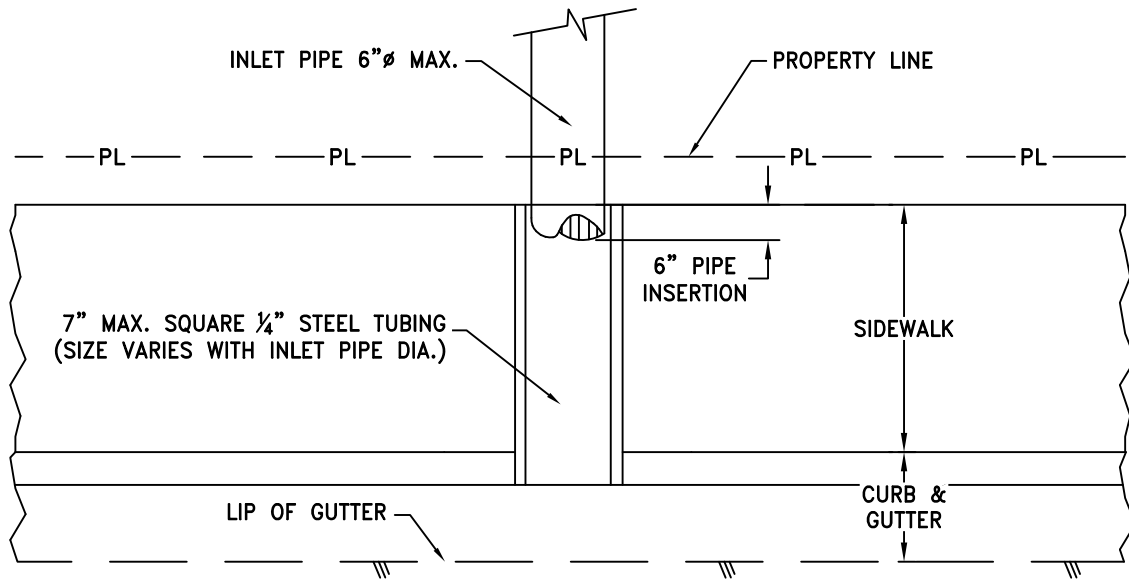

PLAN VIEW
N.T.S.

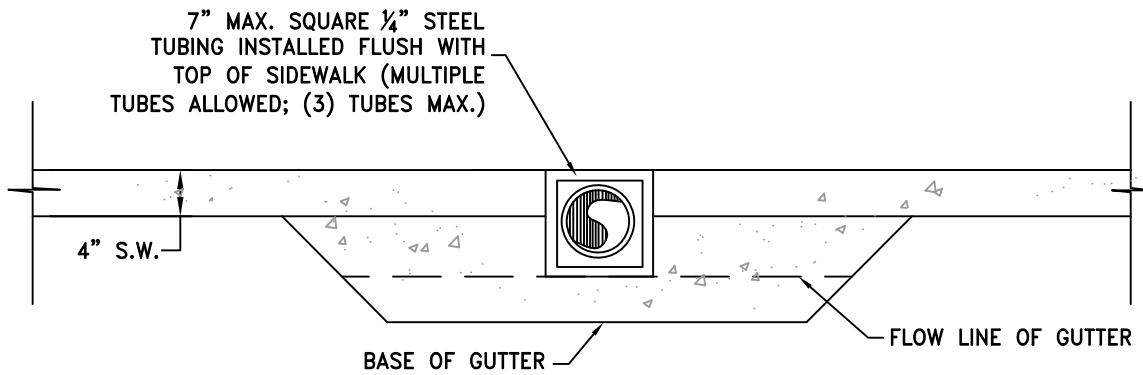

SECTION
N.T.S.

NOTES:

1. ALL EXPOSED METAL PARTS SHALL BE A-36 HOT DIPPED GALVANIZED or PAINTED AND ALL GALVANIZING DAMAGED BY FABRICATION or INSTALLATION SHALL RECEIVE TWO COATS OF GALVANIZED PAINT (PAINT TO BE RUSTOLEUM GALVANIZING COMPOUND SPRAY or EQUAL).



ENOCH CITY
900 E MIDVALLEY RD
Enoch, UT 84721
Tel. (435) 586-1119

SMALL CURB OUTLET BOX

SCALE:
N.T.S.
DATE:
DEC. 2022

DETAIL No.:

D3.0

SHEET:
1 of 1

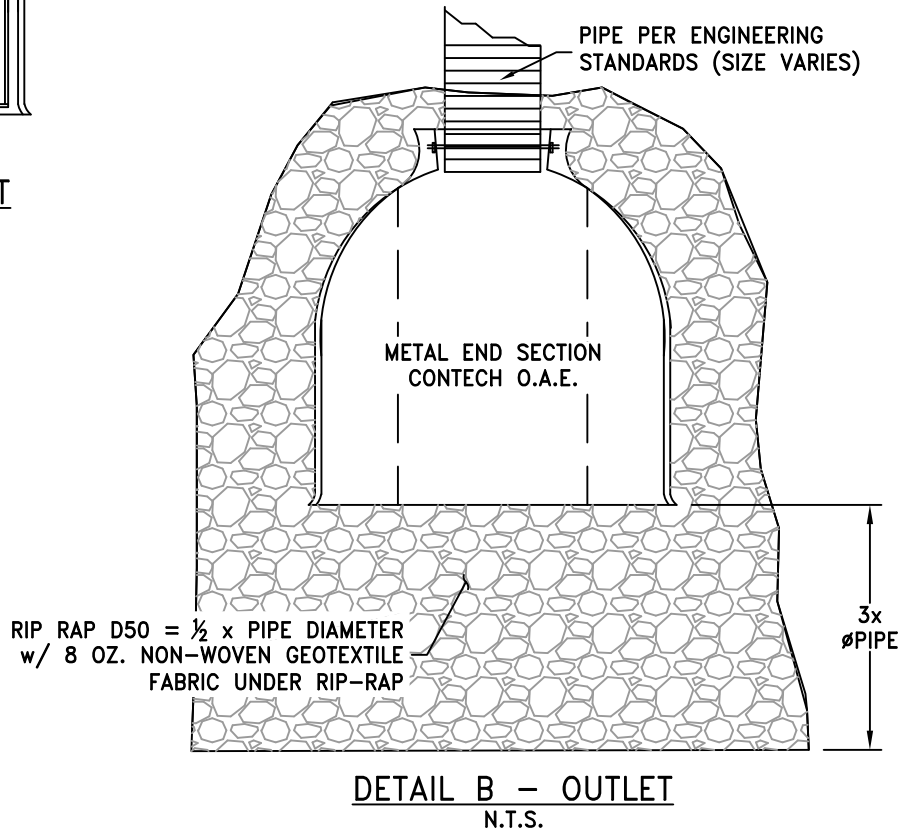
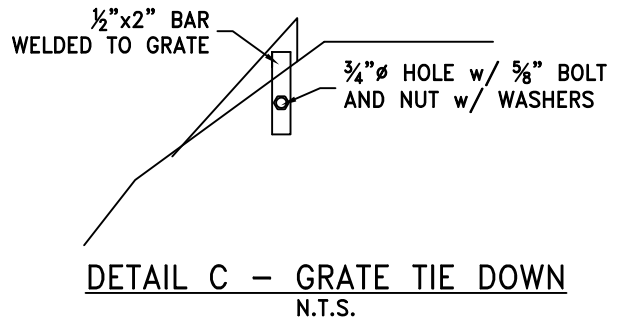
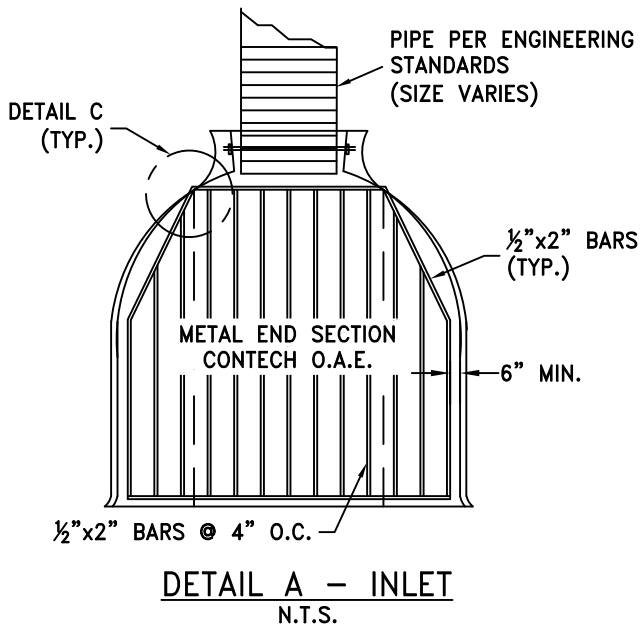
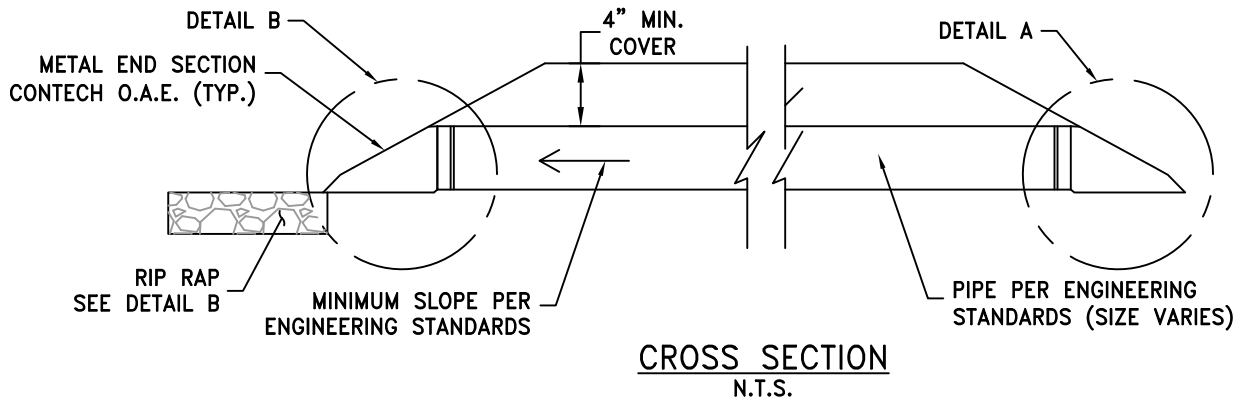

ENOCH CITY
900 E MIDVALLEY RD
Enoch, UT 84721
Tel. (435) 586-1119

STORM DRAIN
CULVERT & END
SECTIONS

SCALE:
N.T.S.
DATE:
DEC. 2022

DETAIL No.:

D4.0

SHEET:
1 of 1

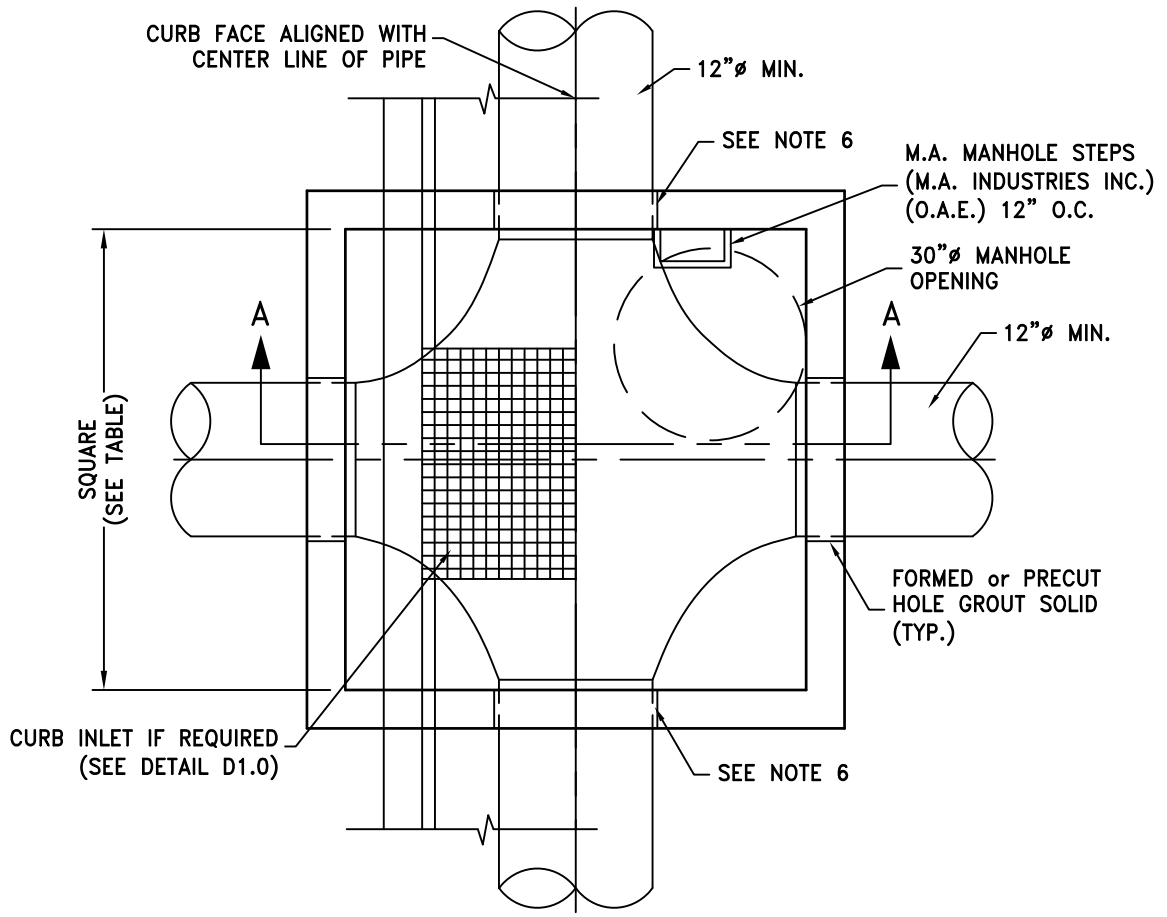

PLAN VIEW
N.T.S.

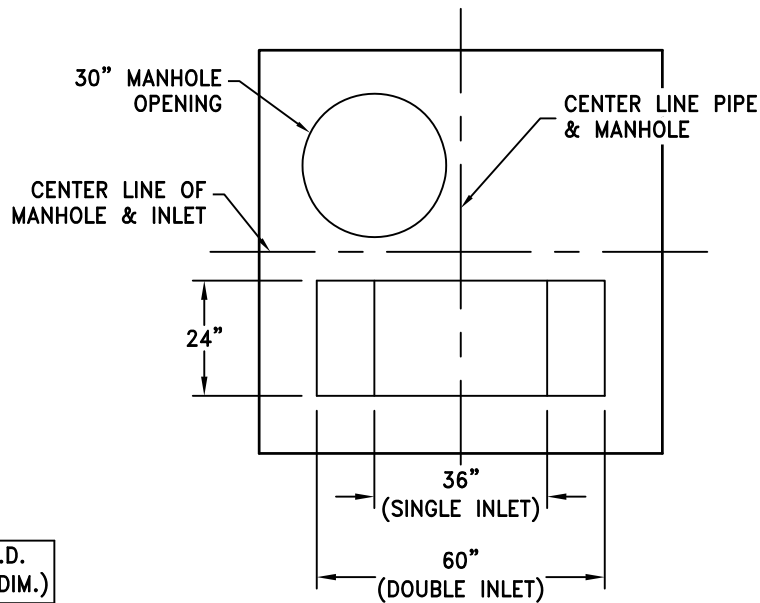

CURB INLET CUT-OUT DETAIL
N.T.S.

PIPE DIAMETER	MANHOLE I.D. (SQ. INSIDE DIM.)
12"-18"	48"
20"-36"	60"
42"-48"	72"
> 48"	84"

SEE NOTE 1



ENOCH CITY
900 E MIDVALLEY RD
Enoch, UT 84721
Tel. (435) 586-1119

**STORM DRAIN
MANHOLE**

SCALE:
N.T.S.
DATE:
DEC. 2022

DETAIL No.:

D5.0A

SHEET:
1 of 2

4'0" CONCRETE COLLAR w/ (4) #4 BARS w/ REINFORCING FIBERS, CONCRETE COLLAR THICKNESS 8" MINIMUM BUT THICK ENOUGH TO ENCASE GRADE RINGS. (SEE NOTE 2)

#5 REBAR @ 4" O.C. BOTH WAYS (SEE NOTE 3)

D&L MANHOLE RING AND GRATE NO. C-2670 (O.A.E.)

CONCRETE GRADE RINGS or 30" I.D. CORRUGATED POLYETHYLENE PIPE ENCASED IN CONCRETE COLLAR (12" MAX. HEIGHT)

12" MIN.

2'4" MAX.

SEAL ALL JOINTS w/ "RAM-NEK" (O.A.E.) ASPHALTIC SEALER

#5 REBAR @ 8" O.C. BOTH WAYS

6" MIN.

VARIES

1/2 PIPE Ø

6" MIN.

CONCRETE TROUGH SLOPED TO PIPE

#5 REBAR @ 8" O.C. BOTH WAYS (SEE NOTE 3)

UNDISTURBED EARTH or 12" OF 1" MAX. ROCK

NOTES:

1. CAN USE INLET BOX AS A MANHOLE FOR 12"-18" PIPE IF PLACED IN CURB PER DETAIL D1.0.
2. MANHOLES IN ROADWAYS REQUIRE A CONCRETE COLLAR. MANHOLES IN UNIMPROVED AREAS SHALL BE SET 6"-12" ABOVE FINISH GRADE. (NO CONCRETE COLLAR REQUIRED)
3. PRE-CAST MANHOLE TO HAVE H-20 LOAD RATING CERTIFICATION.
4. INSTALL NON-SHRINK GROUT BETWEEN ALL CONCRETE GRADE RINGS AND MANHOLE COVER RING.
5. MANHOLE LID, RING AND CONCRETE COLLAR TO BE CENTERED ON MANHOLE OPENING AND SET 1/4" BELOW TOP OF ASPHALT.
6. MANHOLE INLET PIPE INVERT TO BE 0.20 FEET HIGHER THAN OUT PIPE INVERT.



ENOCH CITY
900 E MIDVALLEY RD
Enoch, UT 84721
Tel. (435) 586-1119

STORM DRAIN
MANHOLE

SCALE:
N.T.S.
DATE:
DEC. 2022

DETAIL No.:

D5.0B

SHEET:
2 of 2

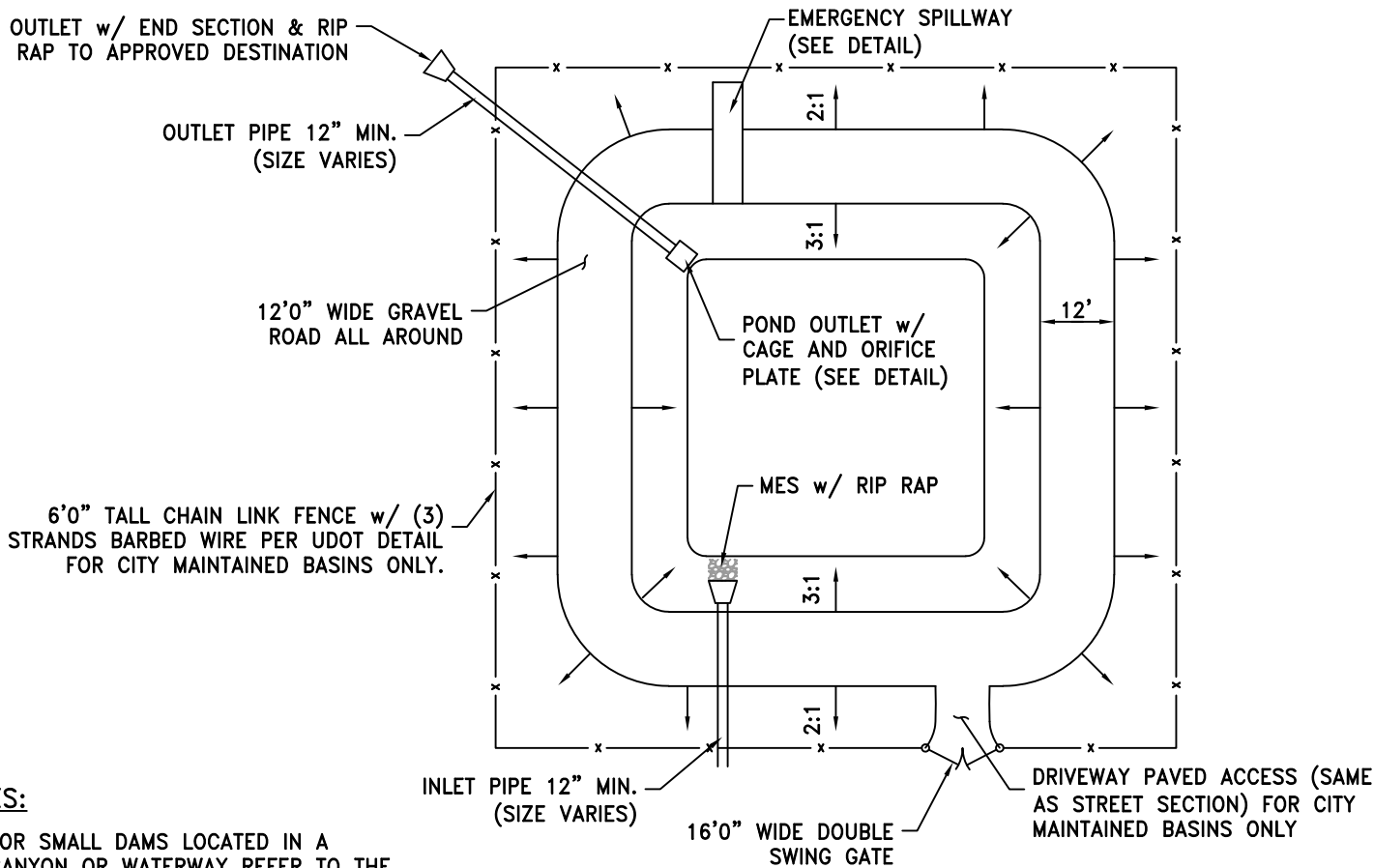

SITE PLAN
N.T.S.

NOTES:

1. FOR SMALL DAMS LOCATED IN A CANYON OR WATERWAY REFER TO THE DETAILS FROM STATE DAM SAFETY.
2. MINIMUM AMOUNT OF ACREAGE SERVED BY A DETENTION POND = 160 ACRES

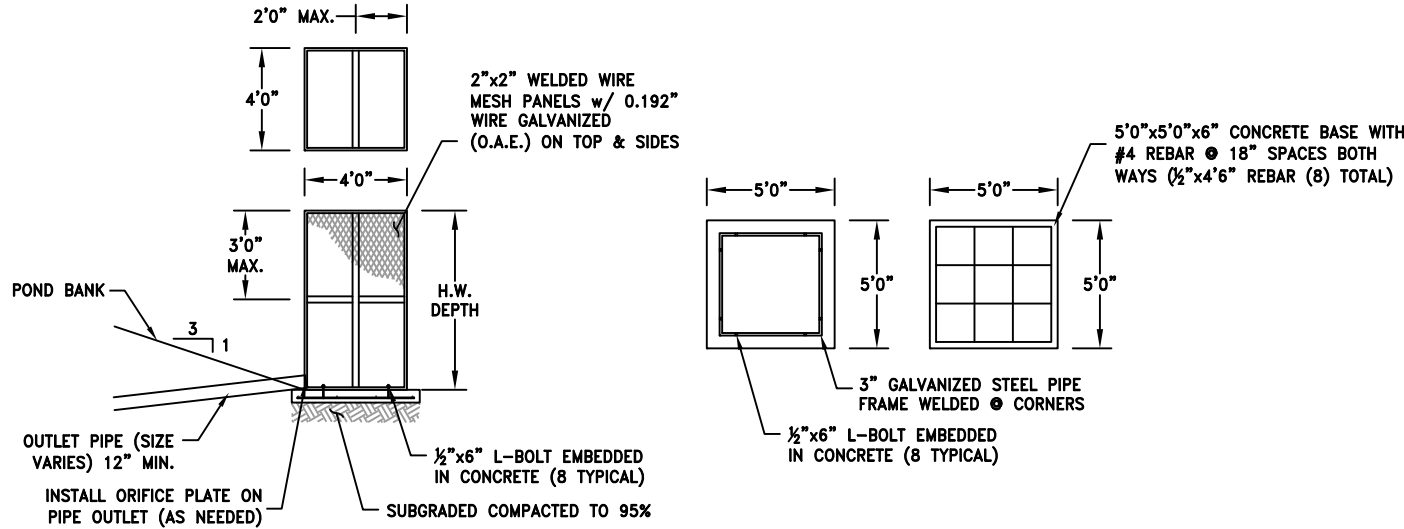

SCREEN POND OUTLET DETAIL
N.T.S.



ENOCH CITY
900 E MIDVALLEY RD
Enoch, UT 84721
Tel. (435) 586-1119

DETENTION BASIN

SCALE:
N.T.S.
DATE:
DEC. 2022

DETAIL No.:

D6.0A

SHEET:
1 of 2

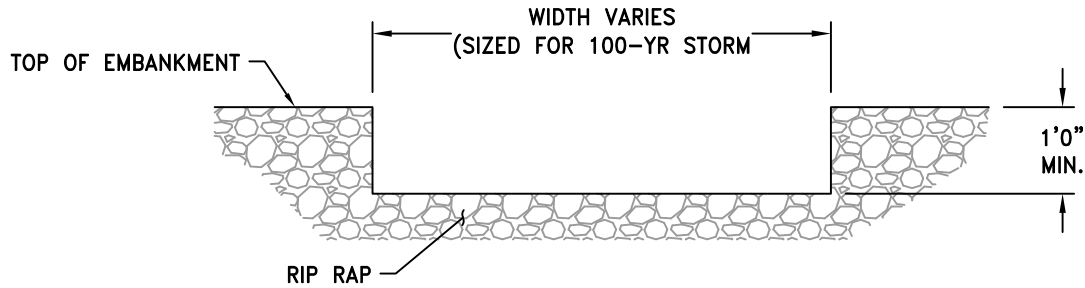

EMERGENCY SPILLWAY DETAIL
N.T.S.

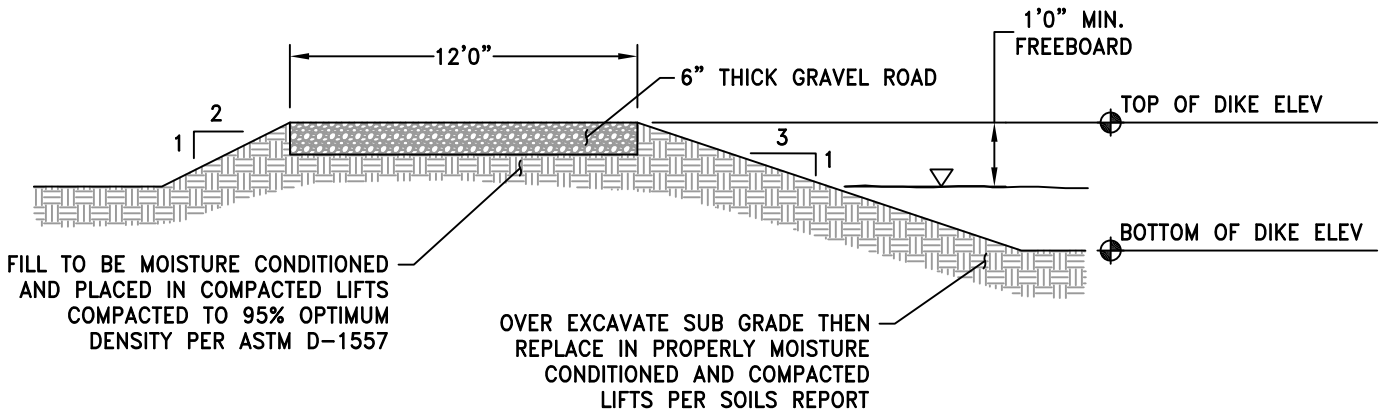

NOTES:

1. FILL SHALL BE PLACED IN LOOSE LIFT THICKNESS WHICH DOES NOT EXCEED THE CAPACITY OF THE EQUIPMENT BEING UTILIZED NOT TO EXCEED 8". MAXIMUM LIFT THICKNESS SHALL BE REDUCED TO 4" FOR HAND COMPACTION EQUIPMENT.

EMBANKMENT SECTION DETAIL
N.T.S.

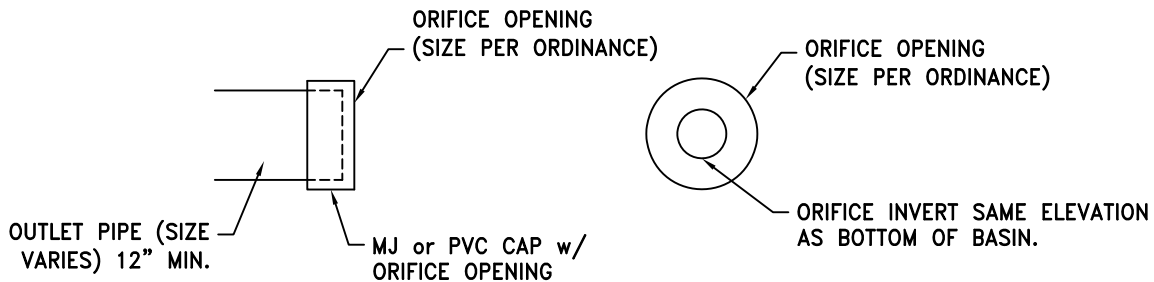

ORIFICE DETAIL
N.T.S.



ENOCH CITY
900 E MIDVALLEY RD
Enoch, UT 84721
Tel. (435) 586-1119

DETENTION BASIN

SCALE:
N.T.S.
DATE:
DEC. 2022

DETAIL No.:

D6.0B

SHEET:
2 of 2

NOTES:

1. ALL EXPOSED METAL PARTS SHALL BE A-36 GALVANIZED STEEL AND ALL GALVANIZING DAMAGED BY FABRICATION or INSTALLATION SHALL RECEIVE TWO COATS OF ALUMINUM PAINT (GALVONOX or EQUAL).
2. GRATING WITH $1\frac{3}{4}" \times \frac{3}{16}"$ BARS AND DIAMOND PLATE SHALL ONLY BE USED IN SIDEWALKS.

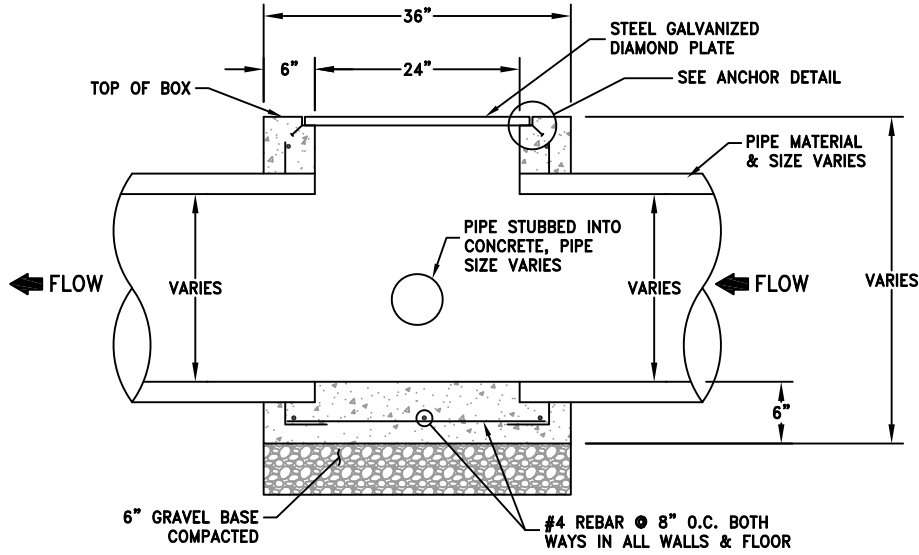

SECTION A-A
N.T.S.

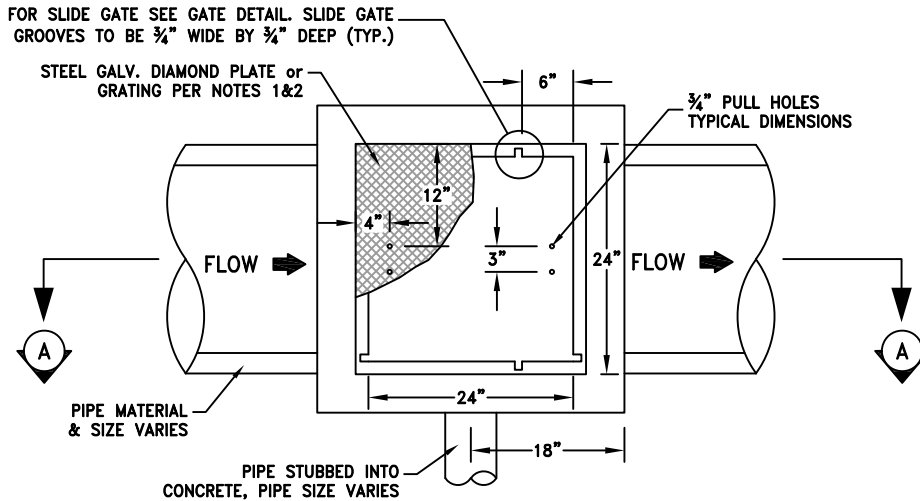

PLAN VIEW
N.T.S.

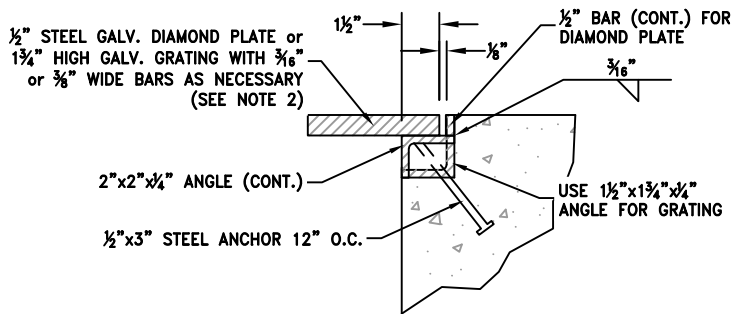

ANCHOR DETAIL
N.T.S.

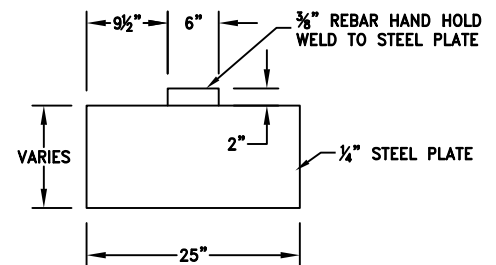

GATE DETAIL
N.T.S.



ENOCH CITY
900 E MIDVALLEY RD
Enoch, UT 84721
Tel. (435) 586-1119

IRRIGATION DIVERSION BOX

SCALE:
N.T.S.
DATE:
DEC. 2022

DETAIL No.:

D7.0

SHEET:
1 of 1

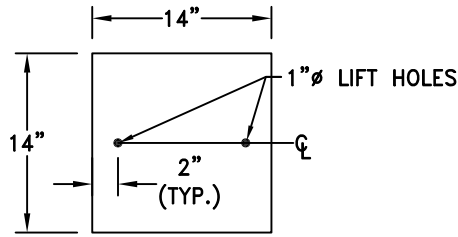

LID DETAIL
N.T.S.

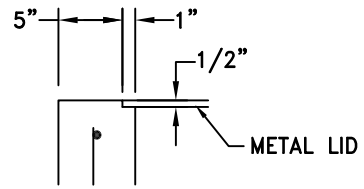

CONCRETE NOTCH
N.T.S.

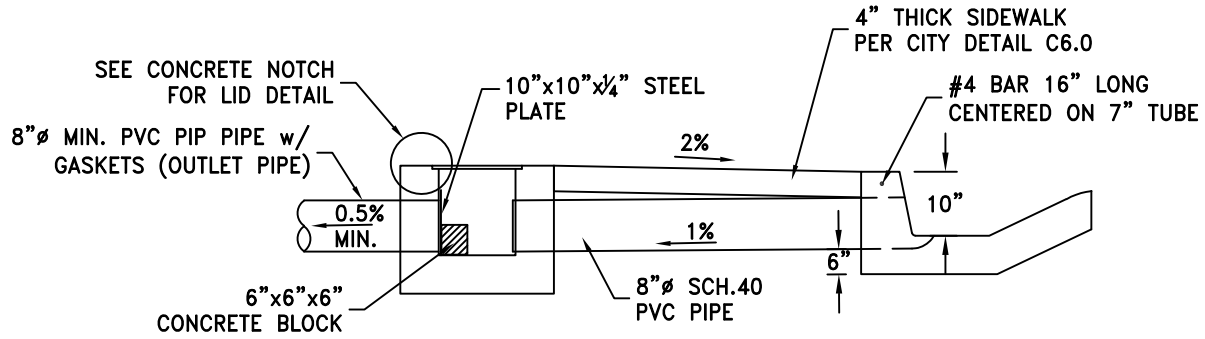

SECTION A-A
N.T.S.

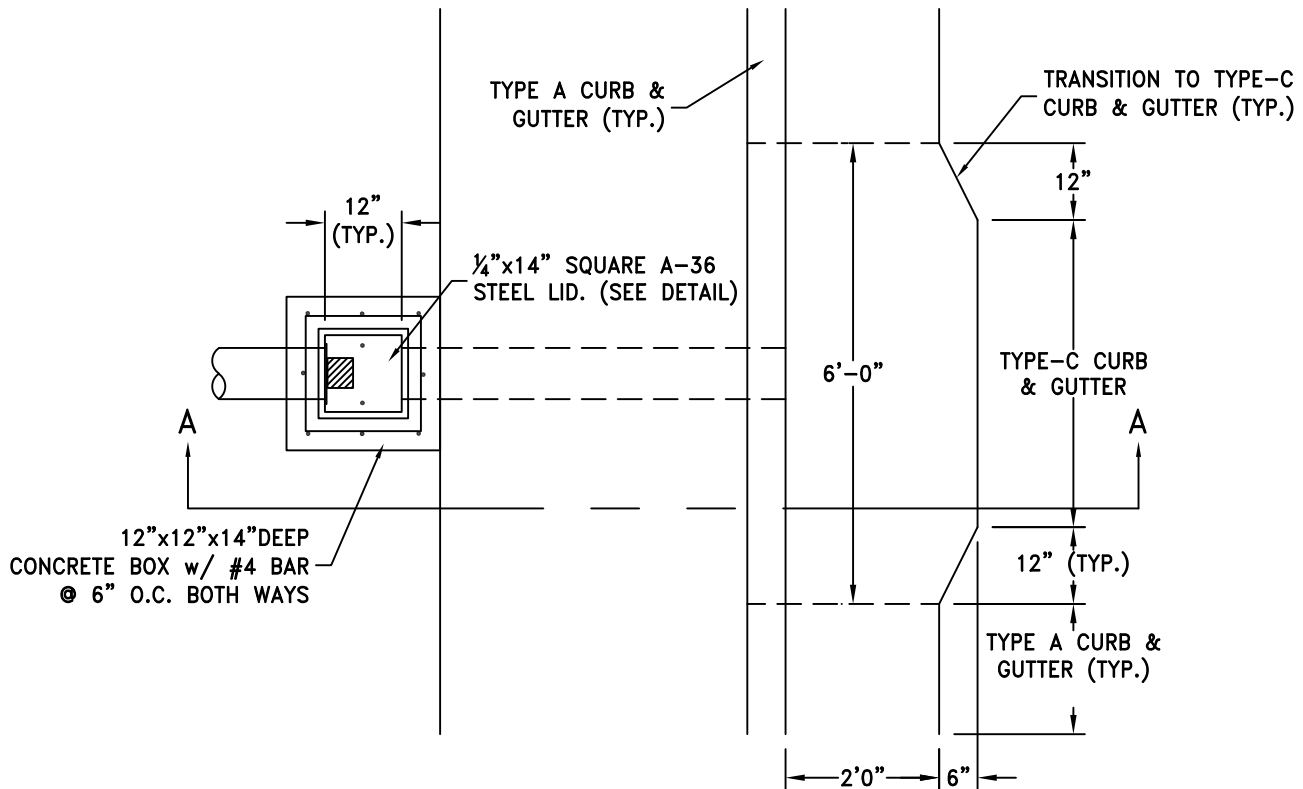

PLAN VIEW
N.T.S.

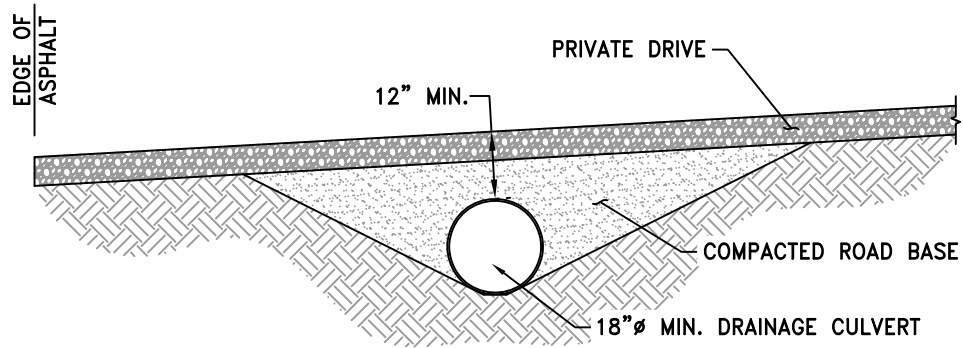

SECTION A-A
N.T.S.

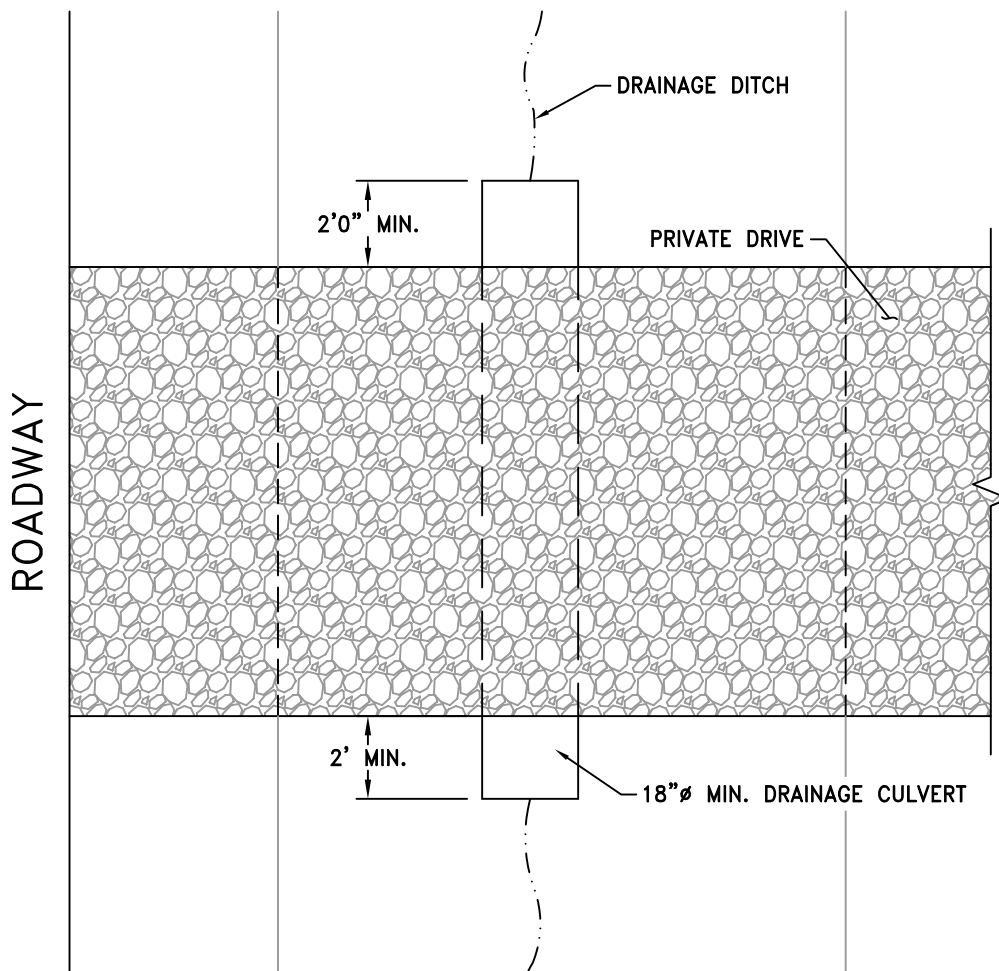

PLAN VIEW
N.T.S.

NOTES:

1. ALL PIPE & INSTALLATION TO MEET CITY STANDARDS.
2. CULVERT TO HAVE A MINIMUM SLOPE OF 0.30%.



ENOCH CITY
900 E MIDVALLEY RD
Enoch, UT 84721
Tel. (435) 586-1119

**BORROW DITCH
DRIVEWAY ACCESS**

SCALE:
N.T.S.
DATE:
DEC. 2022

DETAIL No.:

D9.0

SHEET:
1 of 1

ENOCH CITY MINIMUM TESTING REQUIREMENTS

DESCRIPTION	TEST / QUANTITY	QUANTITY	TESTS REQ'D
ROAD EMBANKMENT DENSITY TESTS	1/500 C.Y.	C.Y.	
ROAD SUBGRADE DENSITY TESTS	1/1,000 S.Y.	S.Y.	
TRENCH DENSITY TESTS			
STORM DRAINS / CULVERTS	2/200 L.F. OF TRENCH	L.F.	
STORM DRAIN MANHOLES / INLET BOX	2/MANHOLE OR BOX	EACH	
IRRIGATION LINE	2/200 L.F. OF TRENCH	L.F.	
WATER LINE (INCLUDES F. H. & SERVICE LATERALS)	2/200 L.F. OF TRENCH	L.F.	
SEWER LINE (INCLUDE SERVICE LATERALS)	5/200 L.F. OF TRENCH	L.F.	
SEWER MANHOLE	5/EACH MANHOLE	EACH	
VALVES	2/VALVE OR VALVE SET	EACH	
UTILITY CONDUITS	2/200 L.F. OF TRENCH	L.F.	
ROAD PIT RUN DENSITY TESTS	1/7,000 S.F.	S.F.	
ROAD PIT RUN THICKNESS TESTS	1/5,000 S.F.	S.F.	
ROAD BASE COURSE DENSITY TESTS	1/7,000 S.F.	S.F.	
ROAD BASE THICKNESS TESTS	1/5,000 S.F.	S.F.	
CURB/GUTTER BASE DENSITY TESTS	1/300 L.F.	L.F.	
SIDEWALK BASE DENSITY TESTS	1/300 L.F.	L.F.	
ASPHALT EXTRACTION TESTS	1/500 TONS OR 1 PER DAY WHICHEVER IS MORE	TON	
ASPHALT DENSITY TESTS	1/7,000 S.F.	S.F.	
ASPHALT THICKNESS TESTS	1/10,000 S.F.	S.F.	
CONCRETE CYLINDER BREAKS	3/50 C.Y.	C.Y.	
CONCRETE AIR ENTRAINMENT	1 IF INITIAL TEST PASSES	LOADS	
CONCRETE SLUMP TESTS	1 IF INITIAL TEST PASSES	LOADS	
ROAD BASE GRADATION TEST	1/15,000 S.F.	S.F.	
CURB & GUTTER BASE COURSE GRAD.	1/2,000 L.F.	L.F.	
CURB & GUTTER THICKNESS TEST	1/200 L.F.	L.F.	
SIDEWALK THICKNESS TEST	1/200 L.F.	L.F.	



ENOCH CITY
900 E MIDVALLEY RD
Enoch, UT 84721
Tel. (435) 586-1119

MINIMUM TESTING REQUIREMENTS

SCALE:
N.T.S.
DATE:
DEC. 2022

DETAIL No.:

T1.0

SHEET:
1 of 1

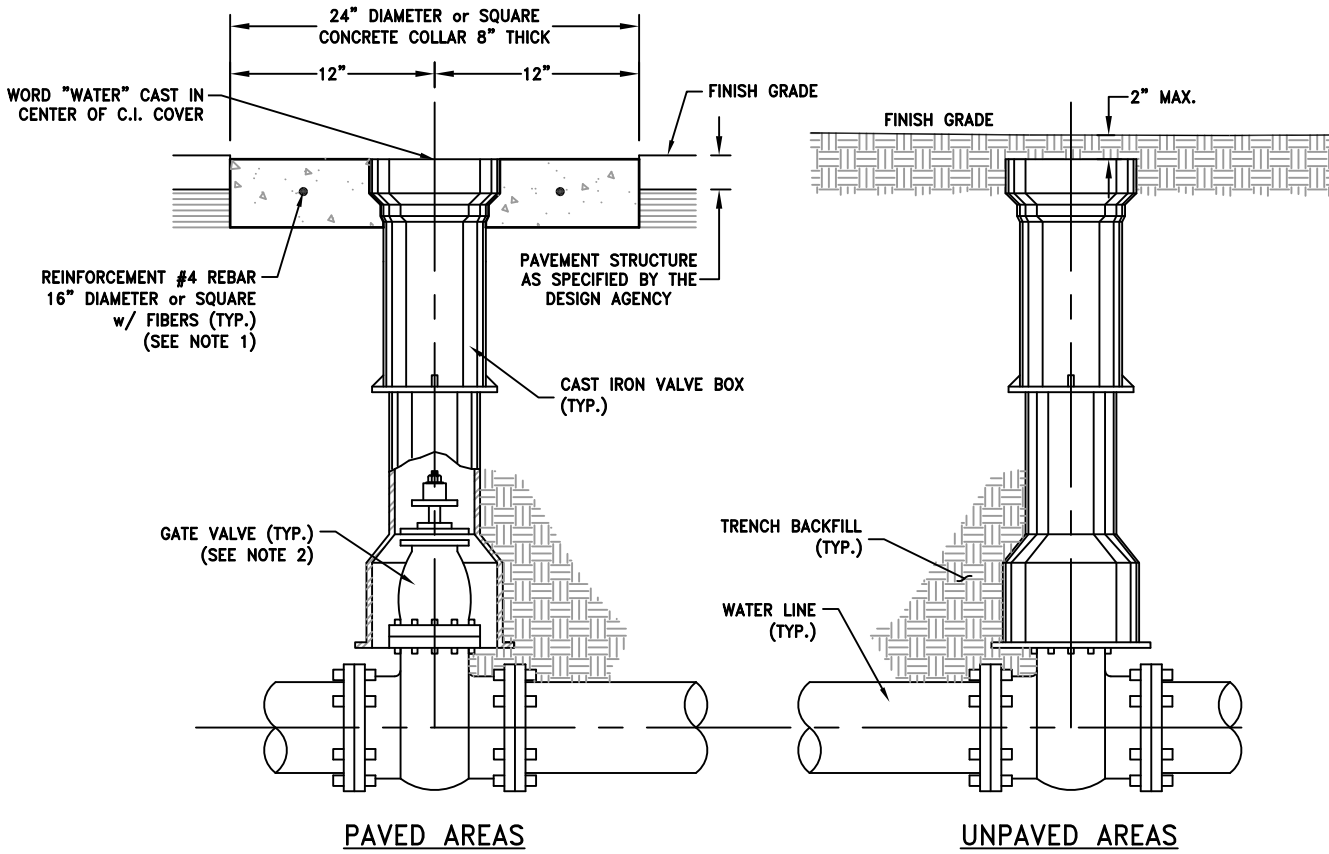

WATER VALVE BOX DETAIL
N.T.S.

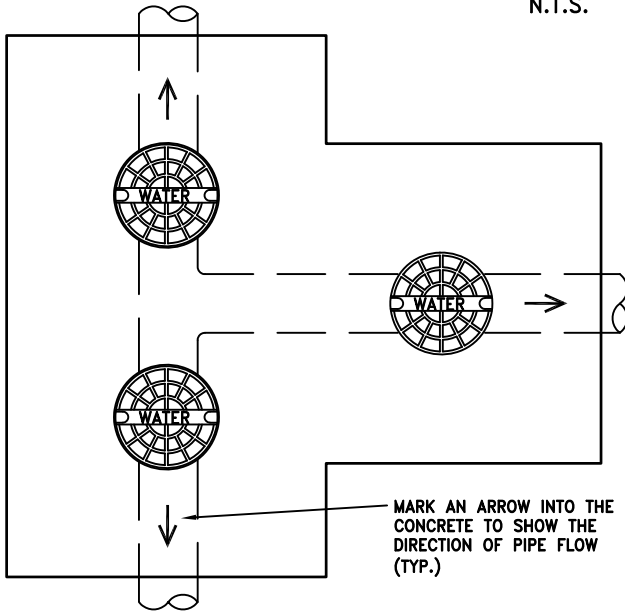

VALVE COLLAR DETAIL
N.T.S.

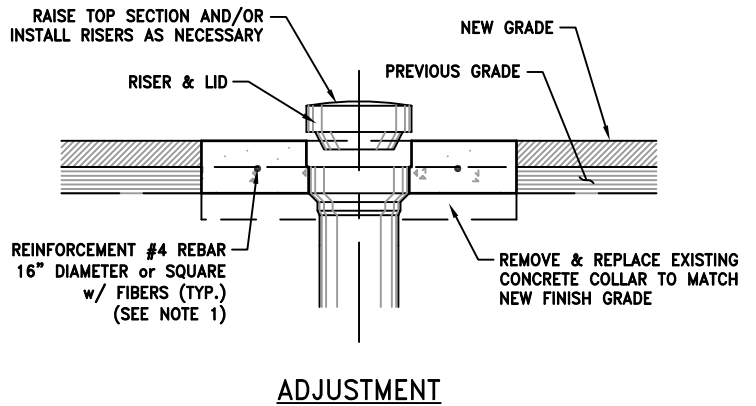

NOTES:

1. TOP OF VALVE BOX AND CONCRETE COLLAR TO BE 1/4" BELOW FINAL STREET GRADE.
2. IF TOP OF VALVE NUT IS MORE THAN 4'0" DEEP, THEN VALVE STEM EXTENSION IS REQUIRED. SEE VALVE STEM EXTENSION DETAIL W1.2.

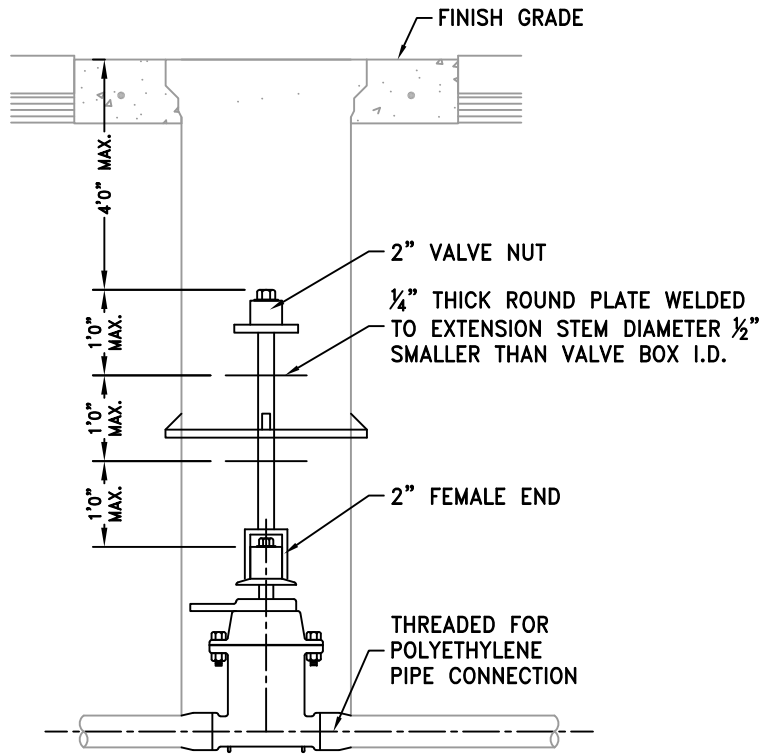

VALVE EXTENSION DETAIL
N.T.S.

NOTES:

1. TOP OF VALVE BOX AND CONCRETE COLLAR TO BE $\frac{1}{4}$ " BELOW FINAL STREET GRADE.

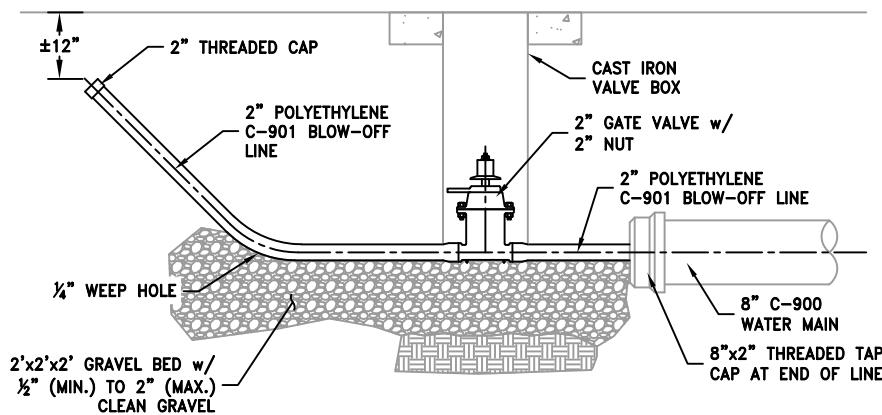

TEMPORARY WATER LINE BLOW-OFF DETAIL
N.T.S.

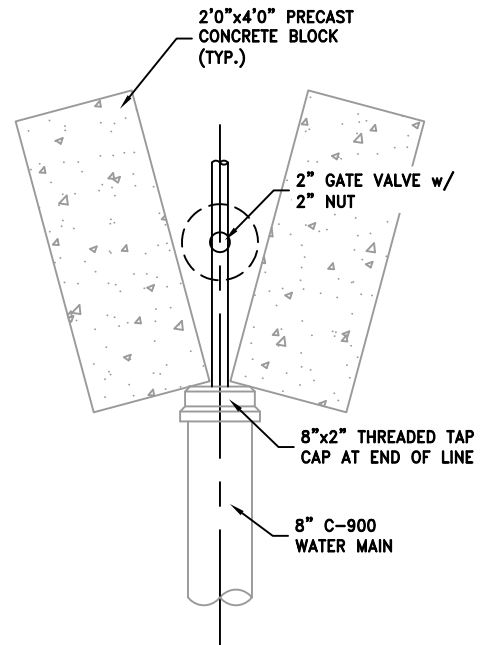

ENOCH CITY
900 E MIDVALLEY RD
Enoch, UT 84721
Tel. (435) 586-1119

**WATER VALVE
EXTENSION &
BLOW-OFF**

SCALE:
N.T.S.
DATE:
DEC. 2022

DETAIL No.:

W1.2

SHEET:
1 of 1

NOTES:

1. TOP OF VALVE BOX AND CONCRETE COLLAR TO BE 1/4" BELOW FINAL STREET GRADE.
2. WATER LINES MAY BE BLOWN OFF THRU FIRE HYDRANTS.
3. FIRE HYDRANTS TO HAVE A MINIMUM 3'0" BURY w/ EXTENSIONS AS REQUIRED.
4. FIRE HYDRANT SHALL BE 3" MIN. & 6" MAX. MEASURED ANYWHERE ON THE FLANGE TO THE TOP BACK OF SIDEWALK.
5. MECHANICAL JOINTS AT ALL FITTINGS (IE: BENDS, TEES, CROSSES & VALVES) SHALL HAVE THRUST BLOCKS.
6. MECHANICAL JOINTS AT ALL FITTINGS SHALL BE WRAPPED WITH TWO LAYERS OF 6mm POLYETHYLENE SO THAT ALL BOLTS, NUTS & CONNECTIONS ARE COVERED. POLYETHYLENE TO BE PULLED UP OVER BONNET OF VALVE TO COVER BOLTS. DUCT TAPE or WIRE TO BE USED TO SECURE PLASTIC WRAPPING IN PLACE.

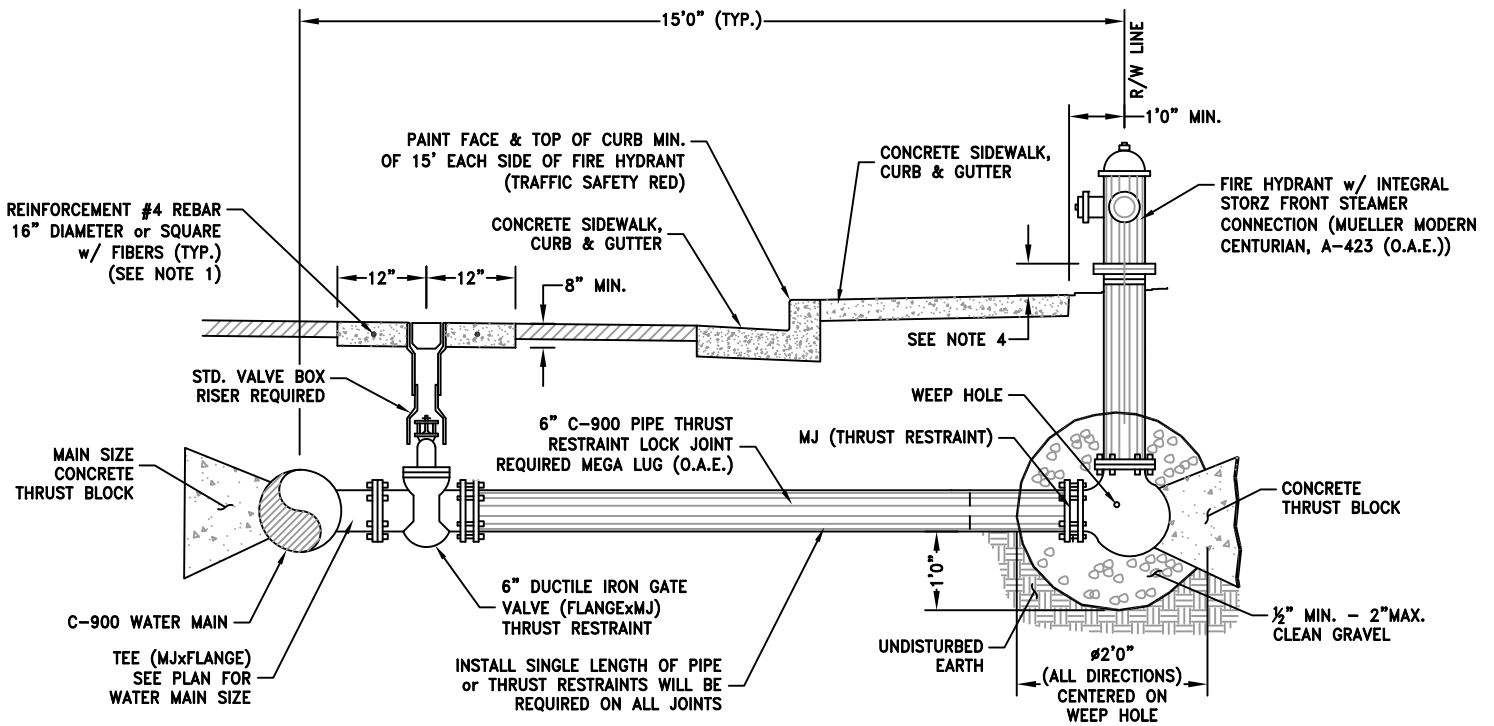

ENOCH CITY
 900 E MIDVALLEY RD
 Enoch, UT 84721
 Tel. (435) 586-1119

FIRE HYDRANT

SCALE:
 N.T.S.
 DATE:
 MAY 2023

DETAIL No.:

W2.0

SHEET:
 1 of 1

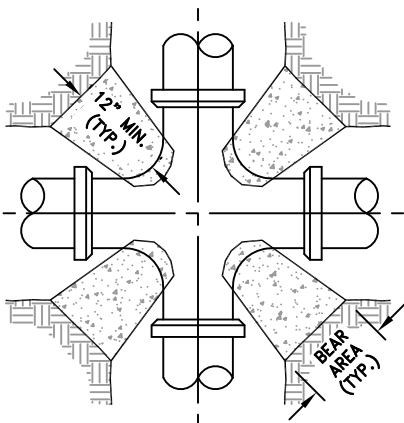

FIGURE 1
CROSS

REQUIRED ONLY IF ANY LENGTH OF PIPE LEG IS LESS THAN 60'0" LONG.

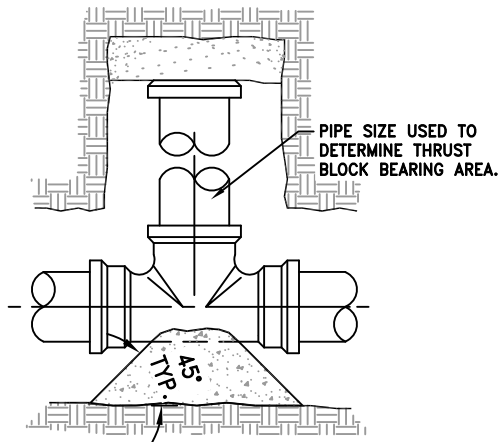

FIGURE 2
TEE, PLUG or CAP

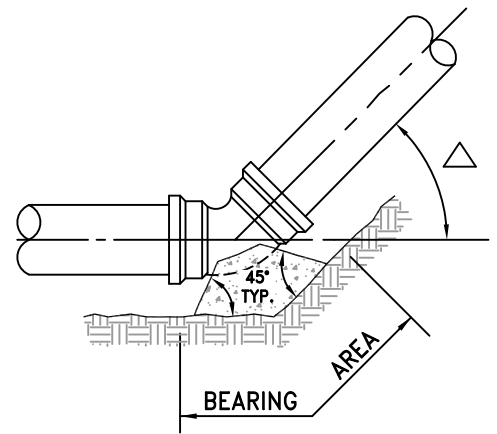

FIGURE 3
HORIZONTAL or UPWARD
VERTICAL BEND

NOTES:

1. ALL FITTINGS & EXPOSED REBAR SHALL BE WRAPPED WITH TWO LAYERS OF 6 MIL. POLYETHYLENE SO THAT ALL BOLTS, NUTS & CONNECTIONS ARE COVERED. POLYETHYLENE TO BE PULLED UP OVER BONNET OF VALVE TO COVER BOLTS. DUCT TAPE or WIRE TO BE USED TO SECURE PLASTIC WRAPPING IN PLACE.
2. ALL CONCRETE SHALL BE CLASS C 3000 P.S.I. MINIMUM 28 DAYS COMPRESSIVE STRENGTH.
3. PLACE CONCRETE AGAINST UNDISTURBED EARTH.
4. TABLE DENOTES MINIMUM BEARING AREA OR VOLUME OF THRUST BLOCK. SPECIAL DESIGN FOR EACH INSTALLATION IS REQUIRED IF ALLOWABLE SOIL BEARING CAPACITY IS LESS THAN 3000 P.S.F.
5. VERTICAL SURFACES NOT BEARING AGAINST UNDISTURBED EARTH SHALL BE FORMED.
6. KEEP CONCRETE AWAY FROM FLANGE BOLTS AND FITTINGS.
7. 90° ELBOWS IN WATER MAINS ARE ONLY ALLOWED AS APPROVED BY THE WATER SUPERINTENDENT.
8. THRUST BLOCK BEARING AREA BASED ON LARGEST PIPE I.D. THAT THRUST BLOCK IS SUPPORTING.
9. MECHANICAL JOINTS AT ALL FITTINGS (IE: BENDS, TEES, CROSSES & VALVES) SHALL HAVE THRUST BLOCKS.

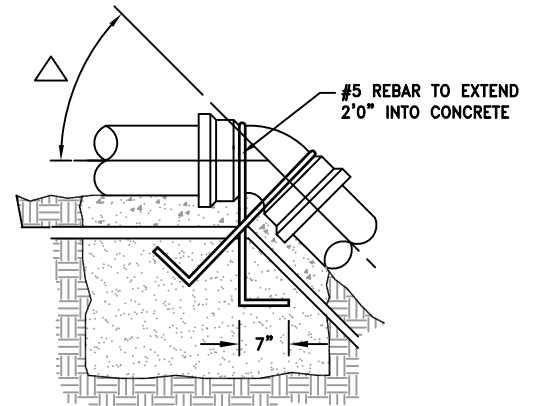

FIGURE 4
DOWNWARD VERTICAL BEND

PIPE I.D.	BEARING AREA, SQUARE FEET						VOLUME OF CONC. CU.YD.		
	FIGURE 1	FIGURE 2	FIGURE 3, △				FIGURE 4, △		
			90°	45°	22-1/2°	11-1/4°	45°	22-1/2°	11-1/4°
4"	2	2	2	1	1	1	1.0	.5	.5
6"	2	3	3	2	1	1	1.5	1.0	.5
8"	2	5	6	3	2	1	2.0	1.0	.5
10"	3	7	10	5	3	1	4.0	2.0	1.0
12"	3	10	14	8	4	2			
14"	4	14	20	10	5	3			
16"	4	20	24	12	7	4			
18"	5	24	30	16	10	5			
20"	5	28	40	20	12	6			



ENOCH CITY
900 E MIDVALLEY RD
Enoch, UT 84721
Tel. (435) 586-1119

THRUST BLOCKS

SCALE:
N.T.S.
DATE:
DEC. 2022

DETAIL No.:

W3.0

SHEET:
1 of 1

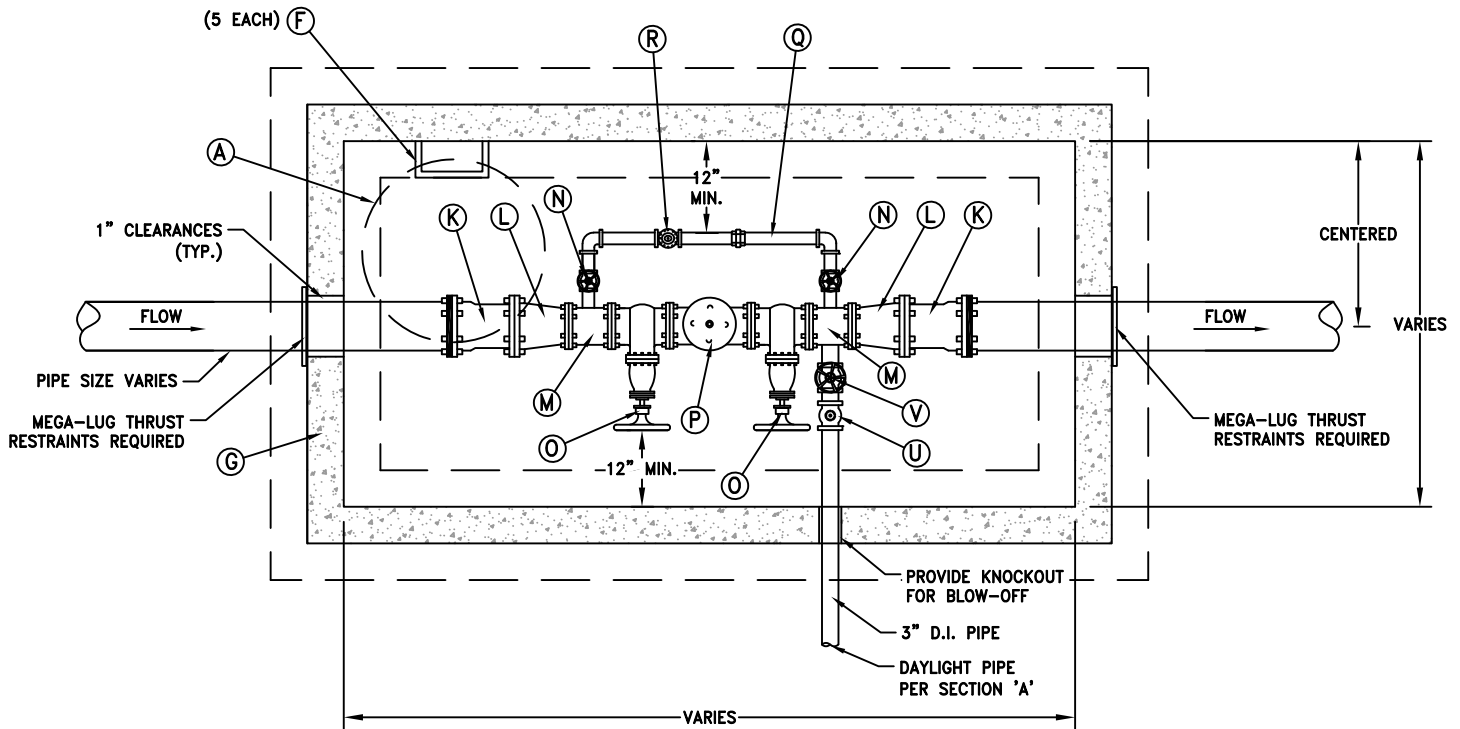

PLAN
N.T.S.

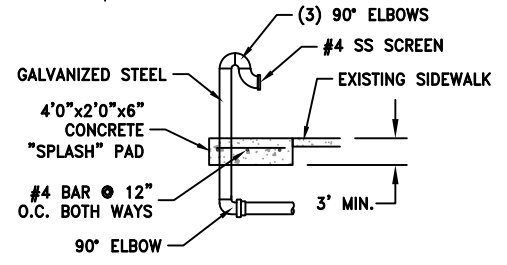

SECTION 'A'
N.T.S.

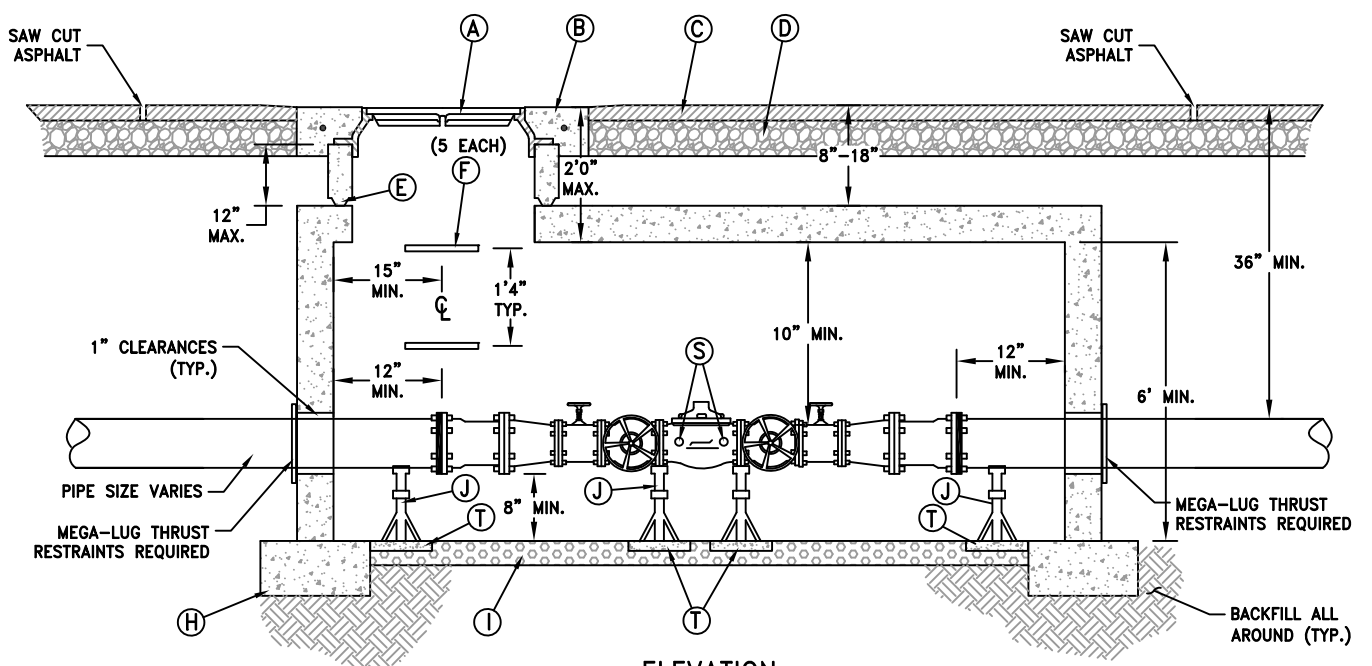

ELEVATION
N.T.S.



ENOCH CITY
900 E MIDVALLEY RD
Enoch, UT 84721
Tel. (435) 586-1119

**6" PRESSURE
REDUCING VALVE
w/ 2" BYPASS**

SCALE:
N.T.S.
DATE:
DEC. 2022

DETAIL No.:

W4.0A

SHEET:
1 of 2

LEGEND

NO.	ITEM	DESCRIPTION
(A)	MANHOLE RING AND COVER (RIBLESS)	D&L A-1180 O.A.E.
(B)	4'0" SQUARE x 8" THICK CONCRETE COLLAR	w/ 40" SQUARE #4 BARS & FIBERS
(C)	3" ASPHALT MAT	
(D)	8" COMPACTED UNTREATED BASE	
(E)	GRADE RING(S)	MUST BE SEALED
(F)	MANHOLE STEP	(M.A. INDUSTRIES INC. O.A.E.)
(G)	CONCRETE VAULT TOP	AMCOR UV6127T O.A.E.
(H)	9"x18" FOOTING w/ (3) #4 BARS	
(I)	4" THICK DRAIN GRAVEL	
(J)	(4) LEVELING JACKS (LENGTH VARIES)	SLIDEWINDER PART #23535 BY BARKER MANUF. CO.
(K)	X" M.J. X FLANGE ADAPTOR	CEMENT LINED
(L)	X"x6" FLANGED REDUCER (IF REQ'D)	CEMENT LINED
(M)	6" FLANGED STEEL SPOOL WITH 2" OUTLET	EPOXY COATED AND LINED
(N)	2" GATE VALVE WITH HANDWHEEL	
(O)	6" GATE VALVE WITH HANDWHEEL	NON-RISING STEM
(P)	6" PRESSURE REDUCING VALVE	AWWA APPROVED (WATTS, O.A.E.)
(Q)	2" K-COPPER PIPE AND FITTINGS AS SHOWN	
(R)	2" PRESSURE REDUCING VALVE	AWWA APPROVED (WATTS, O.A.E.)
(S)	¾" TAPS w/ PRESSURE GUAGE	2½", 0-300 PSI, GLYCERIN FILLED
(T)	12"x12"x2" CONCRETE BLOCK	
(U)	BLOW-OFF PRV	AWWA APPROVED (WATTS, O.A.E.)
(V)	3" GATE VALVE w/ HANDWHEEL	

NOTES:

- UNLESS OTHERWISE SHOWN, ALL MATERIALS PER ENOCH CITY ENGINEERING STANDARDS.
- CONCRETE VAULT LENGTH AND WIDTH SHALL BE SUFFICIENT TO CONTAIN ALL FITTINGS AND MAINTAIN OPERATING CLEARANCE FROM WALLS.
- VAULTS ARE DESIGNED TO MEET ASTM C858 WITH AASHTO HS-20 LOADING.
- ALL PIPE MATERIALS AND FITTINGS MUST BE RATED FOR WATER SYSTEM PRESSURE.



ENOCH CITY
900 E MIDVALLEY RD
Enoch, UT 84721
Tel. (435) 586-1119

Copyright © 2023

6" PRESSURE
REDUCING VALVE
w/ 2" BYPASS

SCALE:
N.T.S.
DATE:
DEC. 2022

DETAIL No.:

W4.0B

SHEET:
2 of 2

METER SIZE	BOX DIAMETER	BOX COLOR	D&L RING & COVER, OAE	FORD SETTER, OAE	CURB STOP	SERVICE BOX
1"	18"	WHITE	L-2241 (SEE NOTE 6)	VBHC 74-18W-44-44-G or Q	FORD MODEL B11-444 (O.A.E.) 1" BALL VALVE 1" FM I.P.T. x 1" FM I.P.T.	FORD-EA2 40-40-30R (O.A.E.)

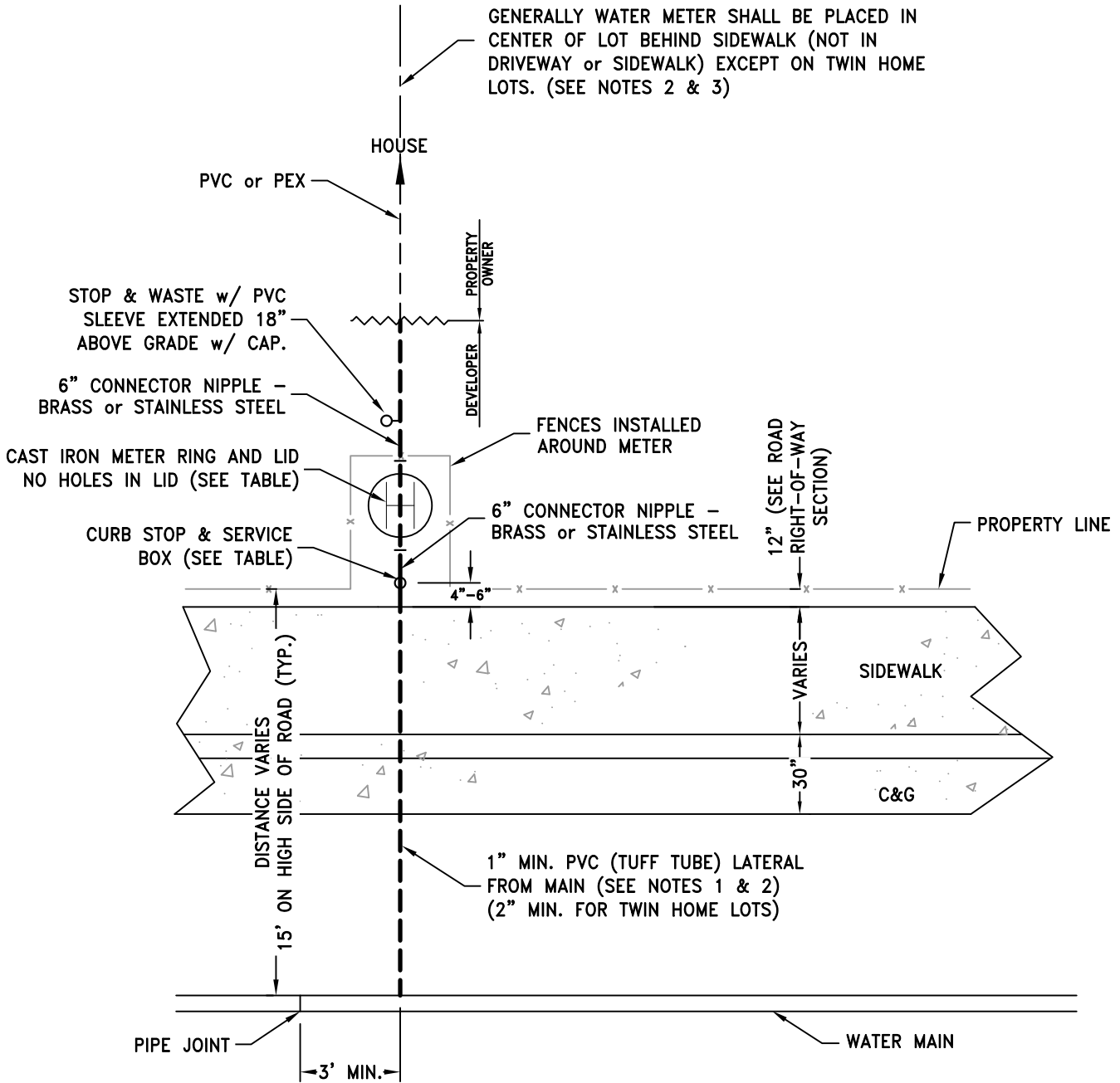

PLAN
N.T.S.



ENOCH CITY
900 E MIDVALLEY RD
Enoch, UT 84721
Tel. (435) 586-1119

1" WATER METER

SCALE:
N.T.S.
DATE:
MAY 2023

DETAIL No.:

W5.1A

SHEET:
1 of 2

METER SIZE	BOX DIAMETER	BOX COLOR	D&L RING & COVER, OAE	FORD SETTER, OAE	CURB STOP	SERVICE BOX
1"	18"	WHITE	L-2241 (SEE NOTE 6)	VBHC 74-18W-44-44-G or Q	FORD MODEL B11-444 (O.A.E.) 1" BALL VALVE 1" FM I.P.T. x 1" FM I.P.T.	FORD-EA2 40-40-30R (O.A.E.)

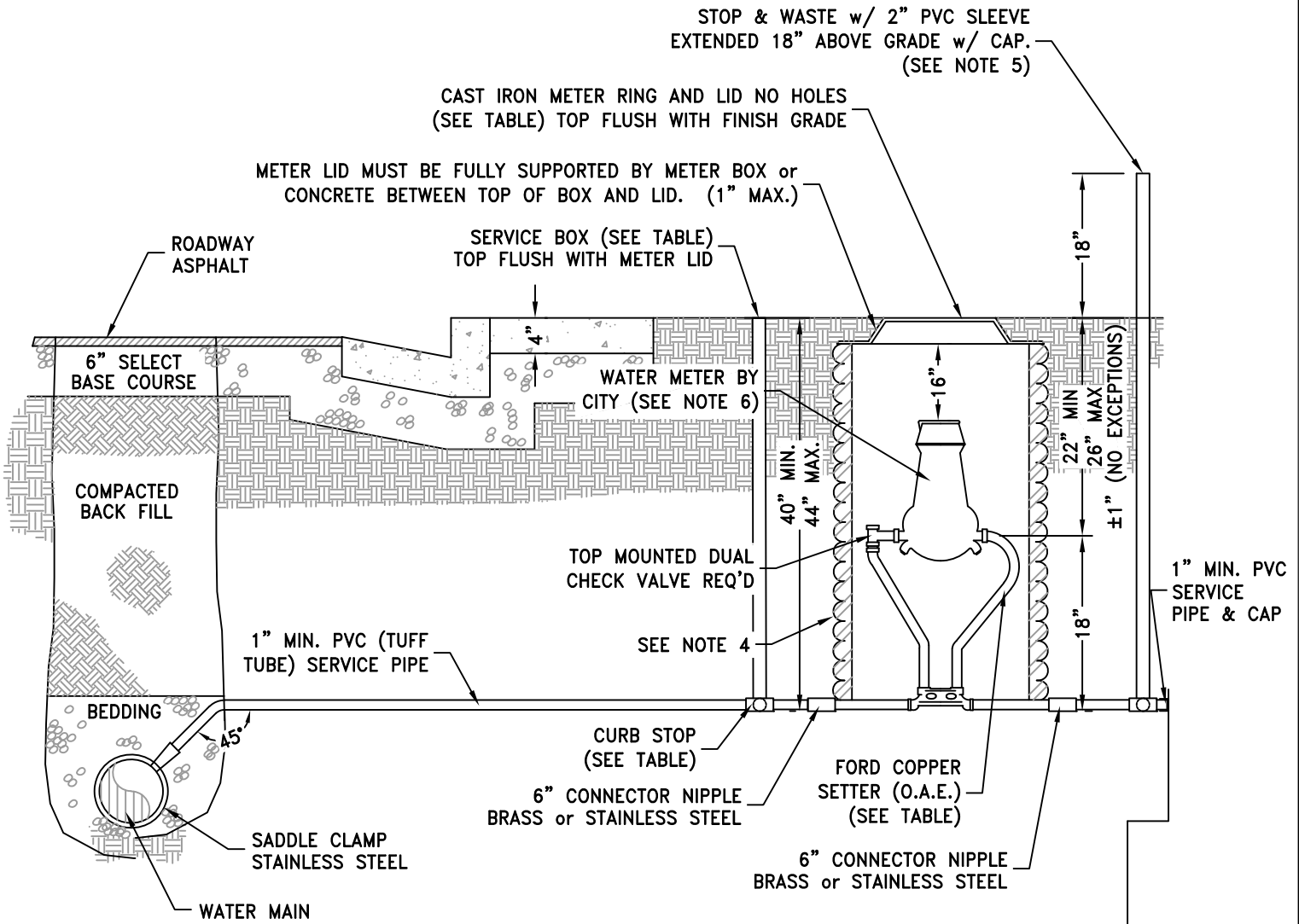

SECTION
N.T.S.

DEVELOPER PROPERTY OWNER

NOTES:

1. 3/4" LATERAL ALLOWED ONLY BY APPROVAL OF THE CITY.
2. ON TWIN HOME LOTS THE WATER METERS SHALL BE PLACED 10' FROM EACH SIDE OF LOT LINE.
3. ON INDUSTRIAL ZONED ROADS WHERE SIDEWALKS ARE NOT REQUIRED OR INSTALLED THE WATER METERS SHALL BE INSTALLED BEHIND THE CURB & GUTTER.
4. METER BOX HDP A.D.S. N-12 (O.A.E.) CORRUGATED POLYETHYLENE PIPE CORRUGATED EXTERIOR/ SMOOTH INTERIOR (SEE TABLE). BOX TO BE A CONTINUOUS PIECE OF PIPE WITH NO EXTENSIONS.
5. STOP & WASTE NOT REQUIRED TO BE INSTALLED IF SECONDARY WATER IS AVAILABLE.
6. USE D&L B-5018 FOR METER LIDS THAT WILL BE INSET IN CONCRETE.



ENOCH CITY
900 E MIDVALLEY RD
Enoch, UT 84721
Tel. (435) 586-1119

1" WATER METER

SCALE:
N.T.S.
DATE:
MAY 2023

DETAIL No.:

W5.1B

SHEET:
2 of 2

METER SIZE	BARREL DIAMETER	BARREL COLOR	D&L RING & COVER, OAE	FORD SETTER, OAE	CURB STOP	SERVICE BOX
1½"	24"ø	WHITE	L-2241 (SEE NOTE 6)	VBHH 76-18-44-66-G or Q	FORD MODEL B11-444 (O.A.E.) 1½" BALL VALVE 1½" FM I.P.T. x 1½" FM I.P.T.	FORD-EA2 40-40-30R (O.A.E.)

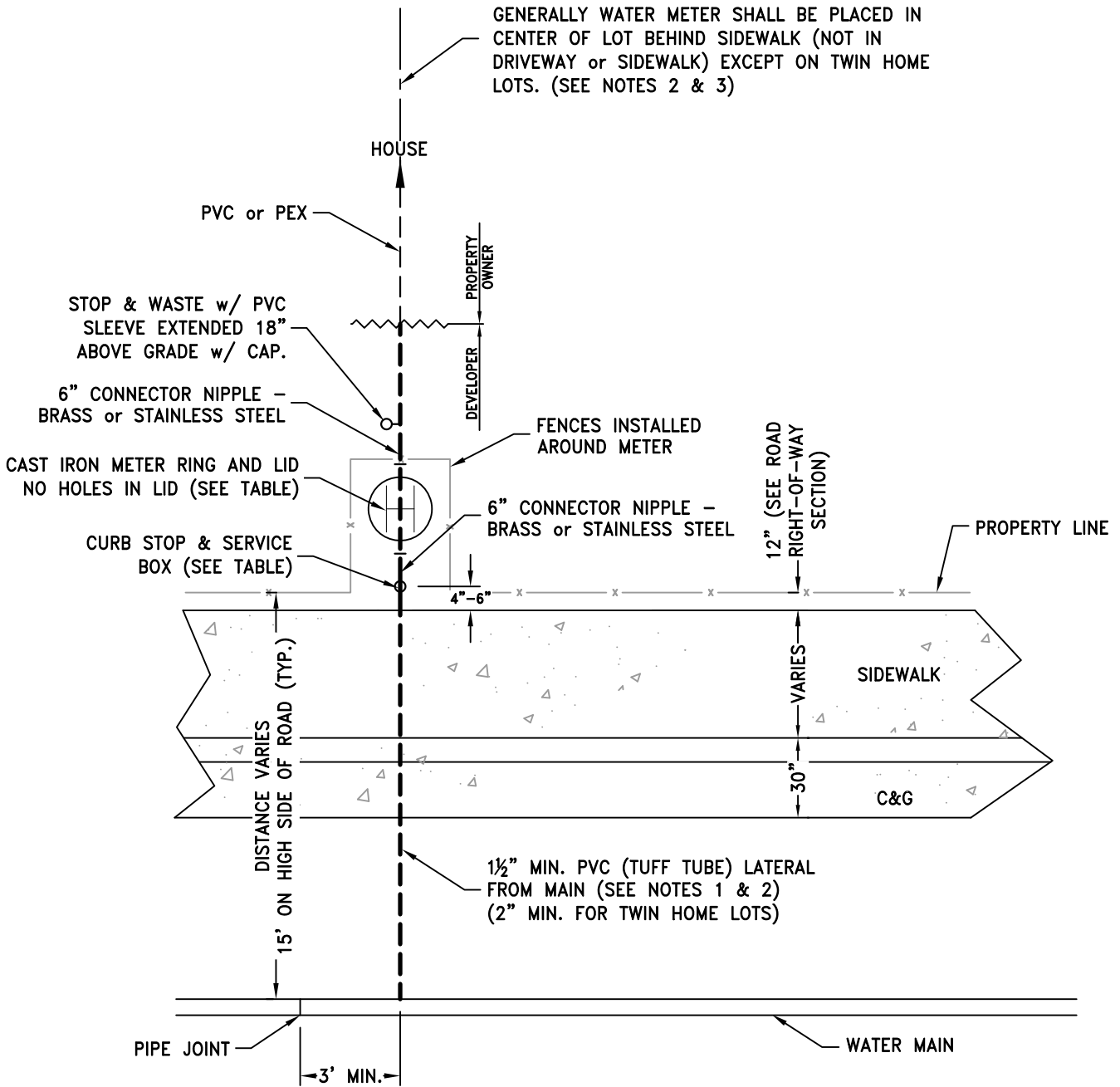

PLAN
N.T.S.



ENOCH CITY
900 E MIDVALLEY RD
Enoch, UT 84721
Tel. (435) 586-1119

1½" WATER METER

SCALE:
N.T.S.
DATE:
DEC. 2022

DETAIL No.:

W5.2A

SHEET:
1 of 2

METER SIZE	BARREL DIAMETER	BARREL COLOR	D&L RING & COVER, OAE	FORD SETTER, OAE	CURB STOP	SERVICE BOX
1½"	24"Ø	WHITE	L-2241 (SEE NOTE 6)	VBHH 76-18-44-66-G or Q	FORD MODEL B11-444 (O.A.E.) 1½" BALL VALVE 1½" FM I.P.T. x 1½" FM I.P.T.	FORD-EA2 40-40-30R (O.A.E.)

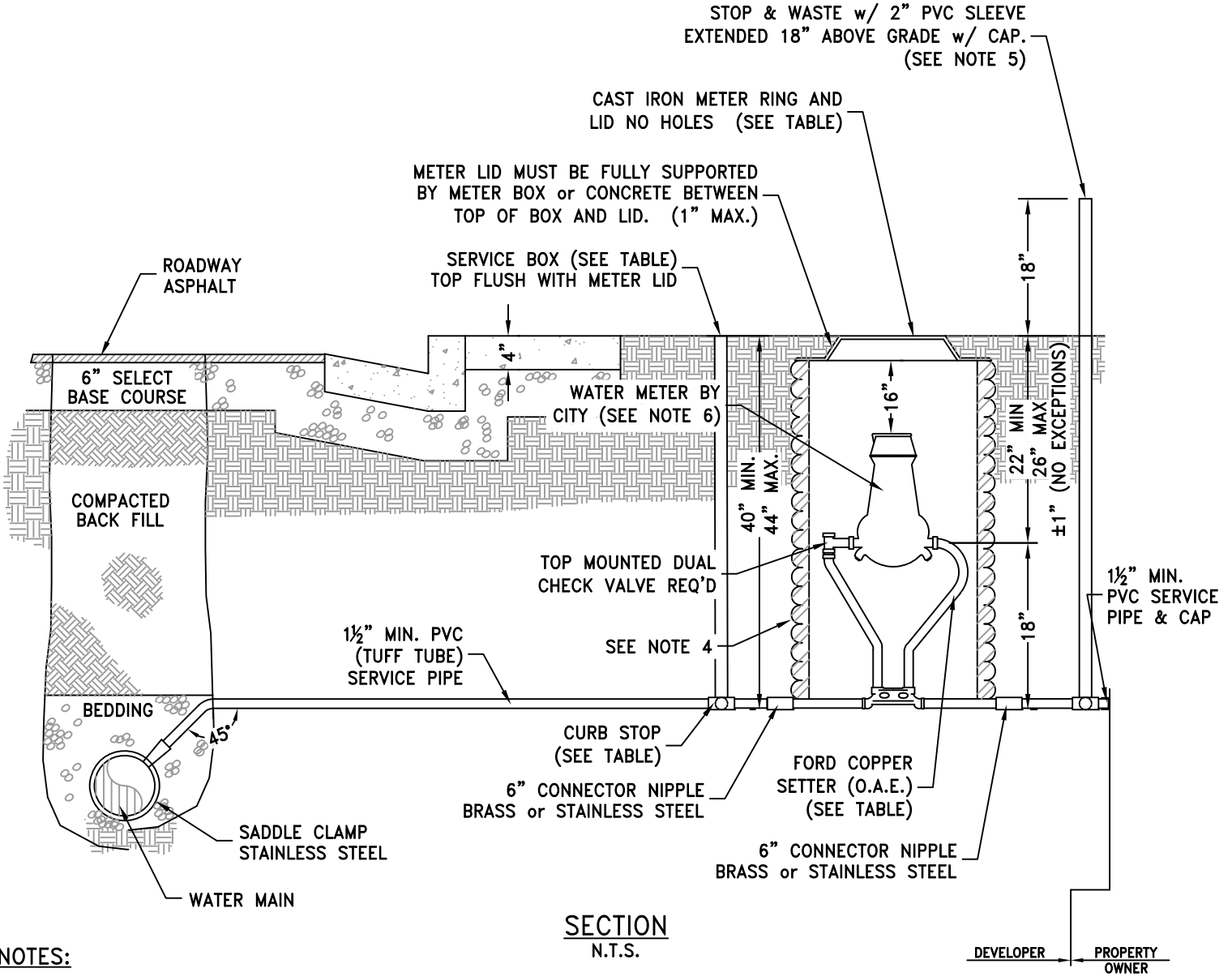

NOTES:

- ¾" LATERAL ALLOWED ONLY BY APPROVAL OF THE CITY.
- ON TWIN HOME LOTS THE WATER METERS SHALL BE PLACED 10' FROM EACH SIDE OF LOT LINE.
- ON INDUSTRIAL ZONED ROADS WHERE SIDEWALKS ARE NOT REQUIRED OR INSTALLED THE WATER METERS SHALL BE INSTALLED BEHIND THE CURB & GUTTER.
- METER BOX HDP A.D.S. N-12 (O.A.E.) CORRUGATED POLYETHYLENE PIPE CORRUGATED EXTERIOR/ SMOOTH INTERIOR (SEE TABLE). BOX TO BE A CONTINUOUS PIECE OF PIPE WITH NO EXTENSIONS.
- STOP & WASTE NOT REQUIRED TO BE INSTALLED IF SECONDARY WATER IS AVAILABLE.
- USE D&L B-5020 FOR METER BARRELS THAT WILL BE INSET IN CONCRETE.



ENOCH CITY
900 E MIDVALLEY RD
Enoch, UT 84721
Tel. (435) 586-1119

1½" WATER METER

SCALE:
N.T.S.
DATE:
DEC. 2022

DETAIL No.:

W5.2B

SHEET:
2 of 2

METER SIZE	BARREL DIAMETER	BARREL COLOR	D&L RING & COVER, OAE	FORD SETTER, OAE	CURB STOP	SERVICE BOX
2"	30"ø	BLACK	L-2241 (SEE NOTE 6)	VBHH 77-18-44-77-G or Q	FORD MODEL B11-444 (O.A.E.) 1½" BALL VALVE 1½" FM I.P.T. x 1½" FM I.P.T.	FORD-EA2 40-40-30R (O.A.E.)

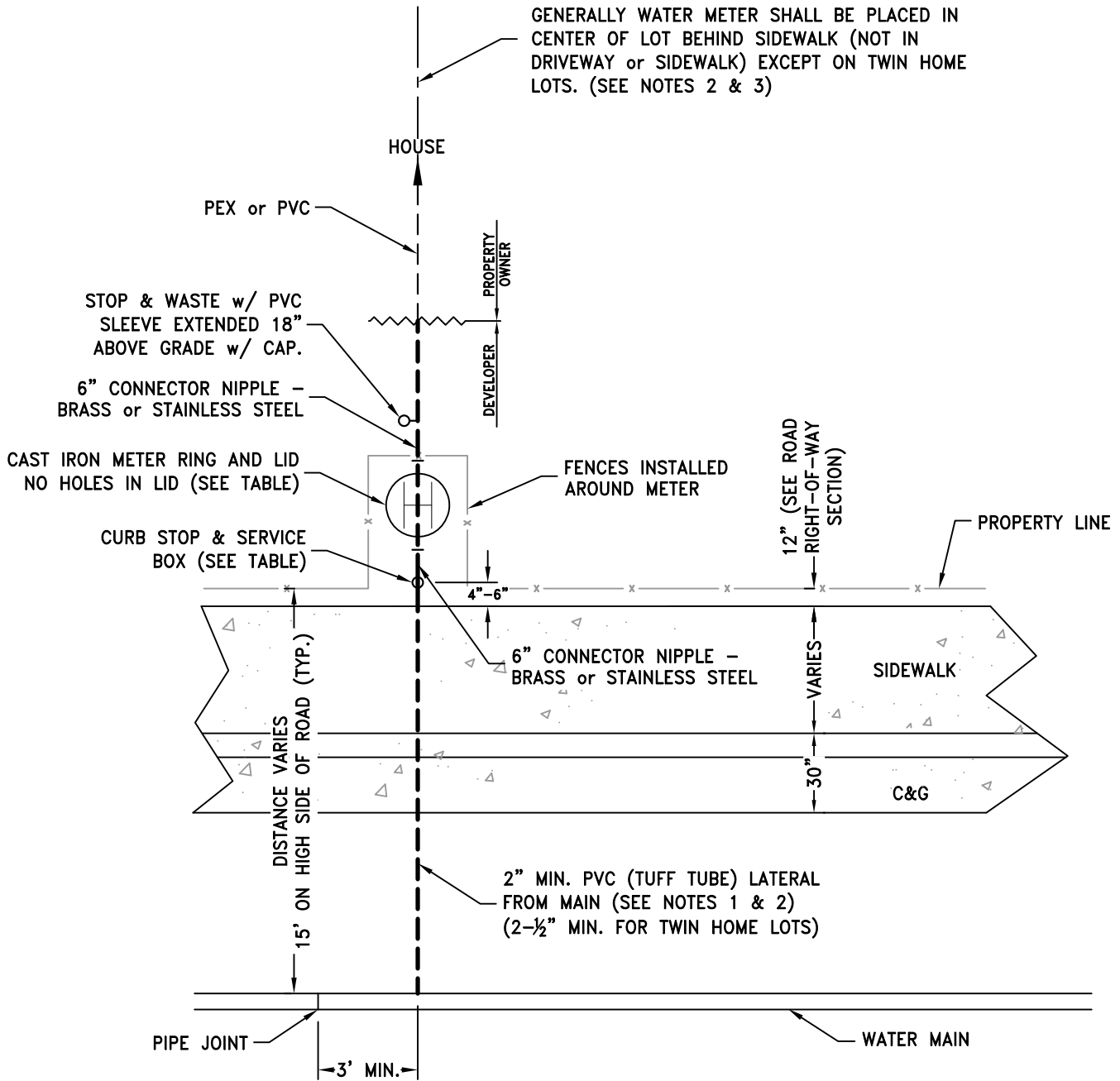

PLAN

N.T.S.



ENOCH CITY
900 E MIDVALLEY RD
Enoch, UT 84721
Tel. (435) 586-1119

2" WATER METER

SCALE:
N.T.S.
DATE:
DEC. 2022

DETAIL No.:

W5.3A

SHEET:
1 of 2

METER SIZE	BARREL DIAMETER	BARREL COLOR	D&L RING & COVER, OAE	FORD SETTER, OAE	CURB STOP	SERVICE BOX
2"	30"Ø	BLACK	L-2241 (SEE NOTE 6)	VBHH 77-18-44-77-G or Q	FORD MODEL B11-444 (O.A.E.) 1½" BALL VALVE 1½" FM I.P.T. x 1½" FM I.P.T.	FORD-EA2 40-40-30R (O.A.E.)

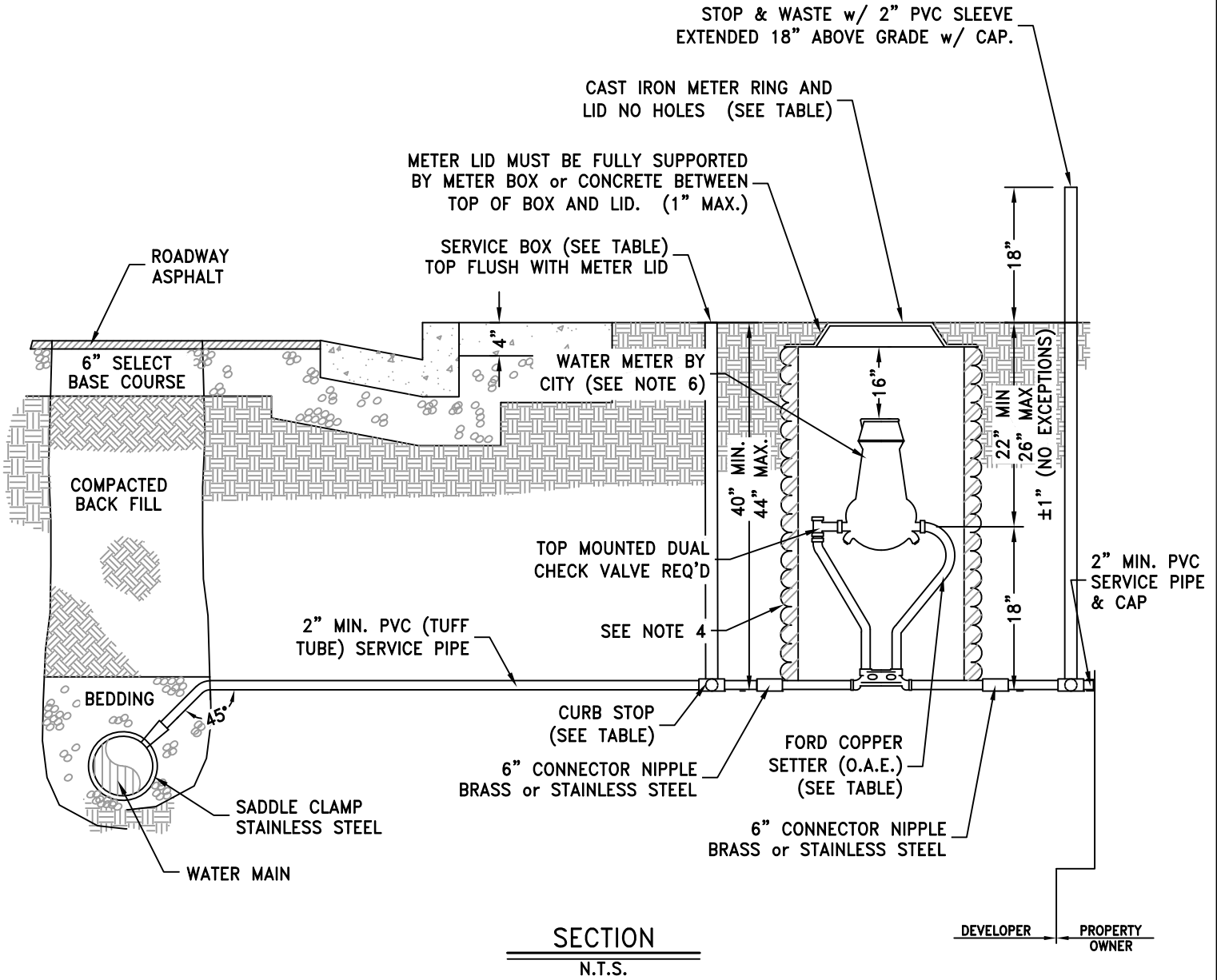

NOTES:

1. ¾" LATERAL ALLOWED ONLY BY APPROVAL OF THE CITY.
2. ON TWIN HOME LOTS THE WATER METERS SHALL BE PLACED 10' FROM EACH SIDE OF LOT LINE.
3. ON INDUSTRIAL ZONED ROADS WHERE SIDEWALKS ARE NOT REQUIRED OR INSTALLED THE WATER METERS SHALL BE INSTALLED BEHIND THE CURB & GUTTER.
4. METER BOX HDP A.D.S. N-12 (O.A.E.) CORRUGATED POLYETHYLENE PIPE CORRUGATED EXTERIOR/ SMOOTH INTERIOR (SEE TABLE). BOX TO BE A CONTINUOUS PIECE OF PIPE WITH NO EXTENSIONS.
5. STOP & WASTE NOT REQUIRED TO BE INSTALLED IF SECONDARY WATER IS AVAILABLE.
6. USE D&L B-5024 FOR METER BARRELS THAT WILL BE INSET IN CONCRETE.



ENOCH CITY
900 E MIDVALLEY RD
Enoch, UT 84721
Tel. (435) 586-1119

2" WATER METER

SCALE:
N.T.S.
DATE:
MAY 2023

DETAIL No.:

W5.3B

SHEET:
2 of 2

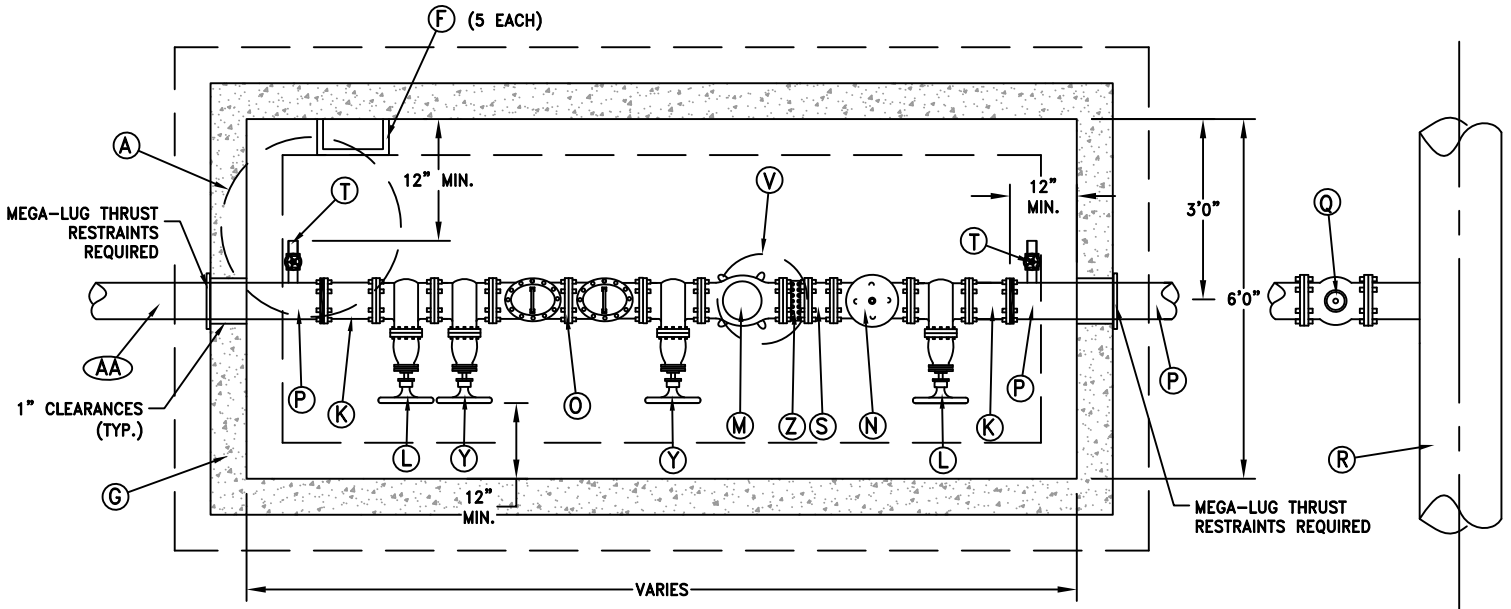

PLAN
N.T.S.

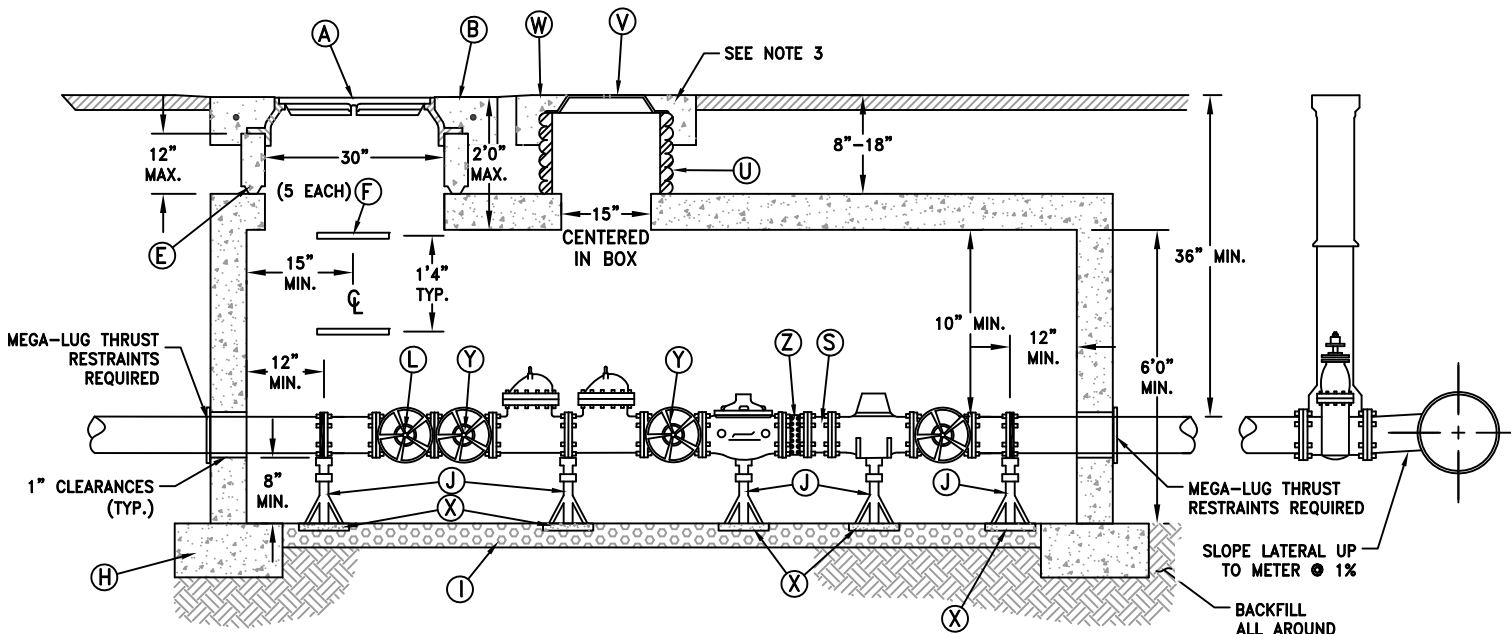

ELEVATION
N.T.S.

	<p>ENOCH CITY 900 E MIDVALLEY RD Enoch, UT 84721 Tel. (435) 586-1119</p>	<p>3" - 4" WATER METER (COMBINED CULINARY & FIRE SPRINKLER FLOWS)</p>	<p>SCALE: N.T.S. DATE: DEC. 2022</p>	<p>DETAIL No.: W5.4A SHEET: 1 of 2</p>
--	--	--	--	---

LEGEND

NO.	ITEM	DESCRIPTION
(A)	MANHOLE RING AND COVER (RIBLESS)	D&L A-1180 O.A.E.
(B)	4'0" SQUARE x 8" THICK CONCRETE COLLAR	w/ 40" SQUARE #4 BARS & FIBERS
(C)	NOT USED	
(D)	NOT USED	
(E)	GRADE RING(S)	MUST BE SEALED
(F)	MANHOLE STEP	(M.A. INDUSTRIES INC. O.A.E.)
(G)	CONCRETE VAULT TOP	AMCOR UV6127T O.A.E.
(H)	9"x18" FOOTING w/ (3) #4 BARS	
(I)	4" THICK DRAIN GRAVEL	
(J)	(5) LEVELING JACKS (LENGTH VARIES)	SLIDEWINDER PART #23535 BY BARKER MANUF. CO.
(K)	6" MIN. FLANGE ADAPTOR	CEMENT LINED
(L)	GATE VALVE WITH HANDWHEEL	NON-RISING STEM
(M)	FLOW METER (PURCHASED FROM CITY)	MACH 10
(N)	PRESSURE REDUCING VALVE (IF REQ'D)	AWWA APPROVED
(O)	DOUBLE CHECK DETECTOR VALVE (DCDA)	AWWA APPROVED
(P)	DUCTILE IRON PIPE or COPPER PIPE	CEMENT LINED OR COPPER
(Q)	GATE VALVE WITH BOX	SEE STANDARD DETAIL W1.0
(R)	FIRE LOOP or CITY WATER MAIN	
(S)	FLANGED SPOOL 12" LONG	
(T)	1½" PIPE TAP WITH GATE VALVE AND 4" NIPPLE	
(U)	18" DIA. HDPE PIPE	PER PIPE SPEC
(V)	RING & LID w/ 2" PUNCHOUT	D&L-2241 O.A.E.
(W)	30"x30"x8" THICK CONCRETE COLLAR	
(X)	12"x12"x2" CONCRETE BLOCK	
(Y)	BACKFLOW ASSEMBLY VALVE	
(Z)	STRAINER (IF REQUIRED)	PURCHASED FROM CITY
(AA)	DUCTILE IRON PIPE or COPPER PIPE (TO 10'0" OUTSIDE OF VAULT)	

NOTES:

1. UNLESS OTHERWISE SHOWN ALL MATERIALS PER ENOCH CITY ENGINEERING STANDARDS.
2. CONCRETE VAULT LENGTH & WIDTH SHALL BE SUFFICIENT TO CONTAIN ALL FITTINGS AND MAINTAIN INDICATED CLEARANCE FROM WALLS.
3. WATER METER LIDS & COVERS SHALL ONLY BE INSTALLED IN LANDSCAPED AREAS UNLESS APPROVED BY WATER SUPERINTENDENT.
4. NOT ALLOWED ON PRIVATE SYSTEMS WITH FIRE HYDRANTS.
5. VAULTS ARE DESIGNED TO MEET ASTM C858 WITH AASHTO HS-20 LOADING.
6. PRV IS REQUIRED FOR 80 PSI PRESSURE OR GREATER.
7. STRAINER IS REQUIRED IF A PRV IS REQUIRED.
8. ALL PIPE MATERIALS AND FITTINGS MUST BE RATED FOR WATER SYSTEM PRESSURE.
9. ONLY NFPA 13R FIRE SPRINKLER SYSTEMS ARE ALLOWED WITH THIS DETAIL.
10. FIRE SPRINKLER SYSTEMS SHOULD BE DESIGNED ACCORDING TO REDUCED PRESSURE WHEN USING A PRV IN THE VAULT.



ENOCH CITY
 900 E MIDVALLEY RD
 Enoch, UT 84721
 Tel. (435) 586-1119

**3" - 4" WATER METER
 (COMBINED CULINARY &
 FIRE SPRINKLER FLOWS)**

SCALE:
 N.T.S.
 DATE:
 DEC. 2022

DETAIL No.:

W5.4B

SHEET:
 2 of 2

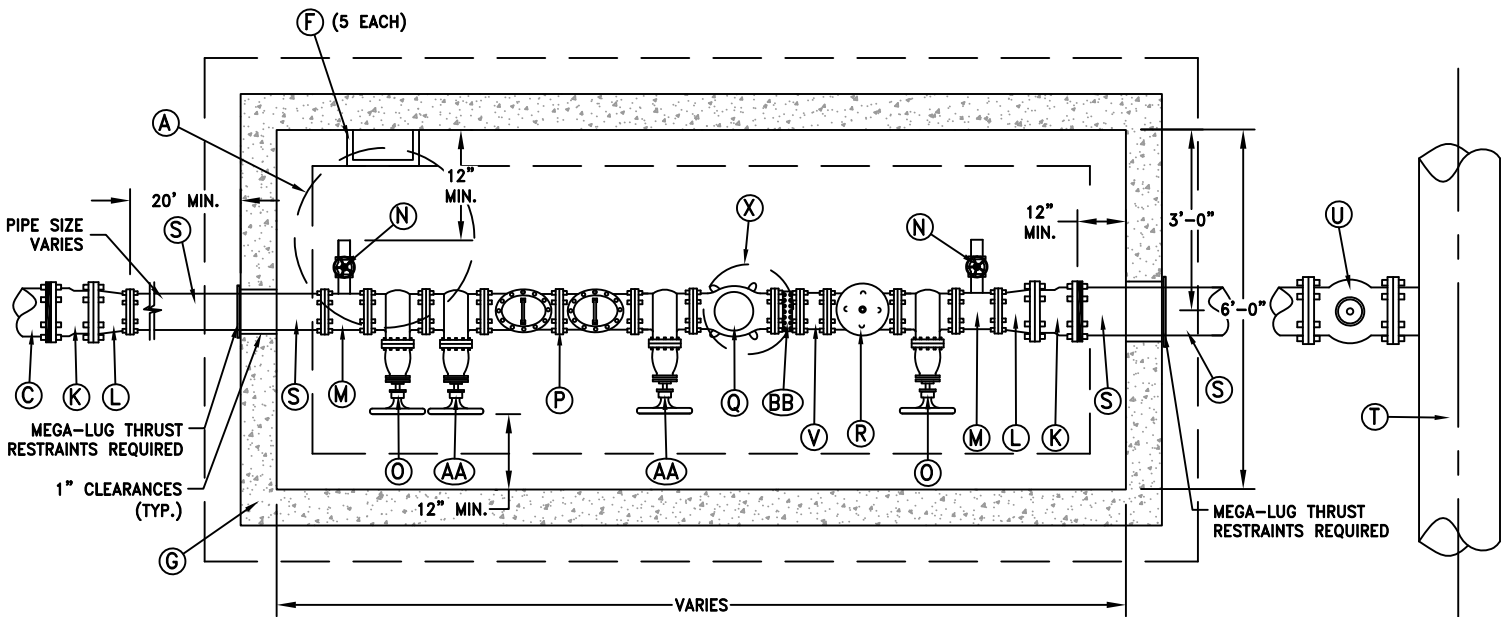

PLAN
N.T.S.

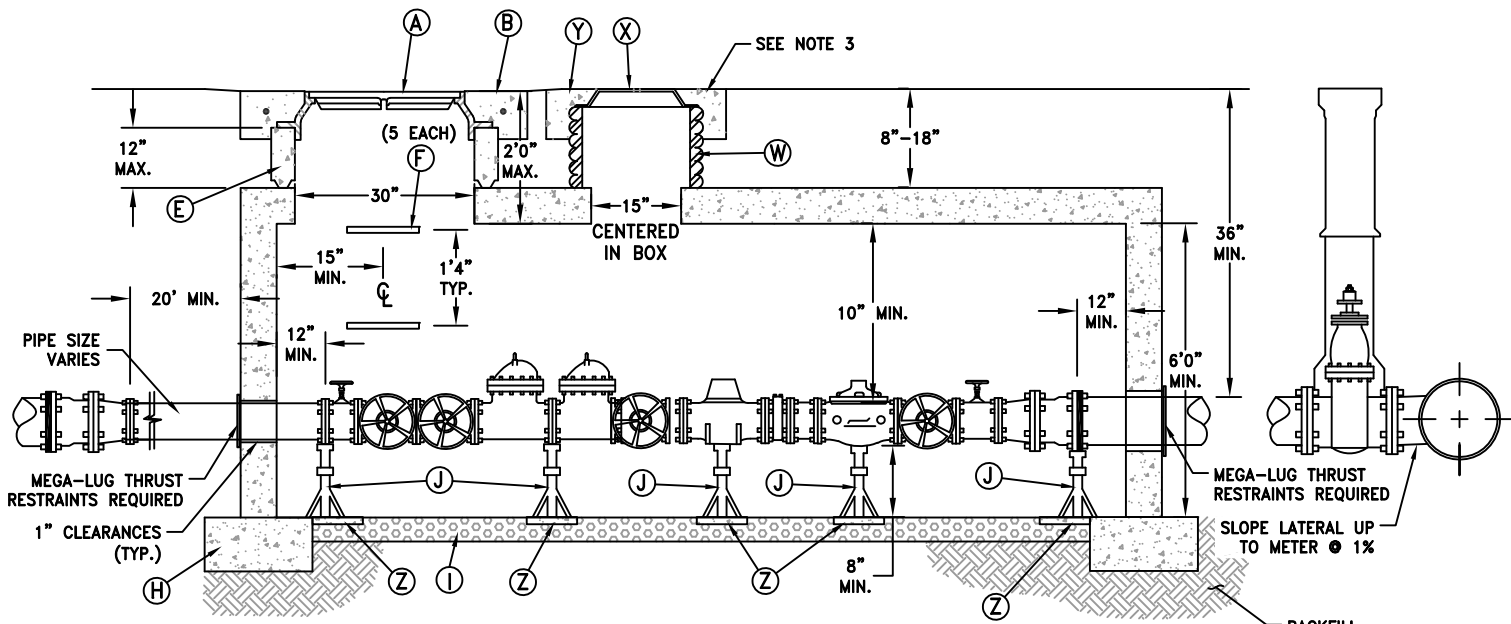

ELEVATION
N.T.S.

	<p>ENOCH CITY 900 E MIDVALLEY RD Enoch, UT 84721 Tel. (435) 586-1119</p>	<p>WATER METER w/ FIRE FLOW (COMBINED CULINARY & FIRE HYDRANT FLOWS)</p>	<p>SCALE: N.T.S. DATE: DEC. 2022</p>	<p>DETAIL No.: W6.0A SHEET: 1 of 2</p>
--	---	---	--	---

LEGEND

NO.	ITEM	DESCRIPTION
(A)	MANHOLE RING AND COVER (RIBLESS)	D&L A-1180 O.A.E.
(B)	4'0" SQUARE x 8" THICK CONCRETE COLLAR	w/ 40" SQUARE #4 BARS & FIBERS
(C)	PIPE MATERIAL PER PLUMBING CODE	
(D)	NOT USED	
(E)	GRADE RING(S)	MUST BE SEALED
(F)	MANHOLE STEP	(M.A. INDUSTRIES INC. O.A.E.)
(G)	CONCRETE VAULT TOP	AMCOR UV6127T O.A.E.
(H)	9"x18" FOOTING w/ (3) #4 BARS	
(I)	4" THICK DRAIN GRAVEL	
(J)	(2) LEVELING JACKS (LENGTH VARIES)	SLIDEWINDER PART #23535 BY BARKER MANUF. CO.
(K)	6" MIN. FLANGE ADAPTOR	CEMENT LINED
(L)	X"x6" FLANGED REDUCER (IF REQ'D)	CEMENT LINED
(M)	6" FLANGED STEEL SPOOL WITH 2" OUTLET	EPOXY COATED AND LINED
(N)	2" GATE VALVE WITH 4" NIPPLE	
(O)	6" GATE VALVE WITH HANDWHEEL	NON-RISING STEM
(P)	6" DOUBLE CHECK DETECTOR VALVE (DCDA)	AWWA APPROVED
(Q)	FLOW METER (PURCHASED FROM CITY)	
(R)	6" PRESSURE REDUCING VALVE (IF REQ'D)	AWWA APPROVED
(S)	6" MIN. D.I. PIPE	CEMENT LINED
(T)	CITY WATER MAIN	
(U)	GATE VALVE WITH BOX	SEE STANDARD DETAIL W1.0
(V)	6" FLANGED SPOOL 12" LONG	CEMENT LINED
(W)	18" DIA. HDPE PIPE	PER PIPE SPEC.
(X)	RING & LID w/ 2" PUNCHOUT	D&L-2241 O.A.E.
(Y)	30"x30"x8" THICK CONCRETE COLLAR	
(Z)	12"x12"x2" CONCRETE BLOCK	
(AA)	BACKFLOW ASSEMBLY VALVE	
(BB)	STRAINER (IF REQUIRED)	PURCHASED FROM CITY

NOTES:

- UNLESS OTHERWISE SHOWN ALL MATERIALS PER ENOCH CITY ENGINEERING STANDARDS.
- CONCRETE VAULT LENGTH & WIDTH SHALL BE SUFFICIENT TO CONTAIN ALL FITTINGS AND MAINTAIN INDICATED CLEARANCE FROM WALLS.
- WATER METER LIDS & COVERS SHALL ONLY BE INSTALLED IN LANDSCAPED AREAS UNLESS APPROVED BY WATER SUPERINTENDENT.
- NOT ALLOWED ON PRIVATE SYSTEMS WITH FIRE HYDRANTS.
- VAULTS ARE DESIGNED TO MEET ASTM C858 WITH AASHTO HS-20 LOADING.
- PRV IS REQUIRED FOR 80 PSI PRESSURE OR GREATER.
- STRAINER IS REQUIRED IF A PRV IS REQUIRED.
- ALL PIPE MATERIALS AND FITTINGS MUST BE RATED FOR WATER SYSTEM PRESSURE.
- ONLY NFPA 13R FIRE SPRINKLER SYSTEMS ARE ALLOWED WITH THIS DETAIL.
- FIRE SPRINKLER SYSTEMS SHOULD BE DESIGNED ACCORDING TO REDUCED PRESSURE WHEN USING A PRV IN THE VAULT.



ENOCH CITY
900 E MIDVALLEY RD
Enoch, UT 84721
Tel. (435) 586-1119

WATER METER w/ FIRE
FLOW (COMBINED CULINARY
& FIRE HYDRANT FLOWS)

SCALE:
N.T.S.
DATE:
DEC. 2022

DETAIL No.:

W6.0B

SHEET:
2 of 2

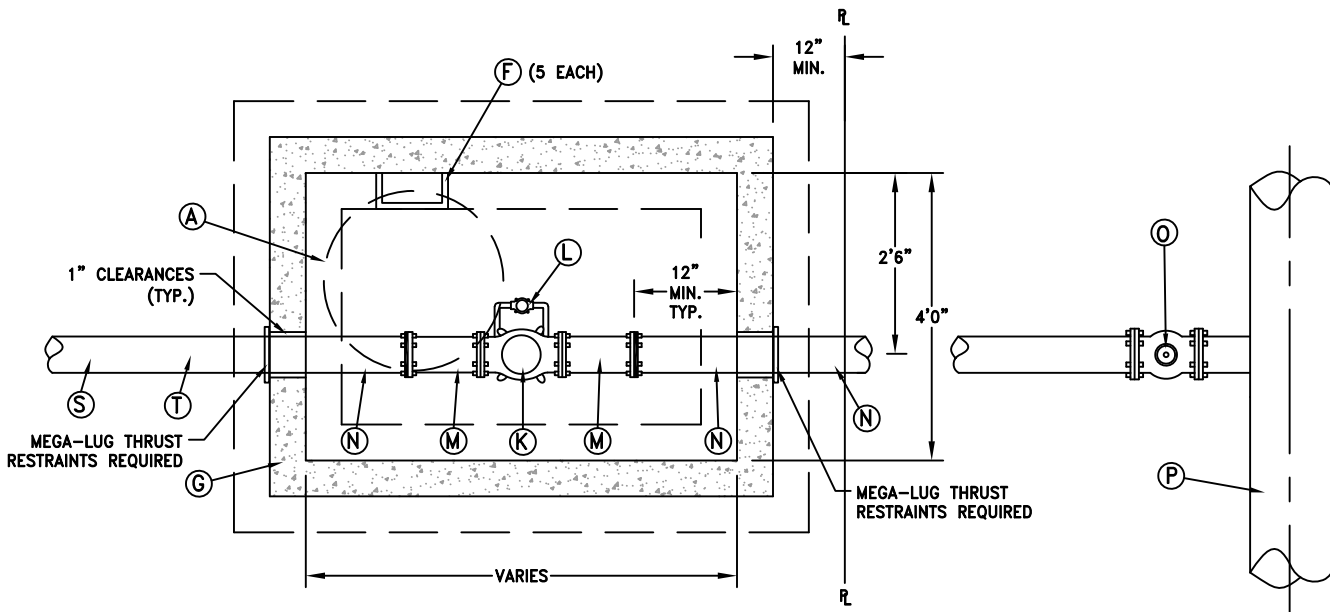

PLAN
N.T.S.

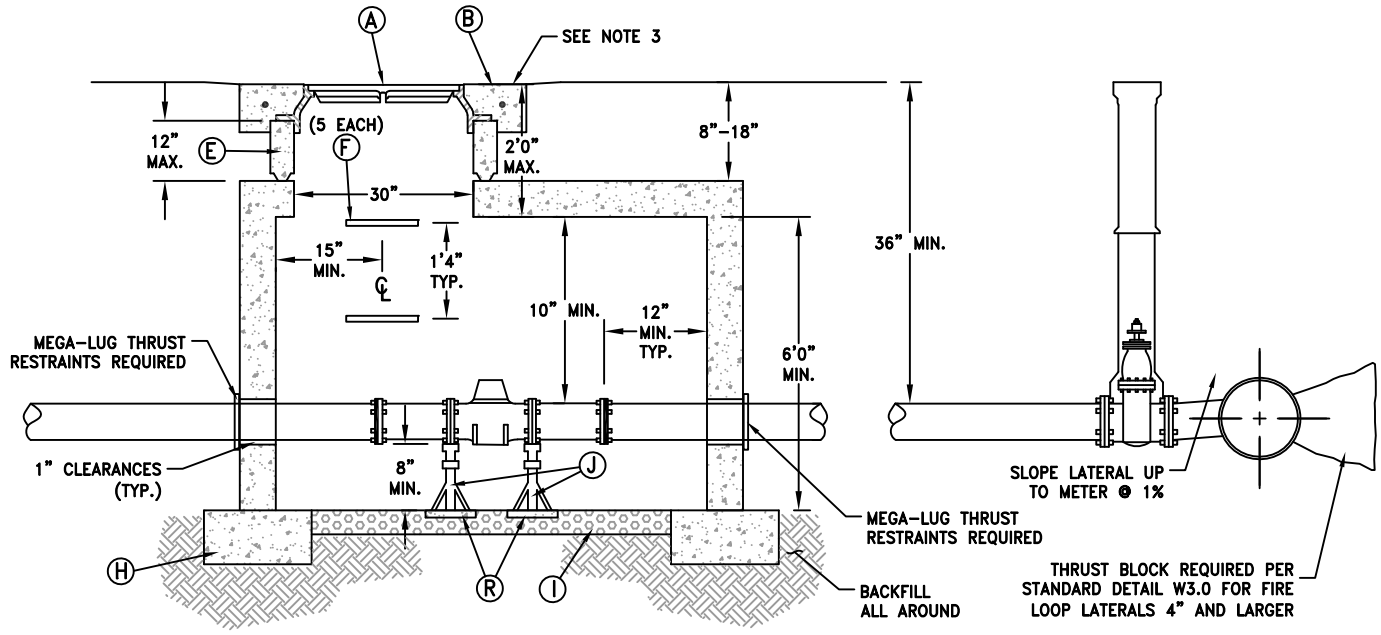

ELEVATION
N.T.S.



ENOCH CITY
900 E MIDVALLEY RD
Enoch, UT 84721
Tel. (435) 586-1119

**FIRE LOOP DETECTOR
CHECK VALVE
(FIRE FLOWS ONLY)**

SCALE:
N.T.S.
DATE:
DEC. 2022

DETAIL No.:

W7.0A

SHEET:
1 of 2

LEGEND

NO.	ITEM	DESCRIPTION
(A)	MANHOLE RING AND COVER (RIBLESS)	D&L A-1180 O.A.E.
(B)	4'0" SQUARE x 8" THICK CONCRETE COLLAR	w/ 40" SQUARE #4 BARS & FIBERS
(C)	NOT USED	
(D)	NOT USED	
(E)	GRADE RING(S)	MUST BE SEALED
(F)	MANHOLE STEP	(M.A. INDUSTRIES INC. O.A.E.)
(G)	CONCRETE VAULT TOP (4'0"x6'0")	AMCOR UV46T O.A.E.
(H)	9"x18" FOOTING w/ (3) #4 BARS	
(I)	4" THICK DRAIN GRAVEL	
(J)	(4) LEVELING JACKS (LENGTH VARIES)	SLIDEWINDER PART #23535 BY BARKER MANUF. CO.
(K)	SINGLE LEAK DETECTOR CHECK VALVE	WATTS SERIES SS07F O.A.E.
(L)	3/4" BY-PASS KIT	WITH METER AND VALVES
(M)	FLANGE ADAPTER	CEMENT LINED
(N)	DUCTILE IRON PIPE	CEMENT LINED
(O)	GATE VALVE WITH BOX	
(P)	CITY WATER MAIN	
(Q)	NOT USED	
(R)	12"x12"x2" CONCRETE BLOCK	
(S)	PIPE MATERIAL TO BUILDING PER PLUMBING CODE	
(T)	DUCTILE IRON PIPE (TO 10' OUTSIDE OF VAULT)	

NOTES:

1. UNLESS OTHERWISE SHOWN ALL MATERIALS PER ENOCH CITY ENGINEERING STANDARDS.
2. CONCRETE VAULT LENGTH & WIDTH SHALL BE SUFFICIENT TO CONTAIN ALL FITTINGS AND MAINTAIN INDICATED CLEARANCE FROM WALLS.
3. WATER METER LIDS & COVERS SHALL ONLY BE INSTALLED IN LANDSCAPED AREAS UNLESS APPROVED BY WATER SUPERINTENDENT.
4. VAULTS ARE DESIGNED TO MEET ASTM C858 WITH AASHTO HS-20 LOADING.
5. NO CULINARY WATER CONNECTION TO FIRE SPRINKLER SUPPLY LINES.
6. ALL PIPE MATERIALS AND FITTINGS MUST BE RATED FOR WATER SYSTEM PRESSURE.



ENOCH CITY
 900 E MIDVALLEY RD
 Enoch, UT 84721
 Tel. (435) 586-1119

FIRE LOOP DETECTOR CHECK VALVE (FIRE FLOWS ONLY)

SCALE:
 N.T.S.
 DATE:
 DEC. 2022

DETAIL No.:

W7.0B

SHEET:
 2 of 2

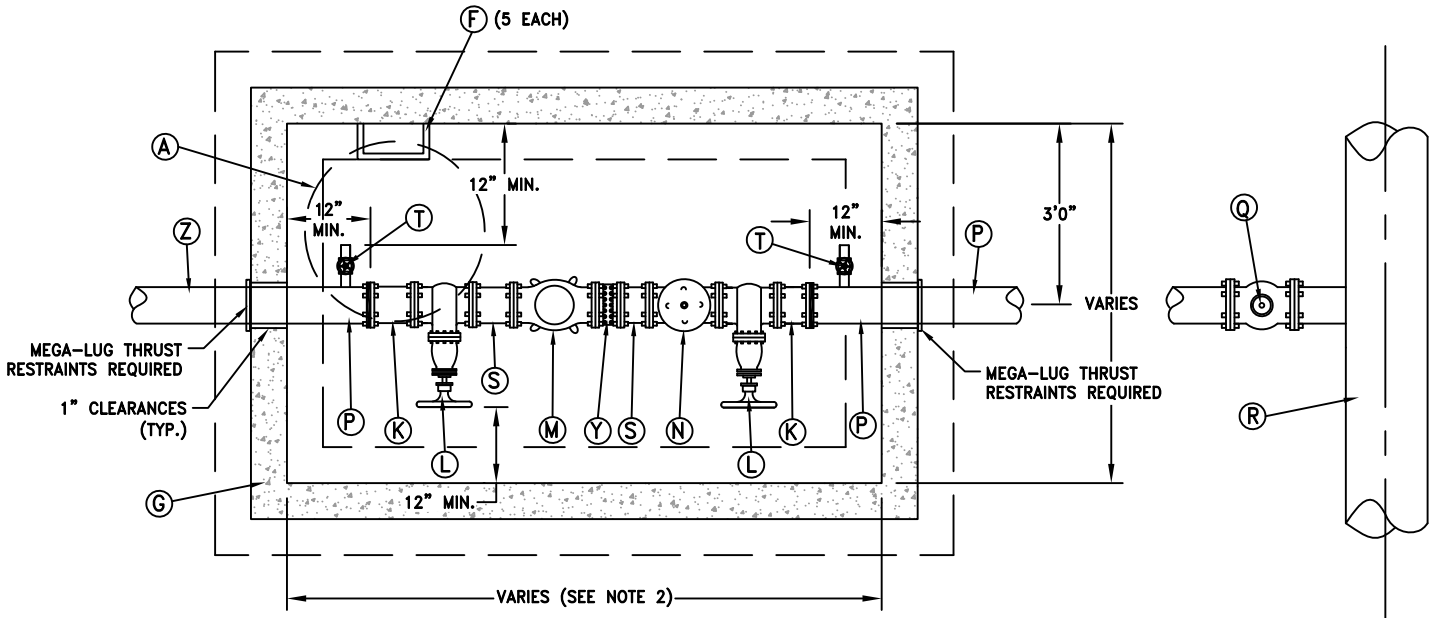

PLAN
N.T.S.

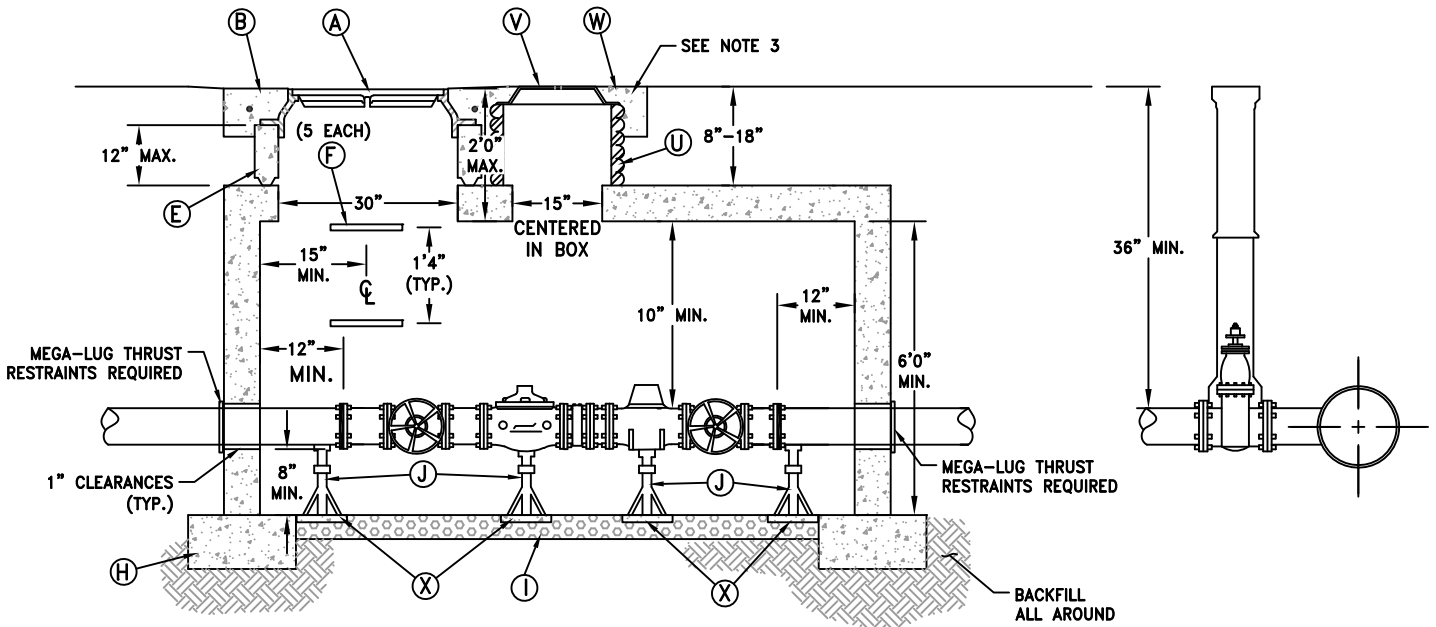

ELEVATION
N.T.S.



ENOCH CITY
900 E MIDVALLEY RD
Enoch, UT 84721
Tel. (435) 586-1119

IRRIGATION METER

SCALE:
N.T.S.
DATE:
DEC. 2022

DETAIL No.:

W8.0A

SHEET:
1 of 2

LEGEND

NO.	ITEM	DESCRIPTION
(A)	MANHOLE RING AND COVER (RIBLESS)	D&L A-1180 O.A.E.
(B)	4'0" SQUARE x 8" THICK CONCRETE COLLAR	w/ 40" SQUARE #4 BARS & FIBERS
(C)	NOT USED	
(D)	NOT USED	
(E)	GRADE RING(S)	MUST BE SEALED
(F)	MANHOLE STEP	(M.A. INDUSTRIES INC. O.A.E.)
(G)	CONCRETE VAULT TOP	AMCOR or APPROVED EQUAL
(H)	9"x18" FOOTING w/ (3) #4 BARS	
(I)	4" THICK DRAIN GRAVEL	
(J)	(4) LEVELING JACKS (LENGTH VARIES)	SLIDEWINDER PART #23535 BY BARKER MANUF. CO.
(K)	FLANGE ADAPTOR	CEMENT LINED
(L)	GATE VALVE WITH HANDWHEEL	NON-RISING STEM
(M)	FLOW METER (PURCHASED FROM CITY)	MACH 10
(N)	PRESSURE REDUCING VALVE (IF REQ'D)	
(O)	NOT USED	
(P)	DUCTILE IRON PIPE (TO 10' OUTSIDE OF VAULT)	CEMENT LINED
(Q)	GATE VALVE WITH BOX	SEE STANDARD DETAIL W1.0
(R)	IRRIGATION MAIN	
(S)	FLANGED SPOOL 12" LONG	
(T)	PIPE TAP (SIZE VARIES) w/ GATE VALVE & 4" NIPPLE	
(U)	18" DIA. HDPE PIPE	PER PIPE SPEC.
(V)	RING & LID w/ 2" PUNCHOUT	D&L-2241 O.A.E.
(W)	30"x30"x8" THICK CONCRETE COLLAR	
(X)	12"x12"x2" CONCRETE BLOCK	
(Y)	STRAINER (IF REQUIRED)	PURCHASED FROM CITY
(Z)	DUCTILE IRON PIPE (TO 10' OUTSIDE OF VAULT)	

NOTES:

- UNLESS OTHERWISE SHOWN ALL MATERIALS PER ENOCH CITY ENGINEERING STANDARDS.
- CONCRETE VAULT LENGTH & WIDTH SHALL BE SUFFICIENT TO CONTAIN ALL FITTINGS AND MAINTAIN INDICATED CLEARANCE FROM WALLS.
- WATER METER LIDS & COVERS SHALL ONLY BE INSTALLED IN LANDSCAPED AREAS UNLESS APPROVED BY WATER SUPERINTENDENT.
- VAULTS ARE DESIGNED TO MEET ASTM C858 WITH AASHTO HS-20 LOADING.
- PRV IS REQUIRED FOR 80 PSI PRESSURE OR GREATER.
- STRAINER IS REQUIRED IF A PRV IS REQUIRED.
- ALL PIPE MATERIALS AND FITTINGS MUST BE RATED FOR WATER SYSTEM PRESSURE.



ENOCH CITY
900 E MIDVALLEY RD
Enoch, UT 84721
Tel. (435) 586-1119

IRRIGATION METER

SCALE:
N.T.S.
DATE:
DEC. 2022

DETAIL No.:

W8.0B

SHEET:
2 of 2

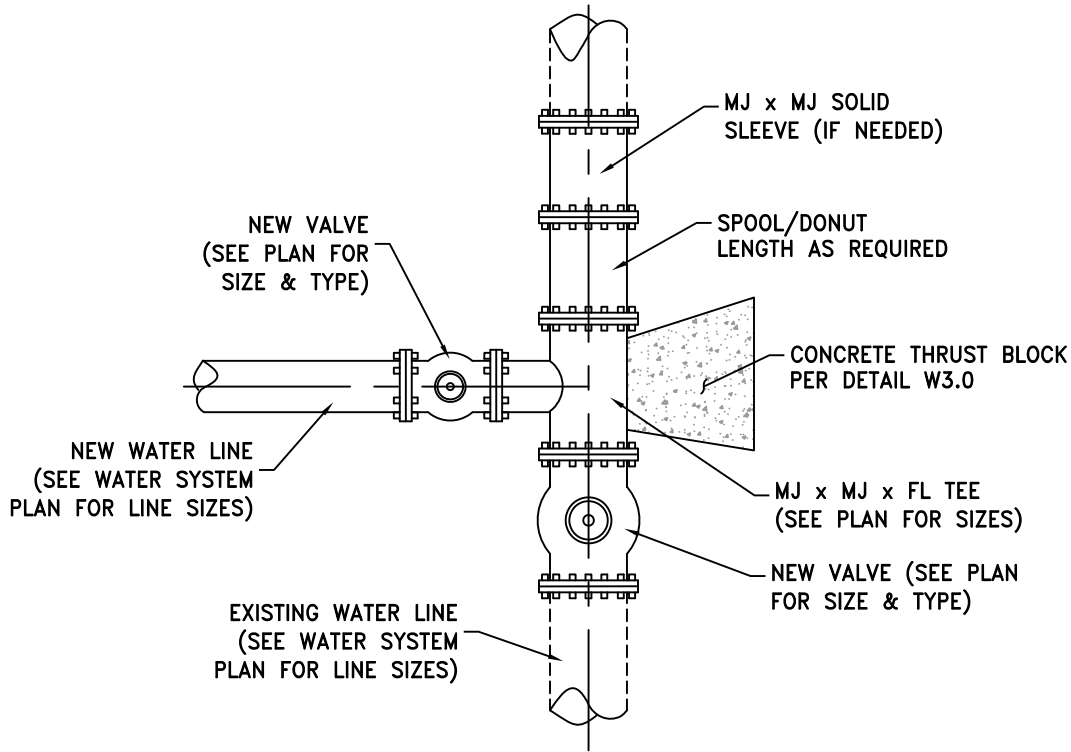

CUT-IN TEE CONNECTION

N.T.S.

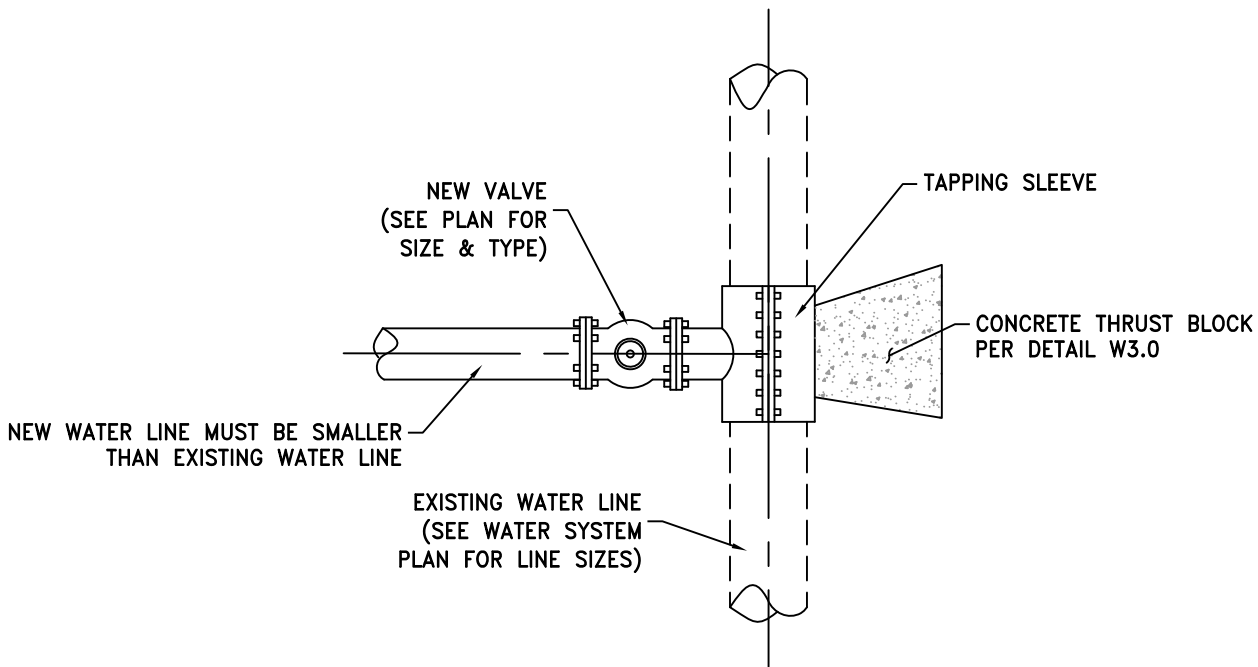

TAPPED CONNECTION

N.T.S.

NOTES:

- MECHANICAL JOINTS AT ALL FITTINGS SHALL BE WRAPPED WITH TWO LAYERS OF 6mm POLYETHYLENE SO THAT ALL BOLTS, NUTS & CONNECTIONS ARE COVERED. POLYETHYLENE TO BE PULLED UP OVER BONNET OF VALVE TO COVER BOLTS. DUCT TAPE or WIRE TO BE USED TO SECURE PLASTIC WRAPPING IN PLACE.



ENOCH CITY
900 E MIDVALLEY RD
Enoch, UT 84721
Tel. (435) 586-1119

**WATER MAIN TO
MAIN CONNECTION**

SCALE:
N.T.S.
DATE:
DEC. 2022

DETAIL No.:

W9.0

SHEET:
1 of 1

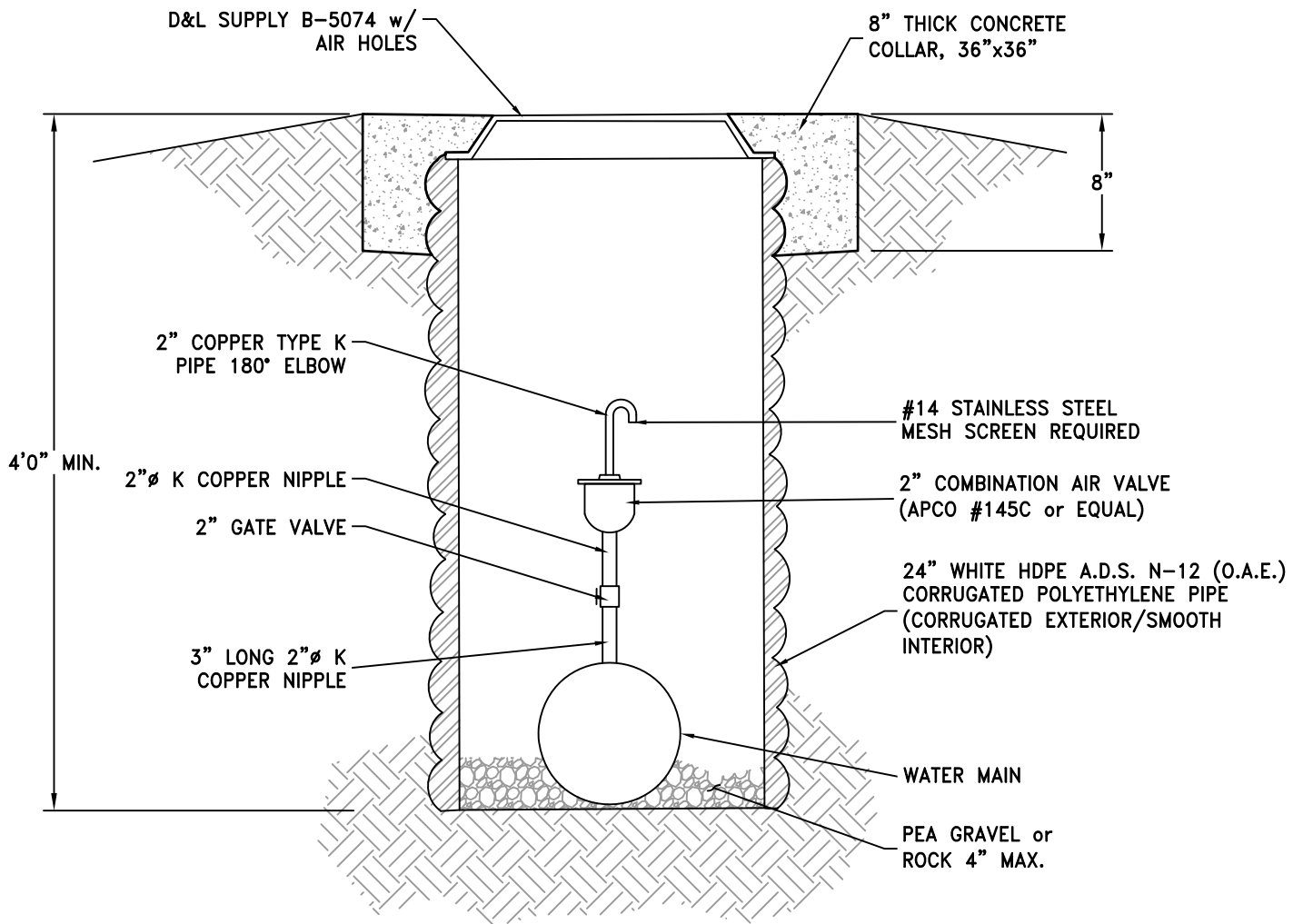

COMBINATION AIR VALVE DETAIL OUTSIDE ROADWAY

N.T.S.

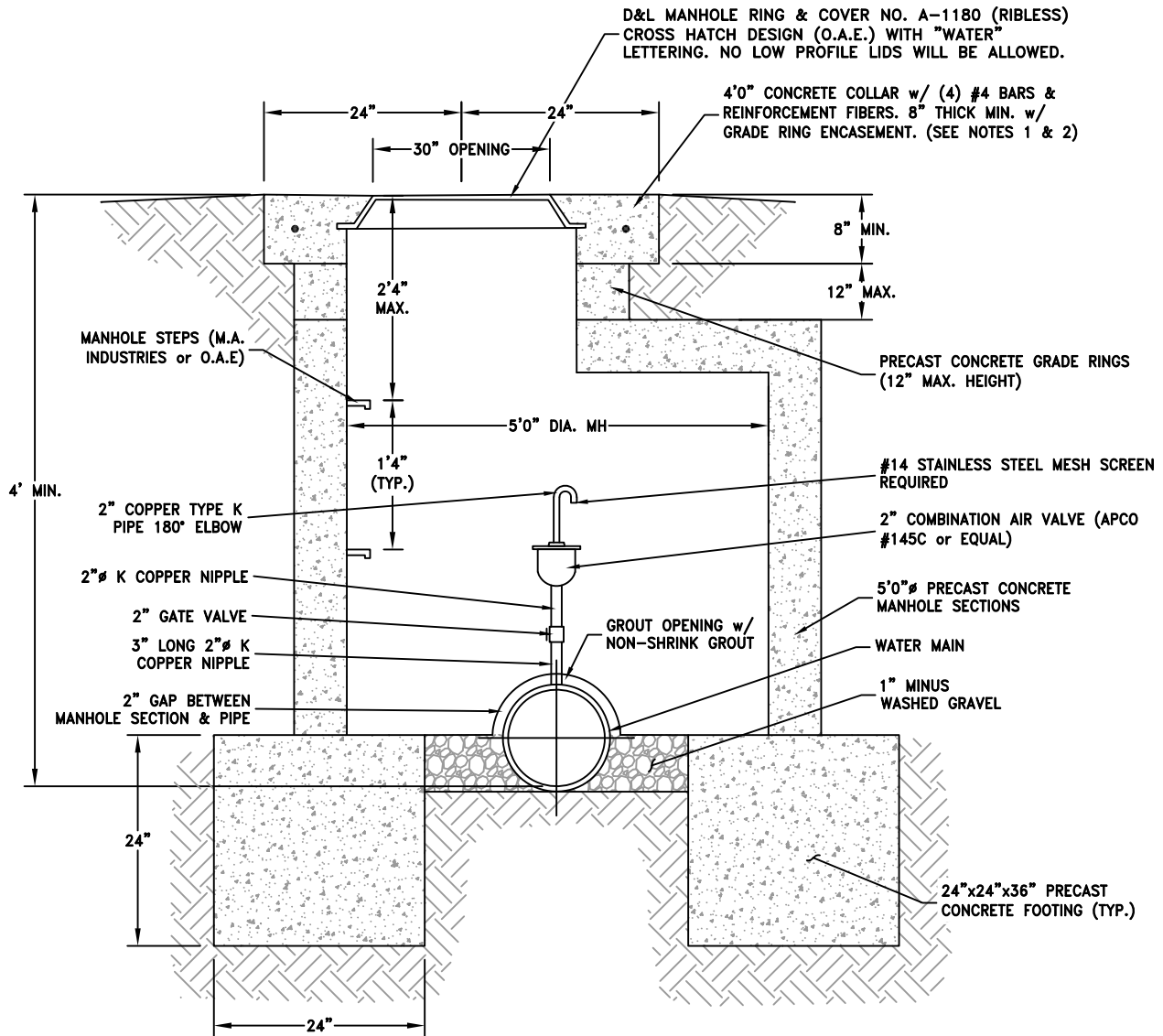

COMBINATION AIR VALVE DETAIL IN ROADWAY

N.T.S.

NOTES:

1. MANHOLES IN ROADWAYS REQUIRE CONCRETE COLLAR. IN UNIMPROVED AREAS, THE TOP OF LID SHALL BE SET 6" TO 12" ABOVE FINISH GRADE (NO CONCRETE COLLAR REQUIRED).
2. MANHOLE LID, RING, AND CONCRETE COLLAR TO BE CENTERED ON MANHOLE OPENING AND SET ¼" BELOW TOP OF ASPHALT.
3. MANHOLE VAULT MUST BE DESIGNED TO MEET AASHTO HS-20 LOADING.



ENOCH CITY
900 E MIDVALLEY RD
Enoch, UT 84721
Tel. (435) 586-1119

COMBINATION AIR
VALVE DETAIL IN
ROADWAY

SCALE:
N.T.S.
DATE:
DEC. 2022

DETAIL No.:

W10.2

SHEET:
1 of 1

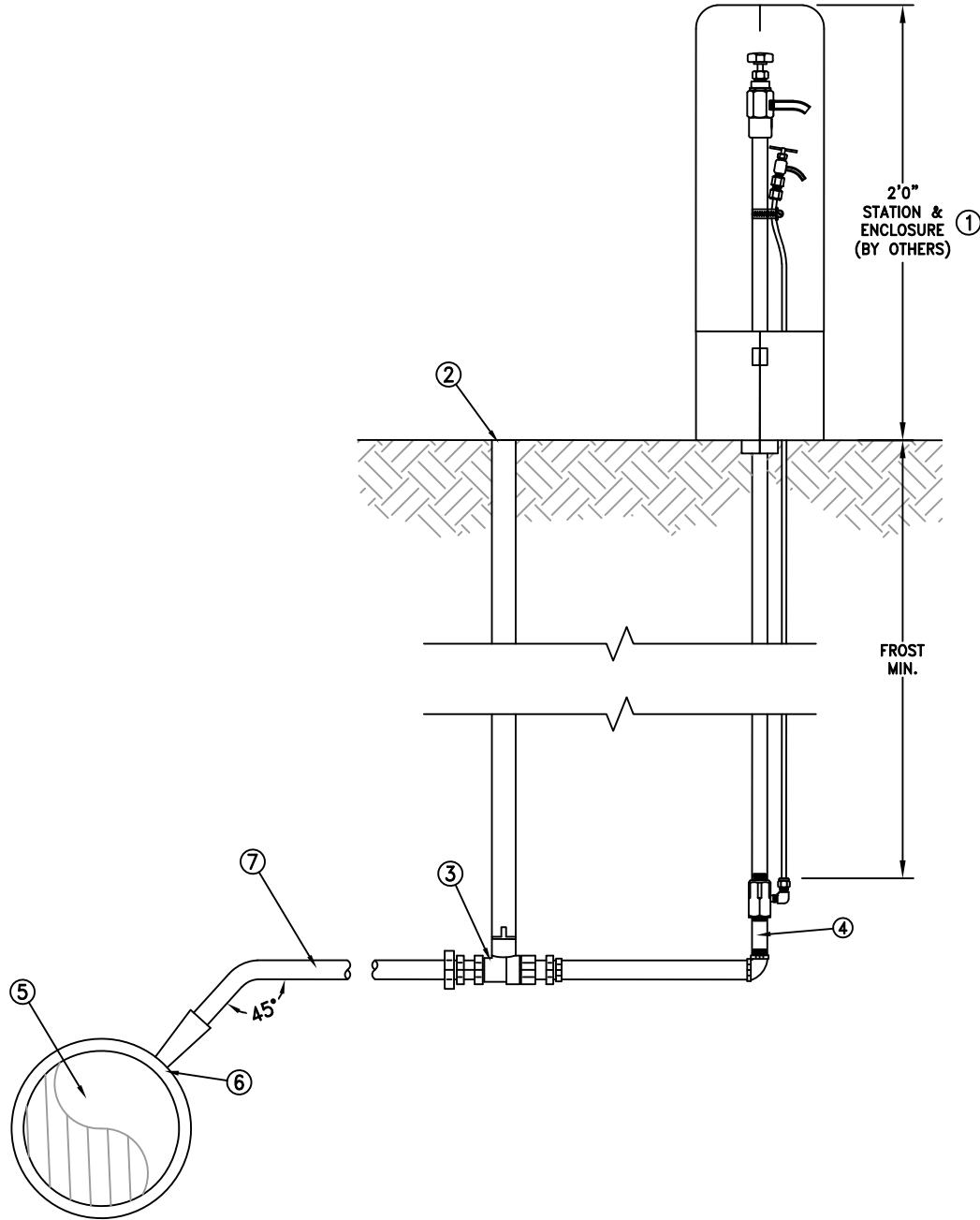

NOTES:

1. STATION SHALL BE MODEL #88-SS AS MANUFACTURED BY KUPFERLE FOUNDRY, ST. LOUIS, MO, 63102 or APPROVED EQUAL.
2. WHEN INSTALLED ON A CONCRETE SLAB FOLLOW MANUFACTURER'S GUIDELINES AND SPECS.
3. WHEN INSTALLED IN CORROSIVE SOILS, FOLLOW MANUFACTURER'S GUIDELINES AND SPECS TO PROTECT THE PIPE & FITTINGS.
4. SAMPLING STATION TO BE LOCATED AT THE MIDDLE OF SUBDIVISION or AT THE PROPERTY LINE.

ITEM	ITEM / DESCRIPTION
1	#88-SS SAMPLING STATION
2	CURB STOP VALVE BOX
3	1" CURB STOP BALL VALVE
4	3/4" S.S. NIPPLE
5	WATER MAIN
6	STAINLESS STEEL SADDLE CLAMP
7	1" PVC (TUFF TUBE) SERVICE PIPE



ENOCH CITY
 900 E MIDVALLEY RD
 Enoch, UT 84721
 Tel. (435) 586-1119

WATER SAMPLING
 STATION

SCALE:
 N.T.S.
 DATE:
 DEC. 2022

DETAIL No.:

W11.0

SHEET:
 1 of 1